

### Components and Hardware List

Table Top

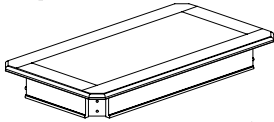

(A)

1 pc.

Bottom Shelf

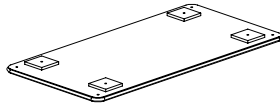

(B)

1 pc.

Post



(C)

4 pcs.

Base Foot



(D)

4 pcs.

Castor



(E)

4 pcs.

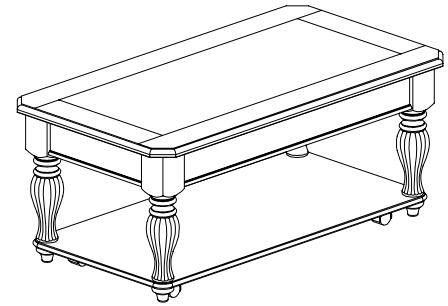

#32504 & #32404  
LIFT-TOP RECTANGULAR COCKTAIL TABLE

M<sup>5</sup>/<sub>16</sub>" x 2<sup>1</sup>/<sub>4</sub>" Hex-Head Bolt

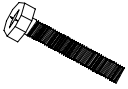

(F)

8 pcs.

M<sup>5</sup>/<sub>16</sub>" Flat Washer



(G)

12 pcs.

M<sup>5</sup>/<sub>16</sub>" Spring Washer



(H)

8 pcs.

12mm Wrench

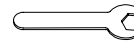

(I)

1 pc.

Be sure to check all packing material carefully for small parts, which may have come loose inside the carton during shipment.

#### ASSEMBLY STEPS:

- Carefully place the Table Top upside down on a clean, soft surface such as a blanket or carpet.
- Place a Post in the corner of the Table Top and attach with two Hex-Head Bolts (F), Spring Washers (H) and Flat Washers (G) each. Tighten with the Wrench (I).
- Attach the Bottom Shelf to the bottom of the Posts using the Base Foot (D), tightened hand tight.
- If desired, attach the Casters (E) to the bottom of the Bottom Shelf (B). Tighten with the Wrench (I).

Carefully set the assembled table upright.

To prevent possible damage to some types of flooring, never roll casters on unprotected hardwood or vinyl flooring.

#### CAUTION!

DO NOT ALLOW CHILDREN TO PLAY ON THE MECHANIZED FURNITURE OR OPERATE THE MECHANISM. TOP SURFACES FOLD DOWN ON CLOSING, SO THAT A CHILD COULD POSSIBLY BE INJURED. ALWAYS LEAVE FURNITURE IN THE CLOSED POSITION WHEN UNATTENDED. TO PREVENT THE TABLE FROM TIPPING OVER, DO NOT PLACE MORE THAN 30 POUNDS ON THE TOP WHEN IN THE OPEN POSITION.

KEEP HANDS CLEAR OF MECHANISM.

Step 1 & 2

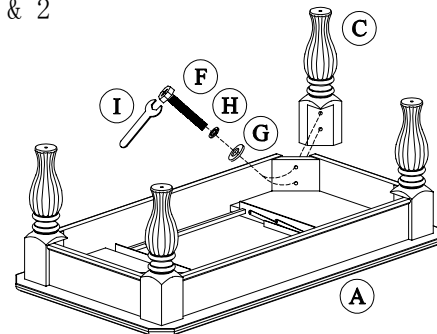

The Lift-Top is secured for shipping. Do not release until table has been completely assembled and setting upright.

Step 3 & 4

