

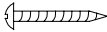

Components and Hardware List

Key	1/2" Wood Screw	File rod	Bun Foot W/ Leveler
			
(A) 2 set.	(B) 8 pcs.	(C) 4 pcs.	(D) 4 pcs.

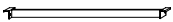

**44735
File Cabinet**

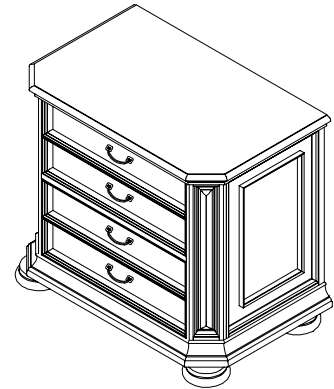
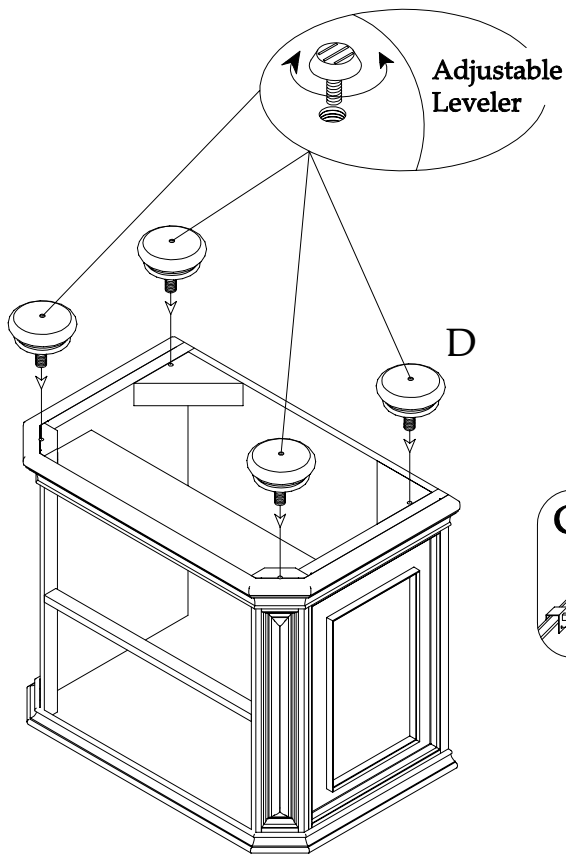

There are levelers located underneath the front corners which can be adjusted to compensate for uneven flooring if necessary. To adjust, tilt the top of the cabinet back towards the wall, while carefully reaching underneath cabinet and adjusting levelers as needed.

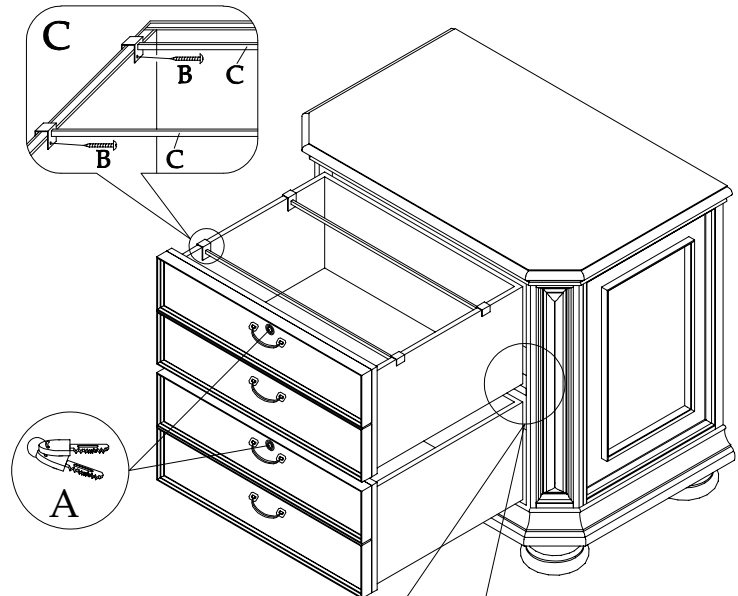

This furniture is equipped with safety hardware to prevent both drawers from being opened at the same time, to prevent the cabinet from tipping forward. Please do not try to override this feature and completely close one drawer before opening the other.

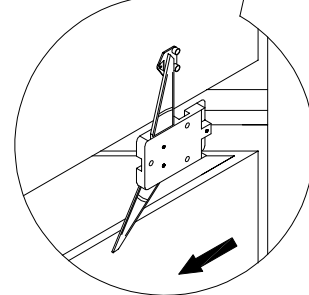

Each drawer may be set-up to accept hanging file folders in the various configurations shown. The wood screws provided can be used to attach the file bars to the drawer sides to help keep the files from shifting in the drawers.

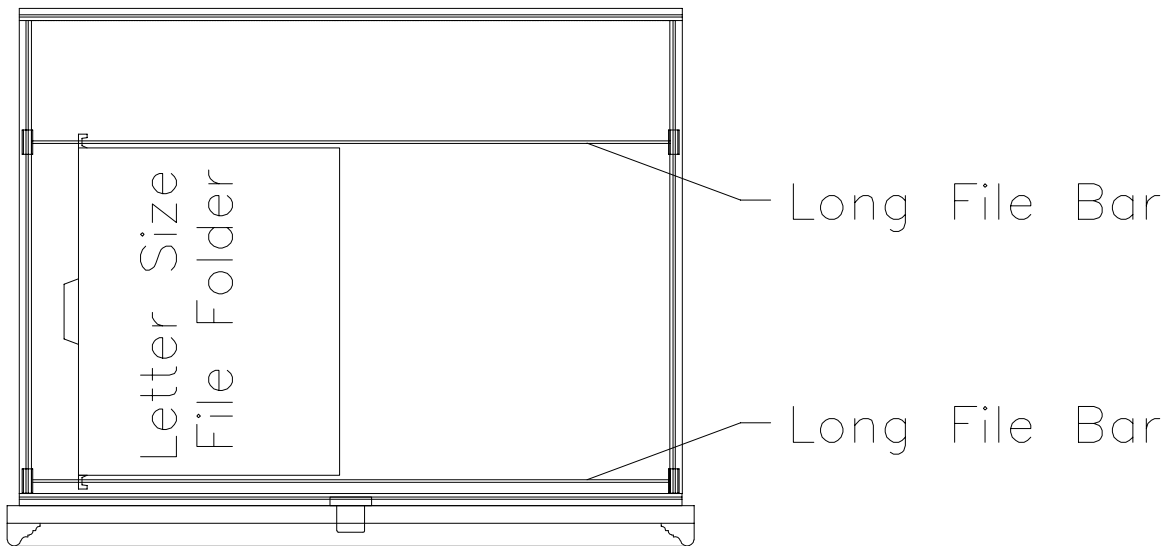
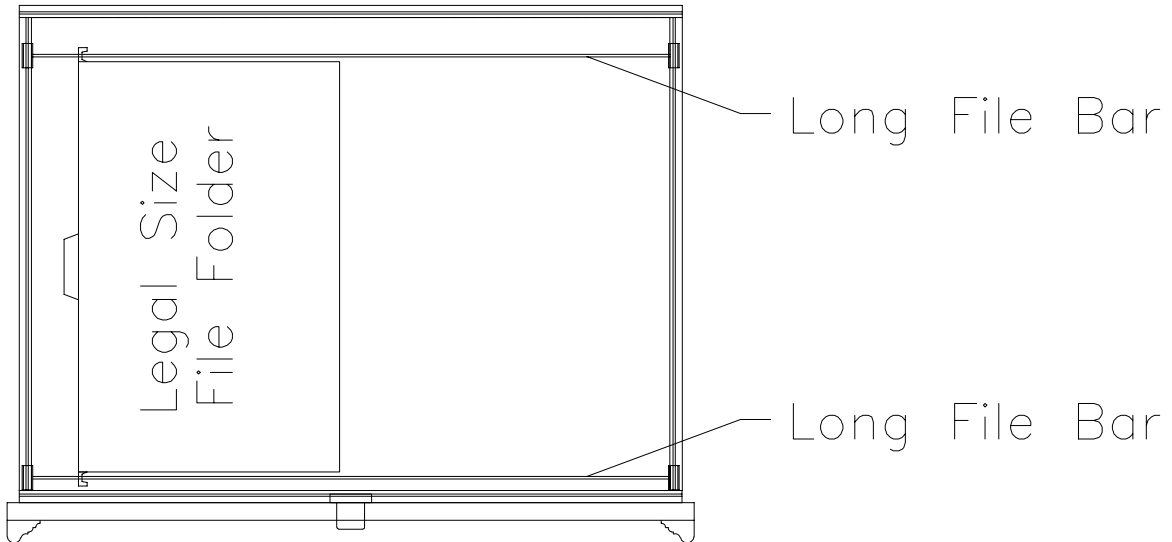

File Cabinet Set-up

This file cabinet has safety hardware installed to prevent both drawers from being opened at the same time, which minimizes the risk of the file cabinet accidentally tipping forward, possibly causing damage or personal injury. To properly set-up and use this file cabinet there are a few things that must be checked or steps performed before loading drawers with files and using. It is imperative that a file cabinet be level for the drawers and anti-tip interlock system to work properly. Please read this entire document before loading files into drawers. After the file cabinet has been set-up and being used, if it becomes necessary to move the file cabinet to another location, to prevent excessive stress on the cabinet, all files must be removed from the drawers and the drawers locked, if so equipped.

NEVER ATTEMPT TO OPEN BOTH DRAWERS AT THE SAME TIME BECAUSE DAMAGE TO THE FILE CABINET OR DRAWER INTERLOCK MECHANISM CAN OCCUR AND CAUSE THE FILE CABINET TO BE UNSAFE. THE DRAWERS MUST BE FULLY CLOSED FOR THE ANTI-TIP MECHANISM TO BE IN A 'NEUTRAL' POSITION AND ALLOW EITHER DRAWER TO BE OPENED. SOME FILE CABINET MODELS ARE EQUIPPED WITH KEY-LOCKS. IF NEITHER DRAWER WILL OPEN EASILY, MAKE SURE THE DRAWERS ARE NOT KEY-LOCKED.

Leveling

All Riverside Furniture Corp. lateral file cabinets are equipped with levelers underneath the front corners which can be adjusted enough to level most cabinets. When we refer to 'level' we are not necessarily meaning exactly 'level to the world', but level within limits to allow proper function of the drawers. The preferred tool to use would be a small bubble-type level if available, or for an acceptable alternative see below. Various floor coverings also have differing effects on set-up and long-term operation. For instance, if the file cabinet is placed on carpet, the carpet probably has a tack strip underneath at the edge next to a wall, which will raise the back of the file cabinet, which can cause the drawers to automatically try to open. This must be corrected with the levelers under the front of the cabinet.

After moving the file cabinet to its final location in the room, check to see if the file cabinet is level. Place the level left-to-right along the front edge of the cabinet. Very few floors will be out-of-level enough in this direction to cause problems, but if necessary, tilt the file cabinet back slightly and locate the levelers underneath the front corners and adjust as necessary. Place the level on the top, near the middle of the cabinet, going front-to-back. Now, the front of the cabinet must actually be slightly out-of-level, approximately 1/8" to 1/4" higher in the front than the back of the cabinet, to help hold the drawers shut when closed.

If a bubble level is not available, a suitable alternative is to use a round pen or pencil. Place the pencil pointed front-to-back on the cabinet top. Push the pencil slightly one direction and then the other. The pencil should not continue to roll left-to-right across the cabinet. Place the pencil along the front edge, pushing the pencil slightly, it should continue to roll slowly towards the back of the cabinet. The cabinet is now properly leveled.

Drawer Anti-Tip Inter-lock Mechanism

The drawer interlock mechanism / wedge blocks have been carefully installed at the factory for proper operation. The mechanism is activated by the black plastic wedge block attached to the side of the drawer. When either drawer is opened, the wedge block pulls the corresponding arm of the mechanism forward, locking the other arm and preventing the other drawer from opening. When the drawer is closed, the wedge block pushes the arm back, allowing either drawer to be opened. The position of all three components relative to each other is critical and must not be modified except by an experienced furniture repair technician if they fail to function properly. In the rare event any of the parts become misaligned and both drawers can be opened at the same time, use extreme care until a repair technician can correct the problem.

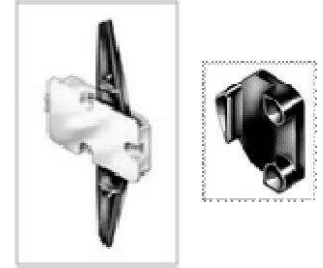

Drawer Removal

If a drawer is removed, it must be reinstalled back into the same opening for the anti-tip drawer interlock mechanism to function properly.

When either drawer is pulled open, the wedge block attached on the side of that drawer moves the arm of the snapper forward, locking the arm for the other drawer, thereby preventing the other drawer from being opened. If both drawers must be removed, after pulling the first drawer open and removing, the arm of the snapper that was pulled forward by the first drawer must be pushed back to the upright position, which will unlock the arm for the second drawer and allow it to be removed also.

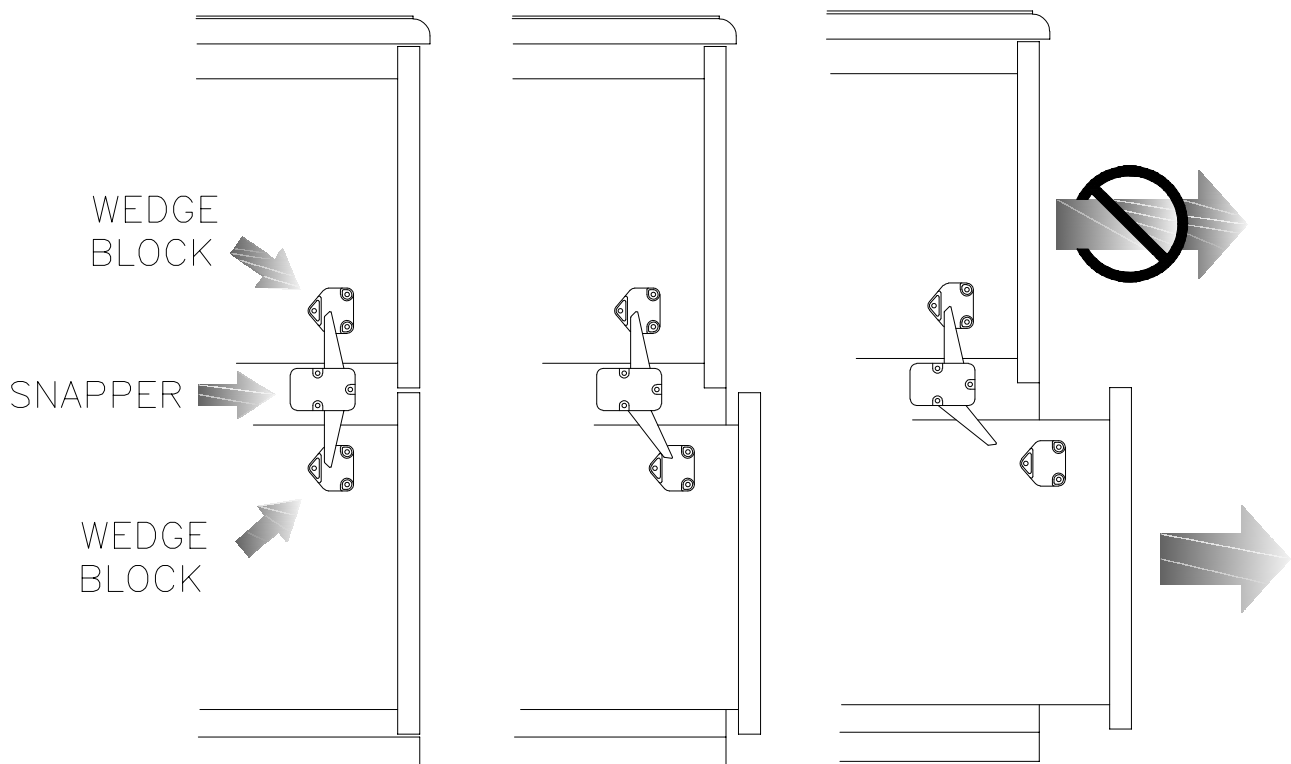

Steps For Removing Drawers Equipped With Ball-Bearing Side Guides.

Drawer Removal (cont.) All file drawers will be equipped with one of the two guide types depicted below.

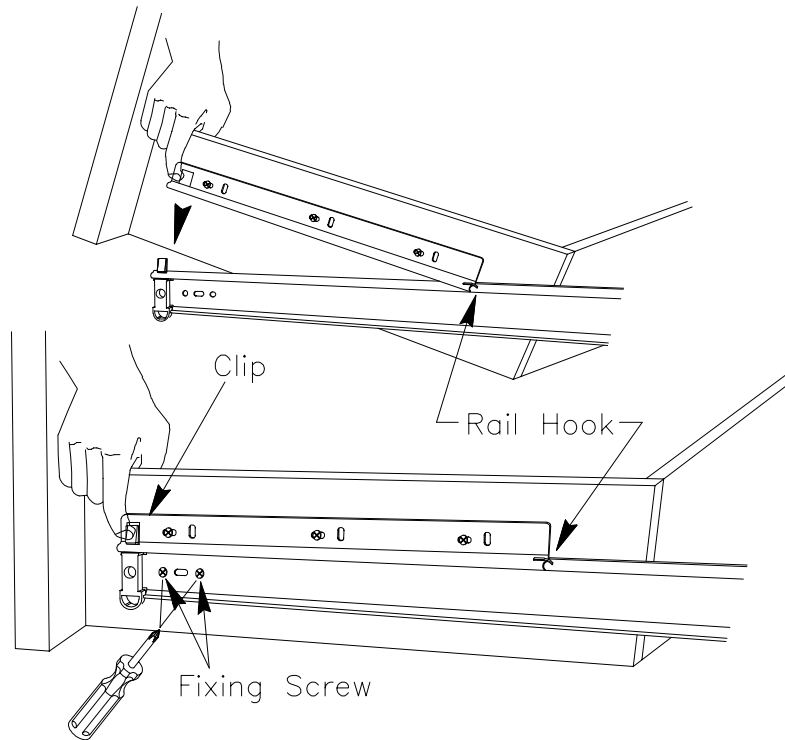

To Remove Drawer

- Pull the drawer fully open (remove the fixing screws if required).
- Simultaneously push the black plastic clip on both rails "in" and hold in place.
- At the same time, lift the drawer and pull forward to disengage the rail from the slide.

To Reinstall Drawer:

- Engage rail with the hook at the end of the slide.
- Lower drawer and allow the clip to pass through the opening in the rail.
- A "click" will be heard as the clip locks.
- Replace fixing screw if required.

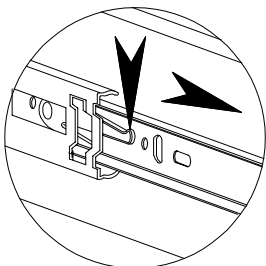

To release
drawer slide

To remove drawer:

- Pull the drawer fully open so the black latch is visible in the inside channel of the guides.
- Release the latches by simultaneously pushing one lever up and the other down.
- At the same time, pulling the drawer forward until the slides release. If necessary, empty drawer before removing.

To Reinstall Drawer:

- Carefully reinstall the drawer by aligning the channels on the drawer with the ball bearings in the channels of the cabinet members and gently pushing the drawer closed.
- Carefully open the drawer to verify it is working properly.