

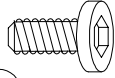







Components and Hardware List

<p>M5/16" X 3/4" Allen Head Bolt</p>  <p>A 12 pcs.</p>	<p>5/16" Spring Washer</p>  <p>B 12 pcs.</p>	<p>5/16" x 18mm Flat Washer</p>  <p>C 12 pcs.</p>	<p>5mm Allen Wrench</p>  <p>D 1 pc.</p>
<p>M5/32" x 3/4" Hardware Screw</p>  <p>E 2 pcs.</p>	<p>Drawer Pull</p>  <p>F 1 pc.</p>	<p>Top</p>  <p>G 1 pc.</p>	<p>Middle Shelf</p>  <p>H 1 pc.</p>
<p>Cabinet Box</p>  <p>I 1 pc.</p>	<p>Front Leg Assembly</p>  <p>J 1 pc.</p>	<p>Back Leg Assembly</p>  <p>K 1 pc.</p>	

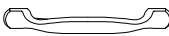
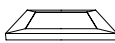

5610 Chairside Table

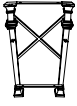
Be sure to check all packing material carefully for small parts, which may have come loose inside the carton during shipment.

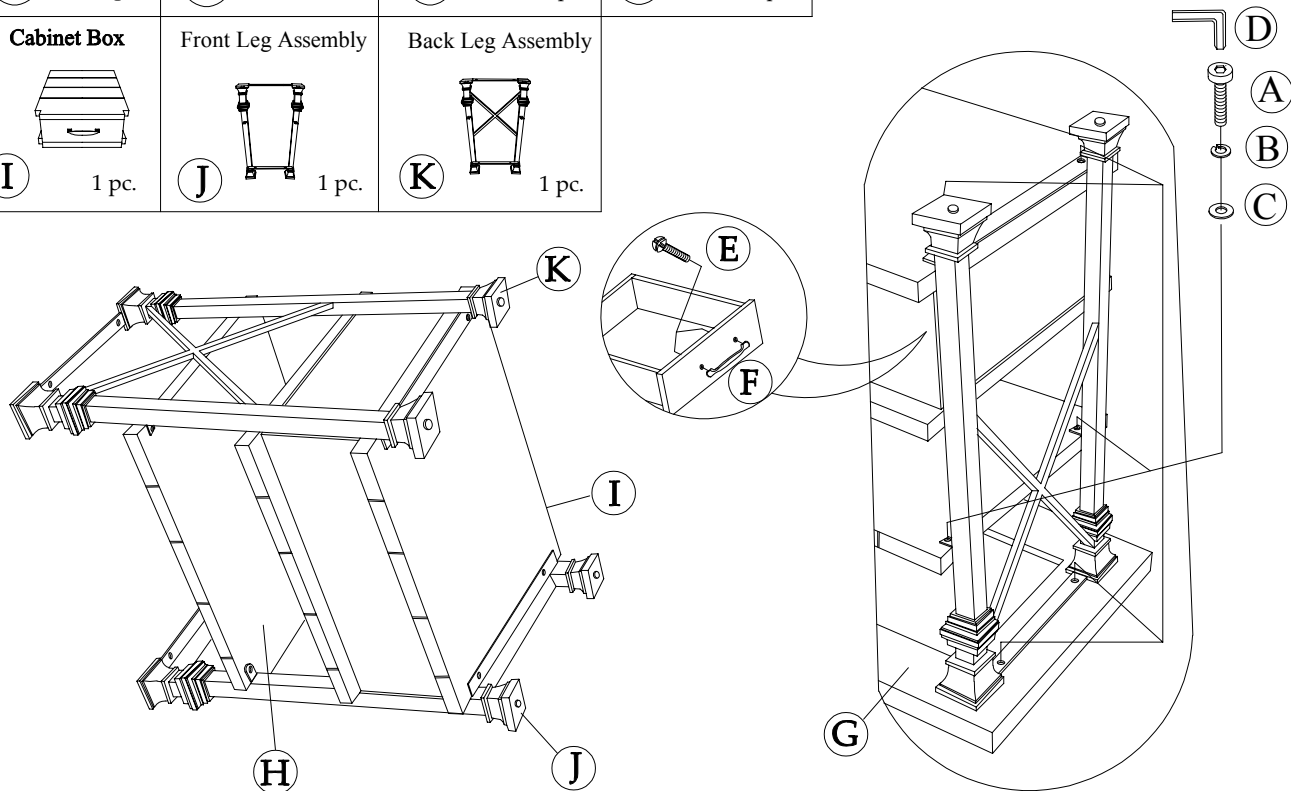

1. Do not discard any packing materials until the table has been completely assembled, to prevent parts from being accidentally discarded. To prevent possible scratches or damages, assemble the Table on a soft surface such as a blanket or carpet, or it's own packaging materials.
2. Position the Front Leg Assembly (H) (or Back Leg Assembly) face down.
3. Attach the Middle Shelf (F) and Cabinet Box (G) to the tabs on the Front (or Back) Leg Assembly using the Flat Washers (C), Spring Washers (B), and Allen Head Bolts (A). Do not fully tighten Bolts until the entire table has been assembled.
4. Position the remaining Leg Assembly onto the edge of the Shelf and Cabinet Box and attach using the same Flat Washers (C), Spring Washers (B), and Allen Head Bolts (A) as in previous step. Do not fully tighten Bolts.
5. Place the Top (E) upside down. Carefully place the assembled Table onto the table Top. Attach the assembled Table to the Top using the same Bolts and Washers as Before.
6. Tighten all the Bolts using the Allen Wrench (D).
7. Carefully set the assembled Table upright.
8. Attach the Drawer Pull (F) using the Hardware Screws (E) and tighten using your Phillips Screwdriver.
9. Levelers are installed into the bottom of the Leg Assemblies and can be used to compensate for uneven flooring if necessary.