

Components and Hardware List

M5/16" X 3/4" Allen Head Bolt

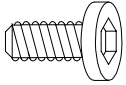

A 12 pcs.

5/16" Spring Washer



B 12 pcs.

5/16" x 18mm Flat Washer



C 12 pcs.

5mm Allen Wrench



D 1 pc.

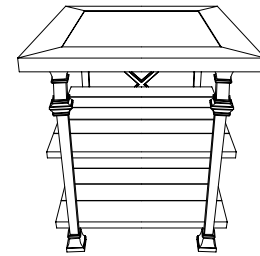

5609 End Table

Top

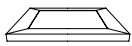

E 1 pc.

Middle & Bottom Shelf

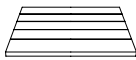

F 2 pcs.

Front Leg Assembly



G 1 pc.

Back Leg Assembly

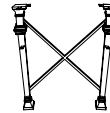

H 1 pc.

Be sure to check all packing material carefully for small parts, which may have come loose inside the carton during shipment.

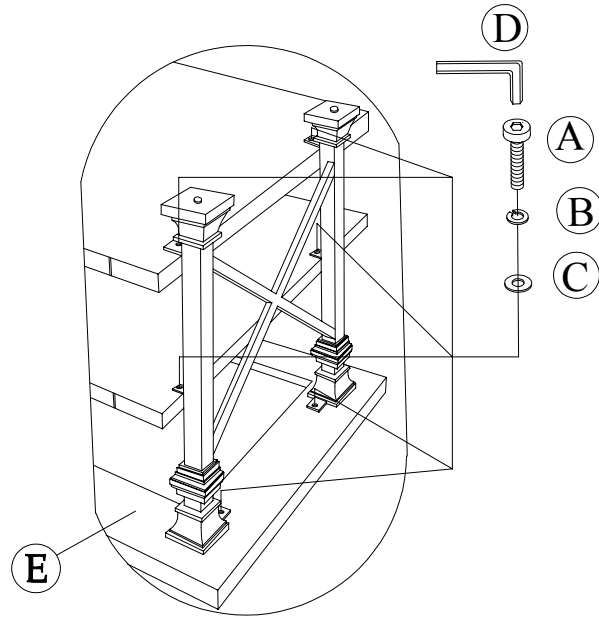
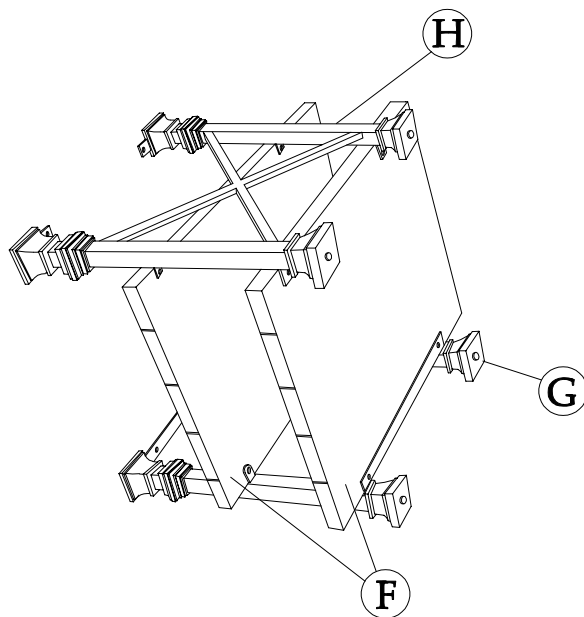

1. Do not discard any packing materials until the table has been completely assembled, to prevent parts from being accidentally discarded. To prevent possible scratches or damages, assemble the Table on a soft surface such as a blanket or carpet, or it's own packaging materials.
2. Position the Front Leg Assembly (G) (or Back Leg Assembly) face down.
3. Attach the Middle Shelf and Bottom Shelf (F) to the tabs on the Front (or Back) Leg Assembly using the Flat Washers (C), Spring Washers (B), and Allen Head Bolts (A). Do not fully tighten Bolts until the entire table has been assembled.
4. Position the remaining Leg Assembly onto the edge of Shelves and attach using the same Flat Washers (C), Spring Washers (B), and Allen Head Bolts (A) as in previous step. Do not fully tighten Bolts.
5. Place the Top (E) upside down. Carefully place the assembled Table onto the table Top. Attach the assembled Table to the Top using the same Bolts and Washers as Before.
6. Tighten all the Bolts using the Allen Wrench (D).
7. Carefully set the assembled Table upright.
8. Levelers are installed into the bottom of the Leg Assemblies and can be used to compensate for uneven flooring if necessary.