













# ASSEMBLY INSTRUCTIONS

## 45008 END TABLE

### COMPONENT AND PARTS LIST

1	TOP & APRON	1 PC
2	METAL LEG	4 PCS
3	BOTTOM SHELF	1 PC
4	METAL SCROLL	2 PCS
5	DRAWER	1 PC

#	HARDWARE		QTY	EXT
A	M5/16" X 1-3/8 ALLEN-HEAD BOLT		4 PCS	1 PC
B	M5/16" SPRING WASHER		8 PCS	1 PC
C	M5/16" X 22MM FLAT WASHER		4 PCS	1 PC
D	5mm ALLEN WRENCH		1 PC	
E	M1/4" X 3/4" ALLEN-HEAD BOLT		4 PCS	1 PC
F	M1/4" SPRING WASHER		4 PCS	1 PC
G	M1/4" FLAT WASHER		4 PCS	1 PC
H	4mm ALLEN WRENCH		1 PC	
I	M5/16" X 3/4 ALLEN-HEAD BOLT		4 PCS	1 PC
J	M5/16" X 18MM FLAT WASHER		4 PCS	1 PC
K	SMALL KNOB		1 PC	
L	LARGE KNOB		1 PC	
M	M5/32" X 3/4" HARDWARE SCREW		1 PC	

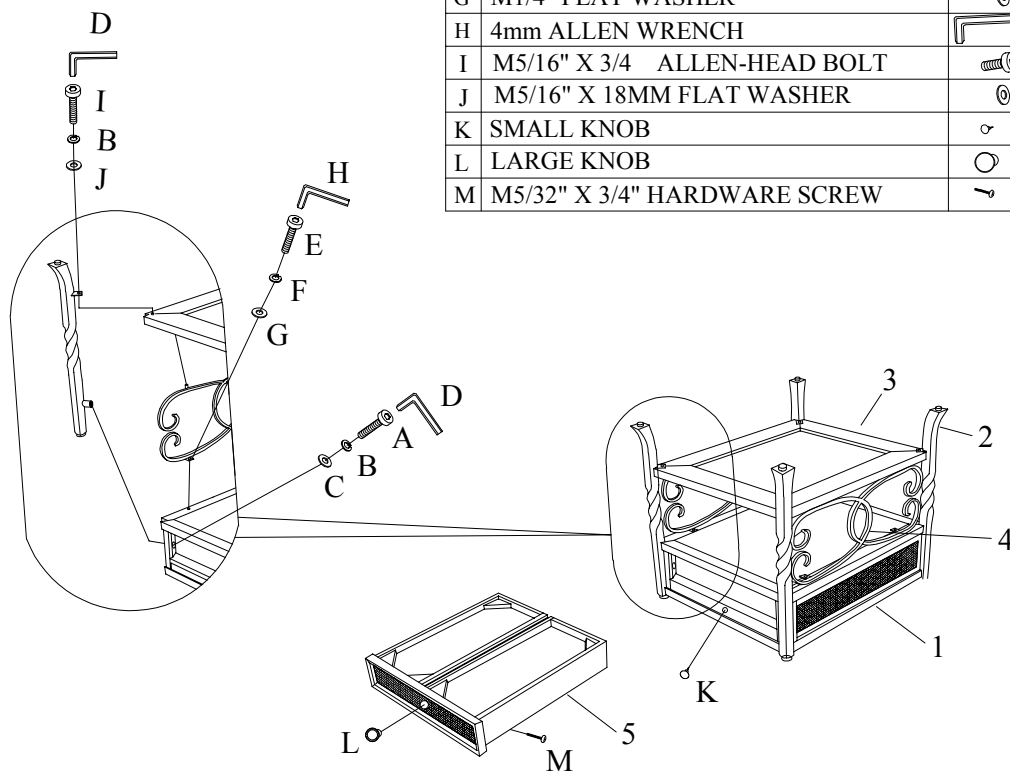

#### Note:

- Do not discard any packing materials until the table has been completely assembled, to prevent parts from being accidentally discarded.
- To prevent possible scratches or damage, assemble the table upside down on a soft surface such as a blanket or carpet.
- Remove the Drawer and lay it aside.
- Attach Metal Legs to the Top & Apron using four 1-3/8" Allen-Head bolts (A), Spring Washers (B), and Flat Washers (C), into the inside corner of the legs. Only partially install bolts until after step #7.
- Attach Metal Scroll to bottom side of Top & Apron using two 1/4" x 3/4" Allen-Head Bolts (E), Spring Washers (F) and Flat Washers (G). Do not fully tighten until after step #7.
- Place Wood Shelf onto the locator pins on the bottom of the Metal Scroll.
- Attach the Bottom Shelf to the Metal Legs using the four 5/16" x 3/4" long Allen-Head bolts (I), Spring Washers (B) and Flat Washers (J).
- Tighten all bolts using the supplied Allen Wrenches, (D or H).
- Carefully turn the Table upright and reinstall the drawer.