

ASSEMBLY INSTRUCTIONS
INSTRUCTIONS DE MONTAGE
INSTRUCCIONES DE ENSAMBLAJE

5353

Mobile File Cart with Locking Top
Moblie Dossier Charrette avec Verrouillage du
Couvercle
Móvil Archivo Carreta con Tapa Cerradero

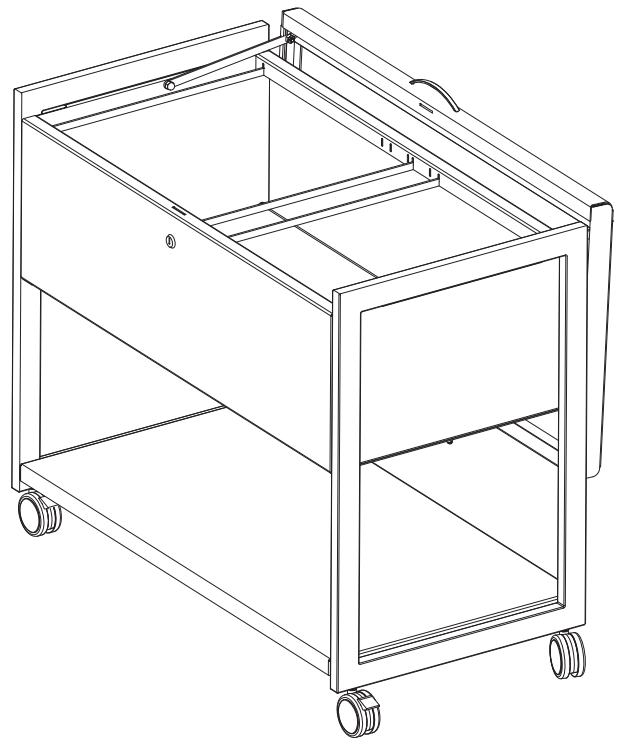
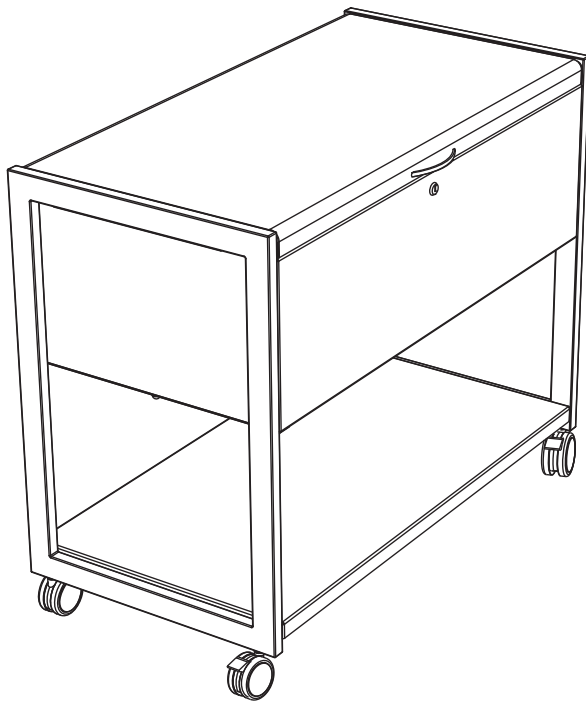

PRODUCT WARRANTY REGISTRATION is available online at: www.safcoproducts.com

• L'INSCRIPTION POUR LA GARANTIE DU PRODUIT est disponible sur l'Internet : www.safcoproducts.com

• EI REGISTRO PARA LA GARANTÍA DEL PRODUCTO está disponible en la Internet: www.safcoproducts.com

For questions or concerns, please call **1-800-664-0042**
available Monday-Friday 7:00 AM to 6:00 PM (Central Time) (English-speaking operators)

Si vous avez des questions pour poser ou les préoccupations
pour exprimer, connecter **au 1-800-664-0042**
de 7H00 à 18H00 (Heure centrale) (Opérateurs de langue anglaise)

Si usted tiene preguntas o preocupaciones,
por favor llame **1-800-664-0042**
de 7:00 AM a 6:00 PM (Hora Central) (Operadores que hablan inglés)

PARTS LIST

CODE	DESCRIPTION	QTY	PART NO.
(A)	File Box, Right Side	1	5353-03BL
(B)	File Box, Left Side	1	5353-04BL
(C)	File Box Front	1	5353-05BL
(D)	File Box Back	1	5353-06BL
(E)	File Box Lid	1	5353-07BL
(F)	Lid Support	1	5353-08BL
(G)	Shelf	1	5353-09BL
(H)	File Box Bottom	1	5353-10BL
(I)	Rail Sleeves	4	5353-11NC
(J)	File Hanger	4	5353-12NC
(K)	Set of 2 Keys(not shown)	1	5353-14NC
(L)	Lid sleeve	2	5353-15NC

LISTE DES PIÈCES











CODE	DESCRIPTION	QUANTITÉ	N° DE PIÈCE
(A)	Dossier boîte, côté droit	1	5353-03BL
(B)	Dossier boîte, côté gauche	1	5353-04BL
(C)	Dossier boîte, devant	1	5353-05BL
(D)	Dossier boîte, arrière	1	5353-06BL
(E)	Charrette de cadre, couvercle	1	5353-07BL
(F)	Couvercle support	1	5353-08BL
(G)	Étagère	1	5353-09BL
(H)	Dossier boîte, inférieur	1	5353-10BL
(I)	Rail manchon	4	5353-11NC
(J)	Dossier cintre	4	5353-12NC
(K)	Ensemble de 2 clés (non montré)	1	5353-14NC
(L)	Couvercle manchon	2	5353-15NC

LISTA DE PIEZAS

CODIGO	DESCRIPCIÓN	CANTIDAD	NO. DE PIEZA
(A)	Archivos caja, lateral derecho	1	5353-03BL
(B)	Archivos caja, lateral izquierdo	1	5353-04BL
(C)	Archivos caja, delante	1	5353-05BL
(D)	Archivos caja, atrás	1	5353-06BL
(E)	Archivos caja tapa	1	5353-07BL
(F)	Apoyo tapa	1	5353-08BL
(G)	Estante	1	5353-09BL
(H)	Fondo del archivo caja	1	5353-10BL
(I)	Reil manga	4	5353-11NC
(J)	Percha carpeta	4	5353-12NC
(K)	Juego de 2 llaves (no demostrado)	1	5353-13NC
(L)	La protector para el tapa	2	5353-15NC

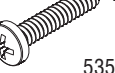









HARDWARE PACK 5353-19NC

TOOLS REQUIRED:
Flat-bladed Screwdriver
Phillips Screwdriver
Hammer
Box wrench

M  Screw Qty.: 12 5352-22NC	N  Acorn Nut Qty.: 4 5353-22NC	
O  Lid Handle Qty.: 1 5353-13CR	P  Handle screw Qty.: 2 5353-25NC	
Q  Non-Locking Caster Qty.: 2 5360-25BL	R  Locking Caster Qty.: 2 5360-26BL	S  Medium Screw Qty.: 2 5353-23NC
T  Screw Sleeve Qty.: 2 5353-26NC	U  Flat Washer Qty.: 2 5353-27NC	V  Small Screw Qty.: 2 5353-28NC

OUTILS REQUIS :
Tournevis plat à lame
tournevis à pointe cruciforme
Marteau
Boîte de fin clef



Paquet matériel 5353-19NC

M  Vis Qté.: 12 5352-22NC	N  Écrou borgne Qté.: 4 5353-22NC	
O  Poignée Qté.: 1 5353-13CR	P  Vis pour poignée Qté.: 2 5353-25NC	
Q  Roulette sans frein Qté.: 2 5360-25BL	R  Roulette avec frein Qté.: 2 5360-26BL	S  Vis moyen Qty.: 2 5353-23NC
T  Manchon pour vis Qty.: 2 5353-26NC	U  Rondella plate Qty.: 2 5353-27NC	V  Petit vis Qty.: 2 5353-28NC

HERRAMIENTAS REQUERIDAS:

Piso aspas destornillador
Destornillador Phillips
Martillo
Cuadro de llave

Paquete material 5353-19NC

M  Tornillo Cant.: 12 5352-22NC	N  Tuerca ciega Cant.: 4 5353-22NC	
O  Asa Cant.: 1 5353-13CR	P  Tornillo para asa Cant.: 2 5353-25NC	
Q  Rueda sin freno Cant.: 2 5360-25BL	R  Rueda con freno Cant.: 2 5360-26BL	S  Tornillo medio Qty.: 2 5353-23NC
T  Manga para tornillo Qty.: 2 5353-26NC	U  Arandela plana Qty.: 2 5353-27NC	V  Pequeño tornillo Qty.: 2 5353-28NC

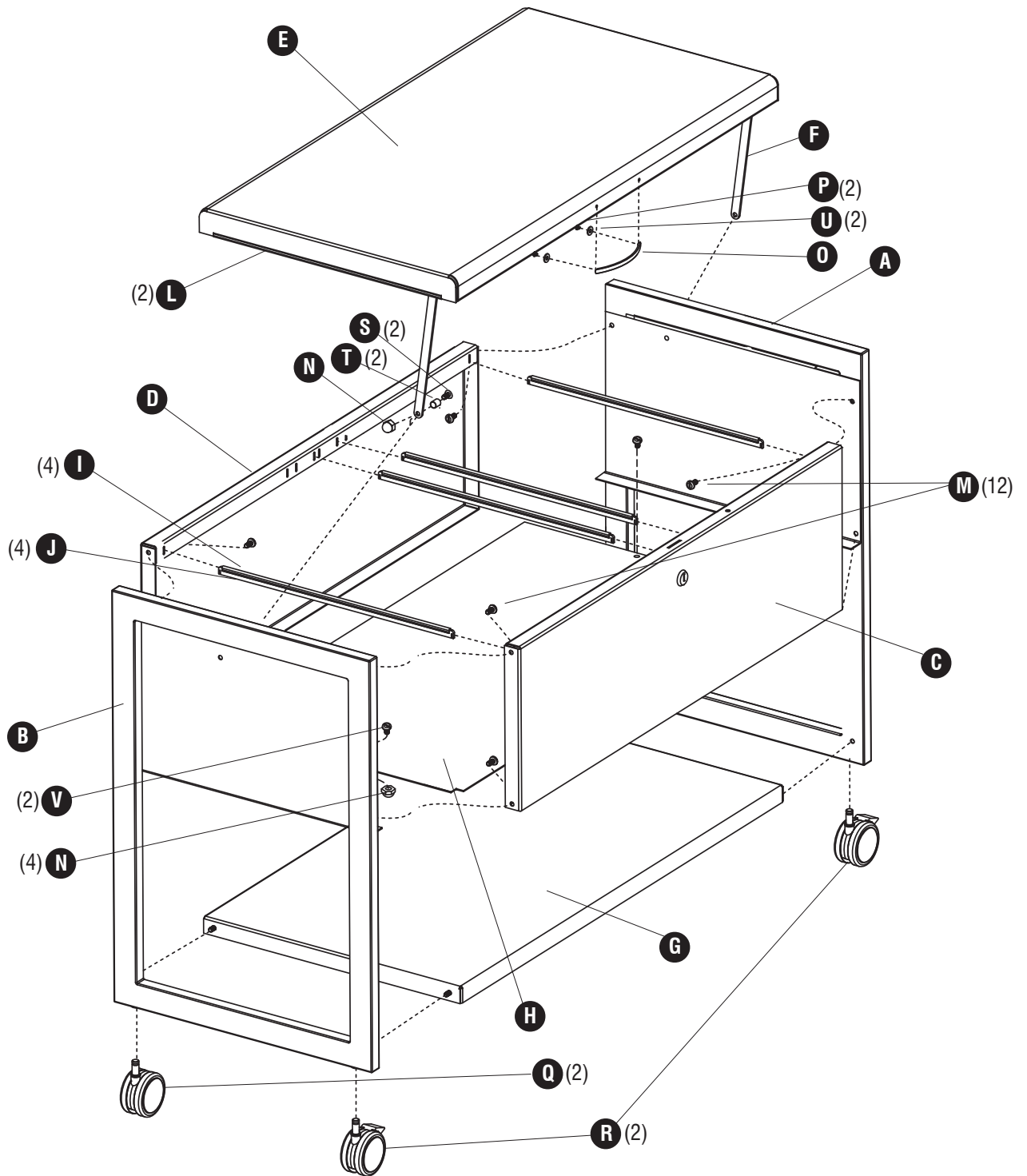

1

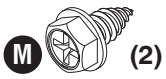

Lock.
Serrure
Cerradura

Hole must be placed furthest from panel with lock.
Trou doit être placé le plus éloigné du panneau avec le serrure.
Agujero se deben poner más lejos de la panel que contiene el cerradura

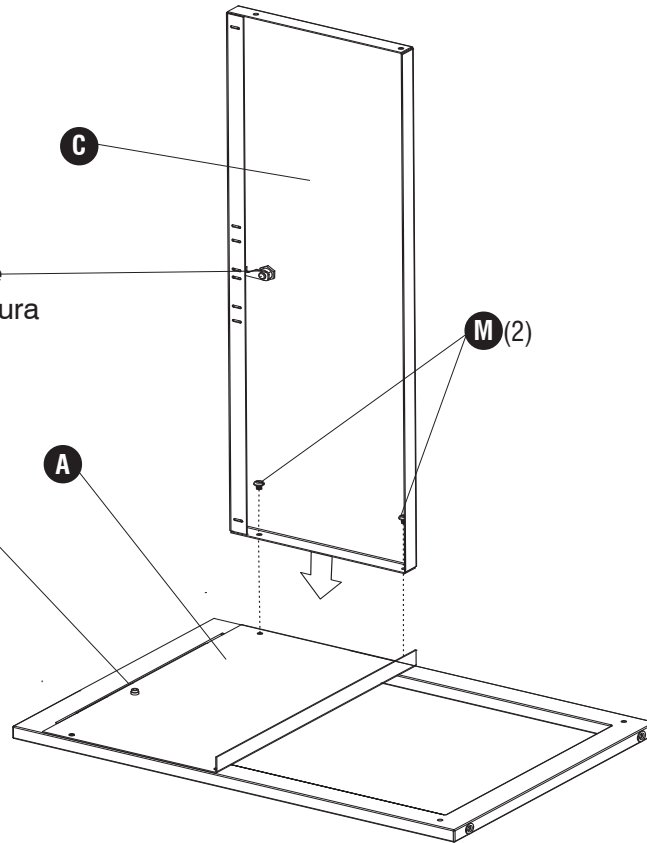

2

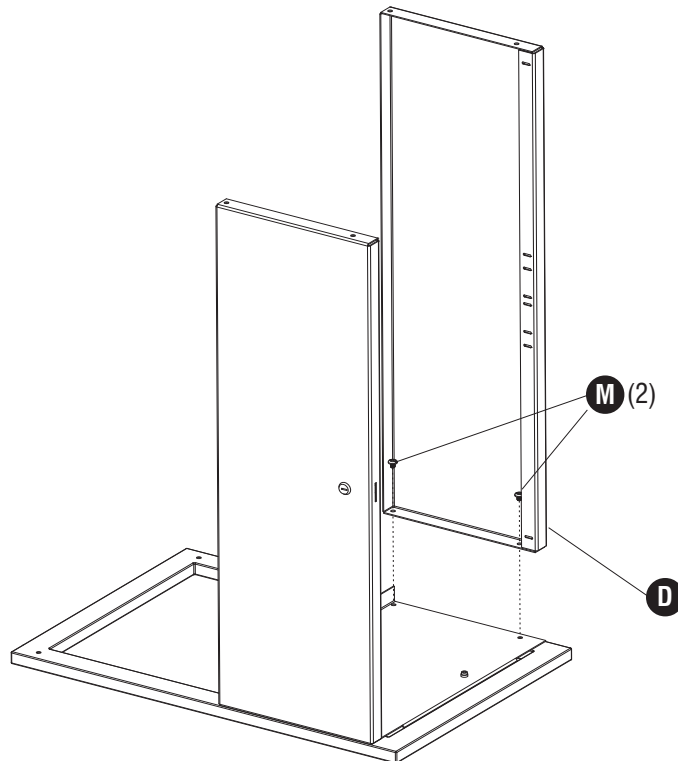
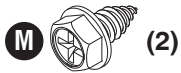

3 **M** (2)

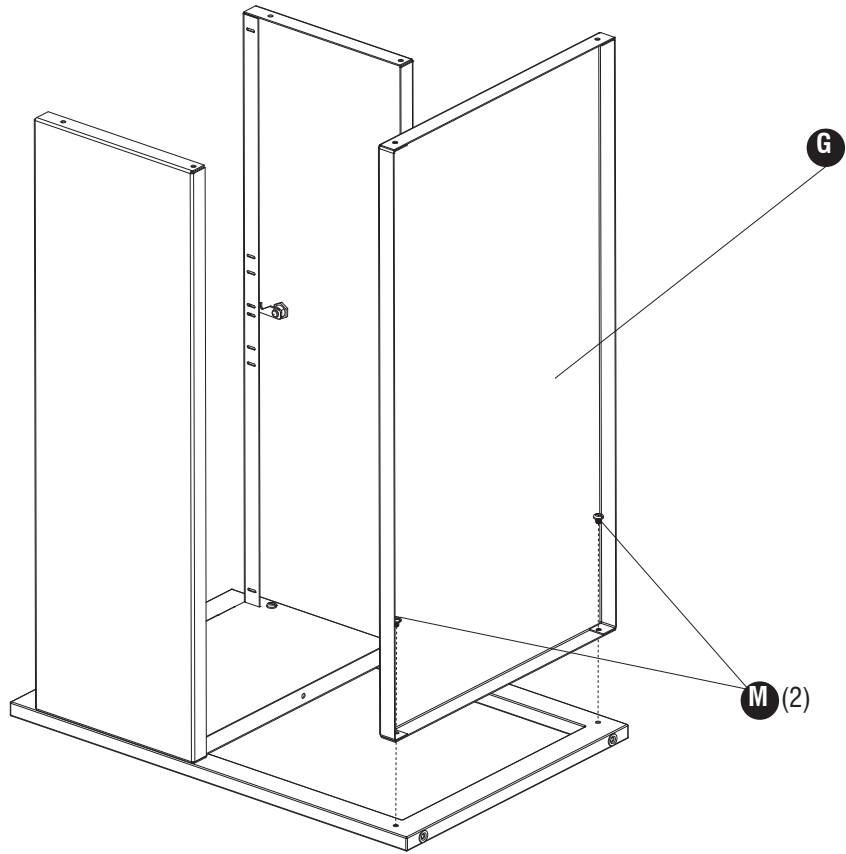

4 **Q** (2) **R** (2) **M** (6)

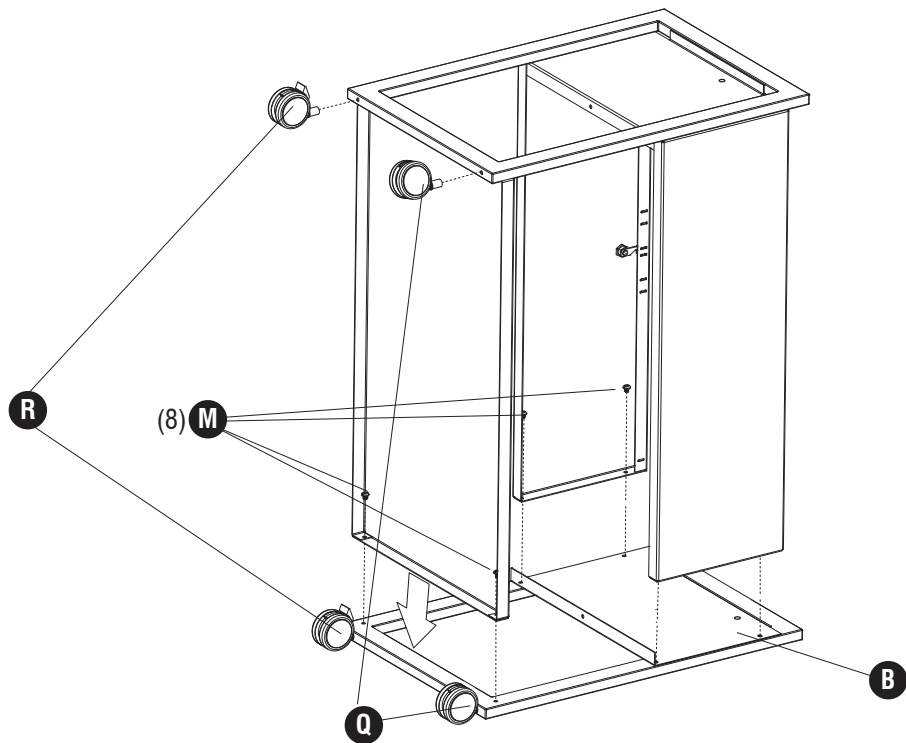
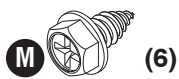

5

V



N



(2)

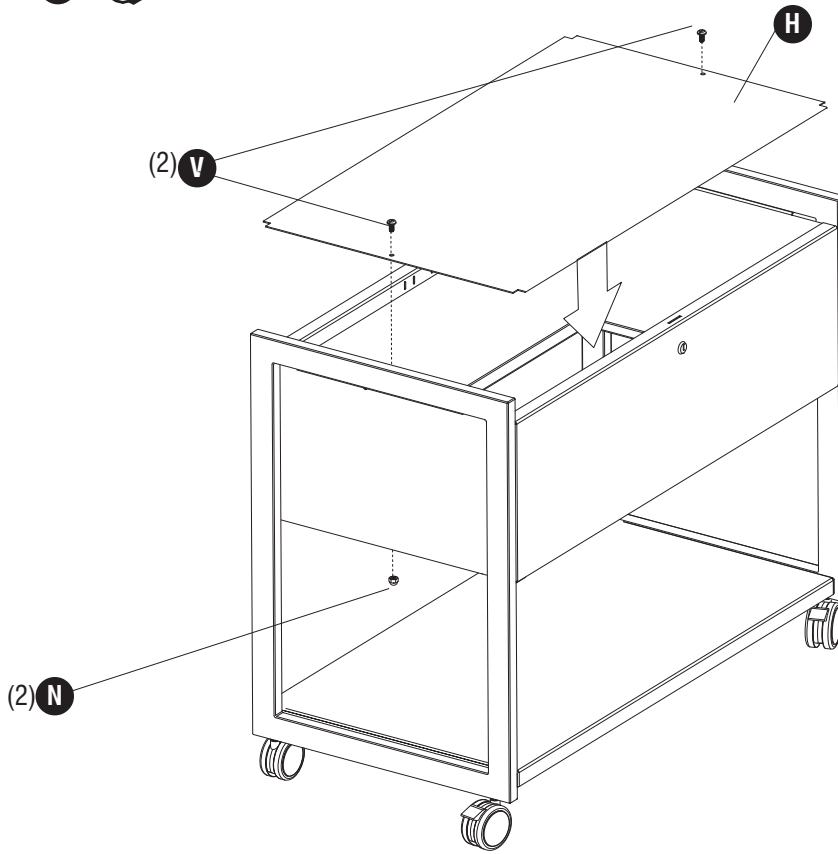

6

O



(1)

P



(2)

U



(2)

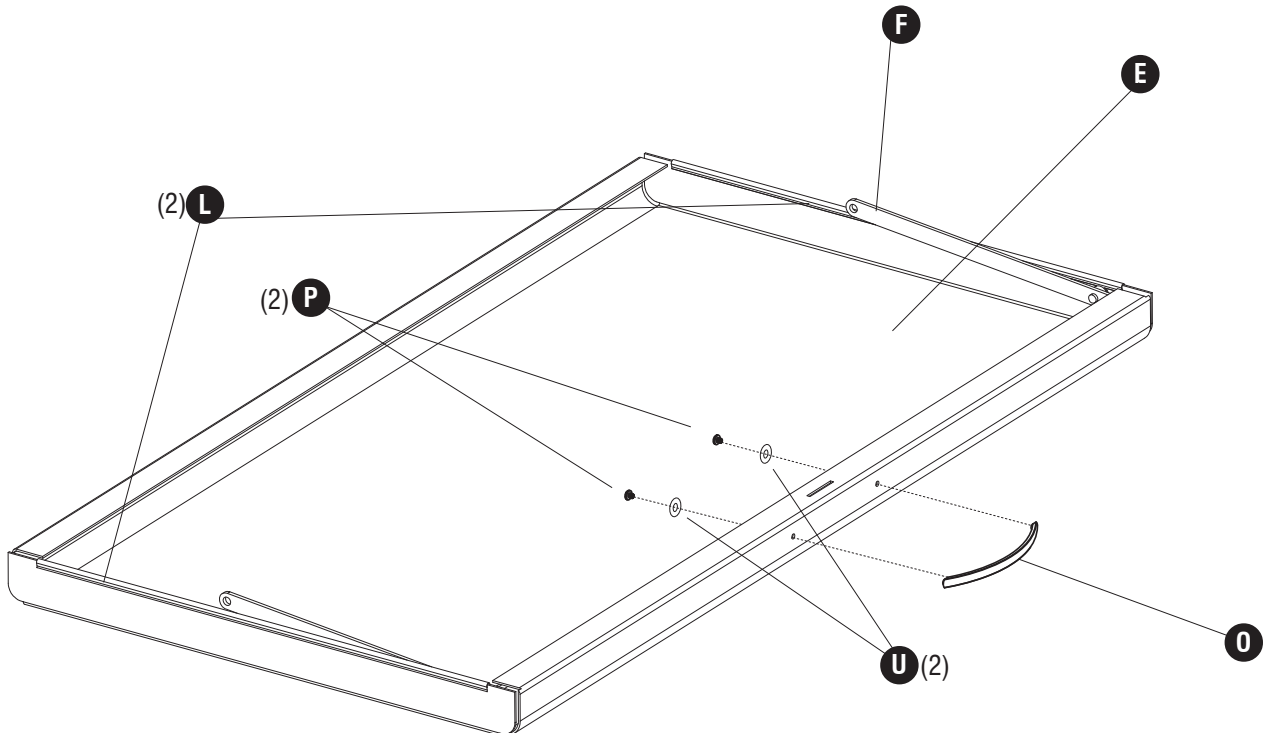

- 7** **S** (2) **T** (2) **N** (2)

