

ASSEMBLY INSTRUCTIONS

INSTRUCTIONS DE MONTAGE

INSTRUCCIONES DE ENSAMBLAJE

2143

Premier Series Keyboard Platform with Control Zone

"Premier Series" Plate-forme pour le clavier avec la zone de commande

"Premier Series" Plataforma para el teclado con zona del control

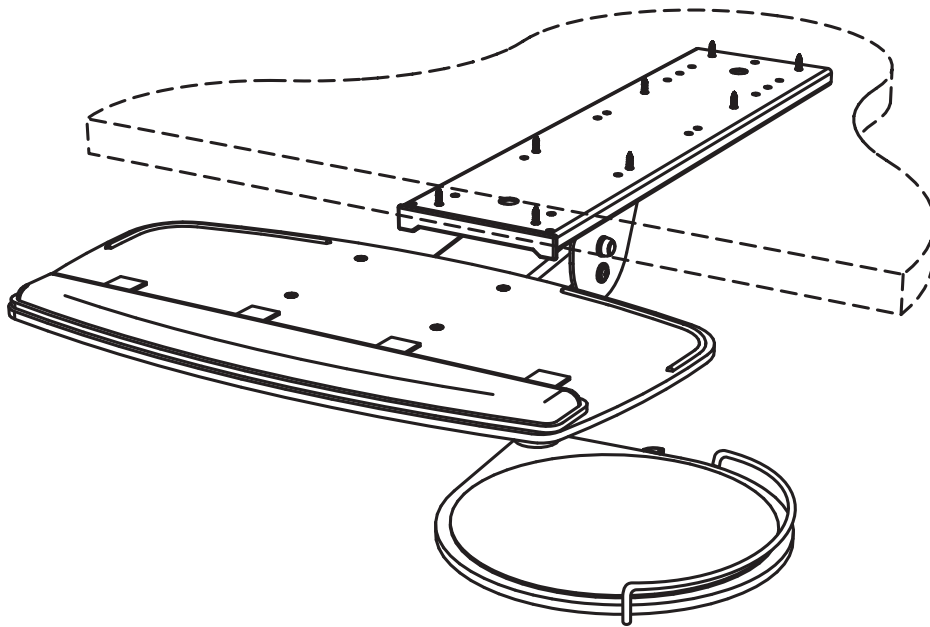

PRODUCT WARRANTY REGISTRATION is available online at: www.safcoproducts.com

• L'INSCRIPTION POUR LA GARANTIE DU PRODUIT est disponible sur l'Internet : www.safcoproducts.com

• EI REGISTRO PARA LA GARANTÍA DEL PRODUCTO está disponible en la Internet: www.safcoproducts.com

For questions or concerns, please call **1-800-664-0042**
available Monday-Friday 7:00 AM to 6:00 PM (Central Time) (English-speaking operators)

Si vous avez des questions pour poser ou les préoccupations pour exprimer, connecter **au 1-800-664-0042**
de 7H00 à 18H00 (Heure centrale) (Opérateurs de langue anglaise)

Si usted tiene preguntas o preocupaciones, por favor llame **1-800-664-0042**
de 7:00 AM a 6:00 PM (Hora Central) (Operadores que hablan inglés)

TOOLS REQUIRED: Phillips Screwdriver, Adjustable Wrench, Pencil, Drill with 1/8" bit, Masking Tape

OUTILS REQUIS: Tournevis à pointe cruciforme, Clef ajustable, Crayon, Perceuse avec mèche de 3 mm, Ruban de papier adhésif

• **HERRAMIENTAS REQUERIDAS:** Destornillador Phillips®, Llave ajustable, Lápiz, Taladro con broca de 1/8 pulg., Cinta de ADHESIVA PINTOR

PARTS LIST / LISTE DES PIÈCES / LISTA DE PIEZAS			
CODE / CÓDIGO	DESCRIPTION / DESCRIPTION / DESCRIPCIÓN	QTY. / QUANTITÉ / CANTIDAD	PART NO. / N° DE PIECE / NO. DE PIEZA
(A)	Track / Rail / Soporte	1	2143-06NC
(B)	Mechanism / Mécanisme / Mecanismo	1	2143-05NC
(C)	Keyboard Tray / Plateau de clavier / Bandeja de teclado	1	2143-01§
(D)	Mouse Platform / Plateau de souris / Plataforma de ratón	1	2143-04§
(E)	Wristrest / Repose-poignet / Descansabrazos	1	2143-10BL
	Hardware Pack / Paquet matériel / Paquete material	1	2143-19NC
	Hardware Pack / Paquet matériel / Paquete material	1	2143-98NC
	Hardware Pack / Paquet matériel / Paquete material	1	2143-99NC





§ Note: When corresponding about parts, be sure to state color:







Black (BL), Cherry (CY) or Mahogany (MH).





§ Noter: Quand correspondre au sujet de parties, soyez sûr d'affirmer la couleur:

Noir (BL), Cerise (CY) ou Acajou (MH).

§ Note: Al corresponder sobre las piezas, esté seguro declarar el color:

HARDWARE PACK / PAQUET MATÉRIEL / PAQUETE MATERIAL 2143-19NC			
 F Track Guard Clef Allen Llave Allen Qty. / Qte. / Cant.: 1 #2143-12NC	 G Sharp Screw Vis pointue Tornillo agudo Qty. / Qte. / Cant.: 9 #2143-23NC	 H Blunt Screw Vis mal taillé Tornillo embotado Qty. / Qte. / Cant.: 2 #2143-22NC	 I Bumper Pare-chocs Parachoques Qty. / Qte. / Cant.: 1 #2145-12NC

HARDWARE PACK / PAQUET MATÉRIEL / PAQUETE MATERIAL 2143-98NC			
 J Thin Plastic Washer Rondelle en plastique mince Arandela plástica fina Qty. / Qte. / Cant.: 2 #2143-29NC	 K Thick Plastic Washer Rondelle en plastique épaisse Arandela plástica gruesa Qty. / Qte. / Cant.: 1 #2143-30NC	 L Steel Washer Rondelle en acier Arandela de acero Qty. / Qte. / Cant.: 1 #2143-31NC	 M Allen Screw Vis Allen Tornillo Allen Qty. / Qte. / Cant.: 1 #2143-21NC
 N Large Nut Grand écrou Tuerca grande Qty. / Qte. / Cant.: 1 #2143-20NC	 O Allen Wrench Clef Allen Llave Allen Qty. / Qte. / Cant.: 1 #2143-33NC	 P Acorn Nut Écrou borgne Tuerca ciega Qty. / Qte. / Cant.: 1 #2143-32NC	

HARDWARE PACK / PAQUET MATÉRIEL / PAQUETE MATERIAL 2143-99NC			
 Q Flat Head Screw Vis à tête plate Tornillo de cabeza llana Qty. / Qte. / Cant.: 4 #2143-27NC	 R Small Nut Petit écrou Tuerca pequeña Qty. / Qte. / Cant.: 4 #2143-28NC	 S Non-Skid Pad Protection antidérapante Cojín antideslizante Qty. / Qte. / Cant.: 4 #2143-26NC	 T Cable Clip Collier de câble Clip de cable Qty. / Qte. / Cant.: 1 #2143-15NC

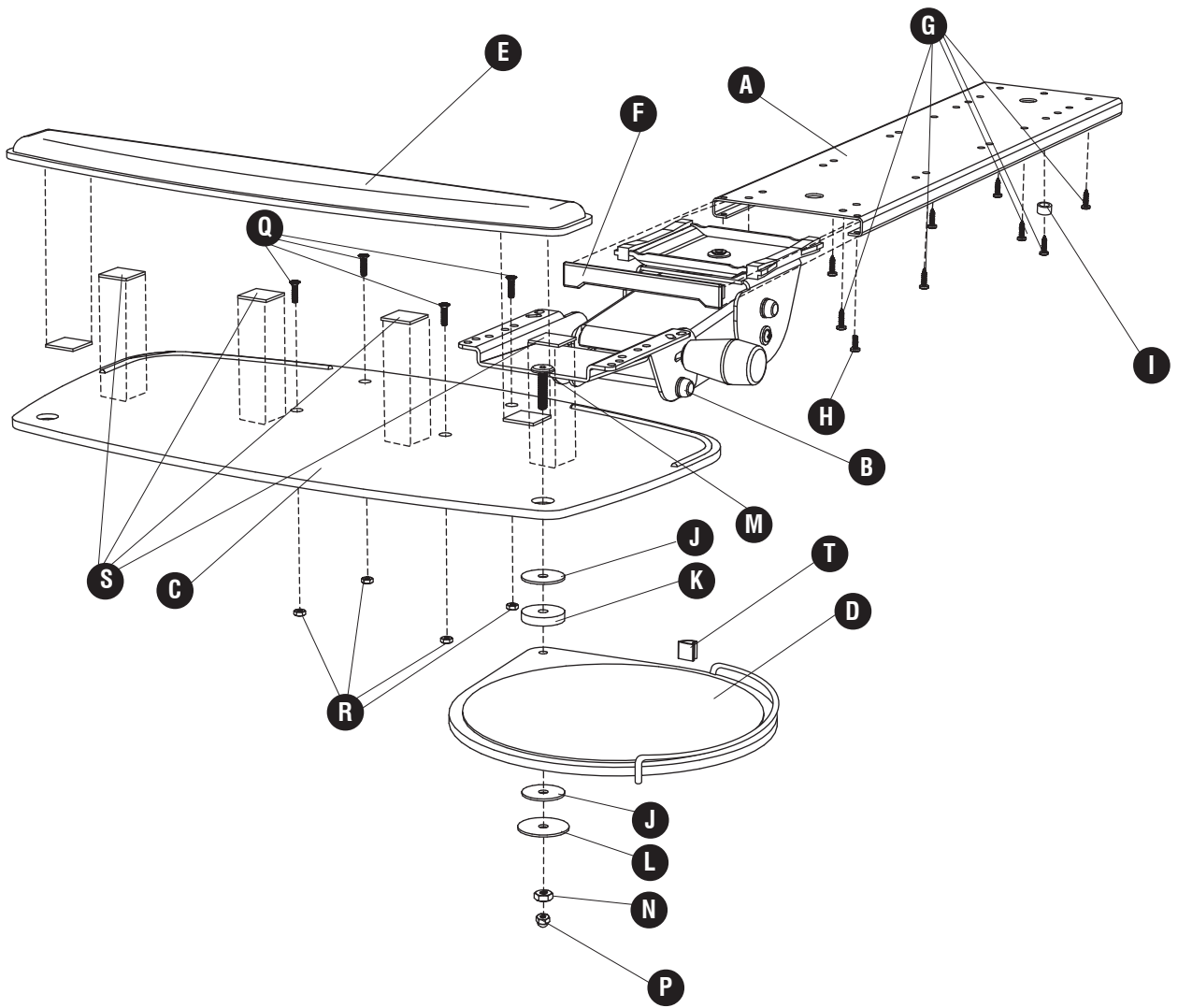

1

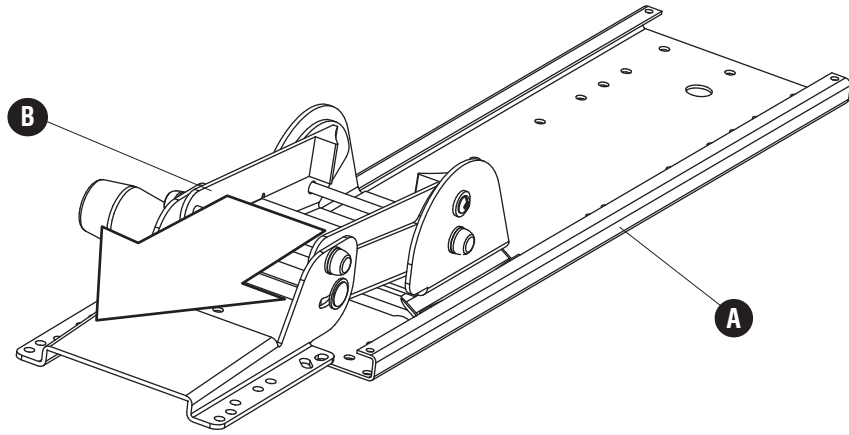

2 G (9) I (1)

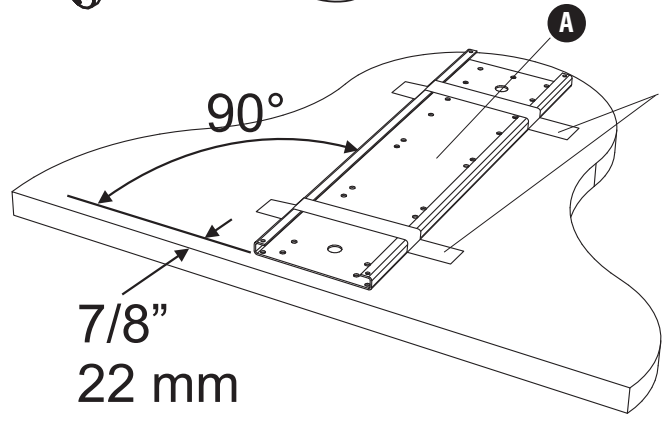

MASKING TAPE
RUBAN DE PAPIER ADHÉSIF
CINTA ADHESIVA DE PINTOR

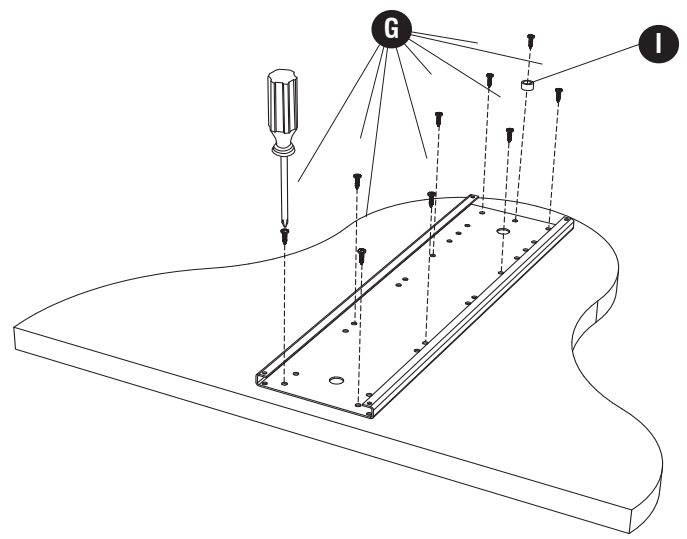
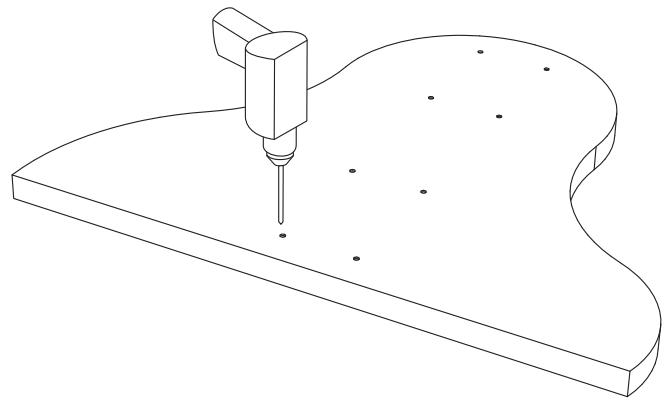
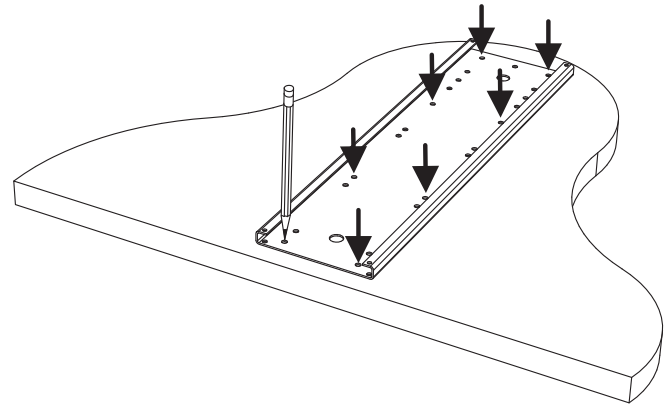

3

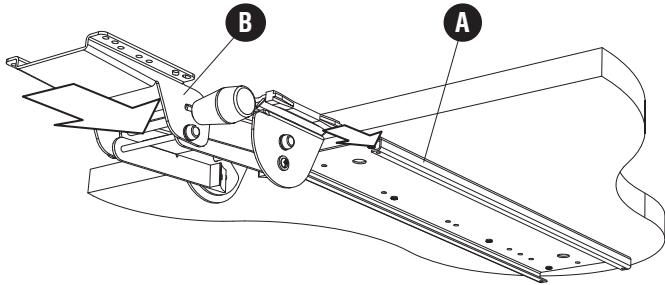

4 H (2)

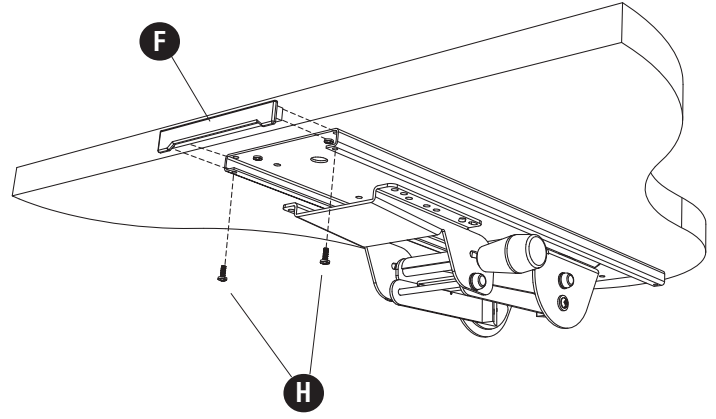

5 Q (4) R (4)

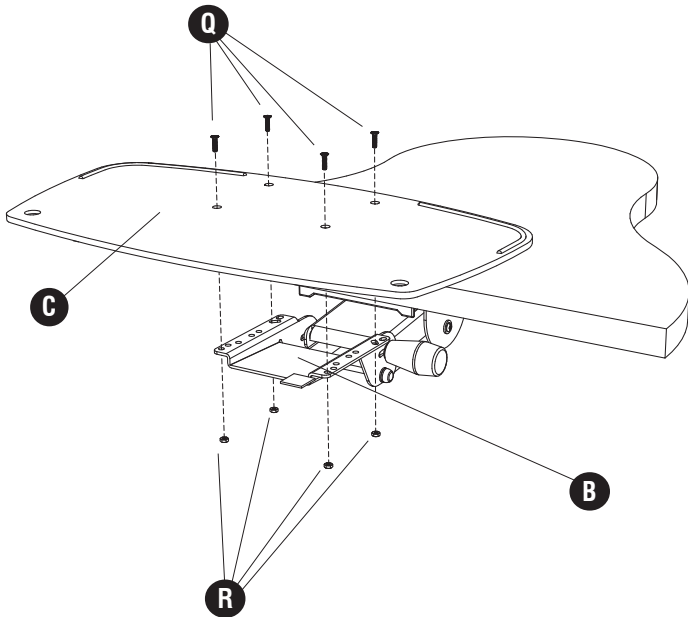

6 J (2) K (1) L (1)
M (1) N (1) P (1)

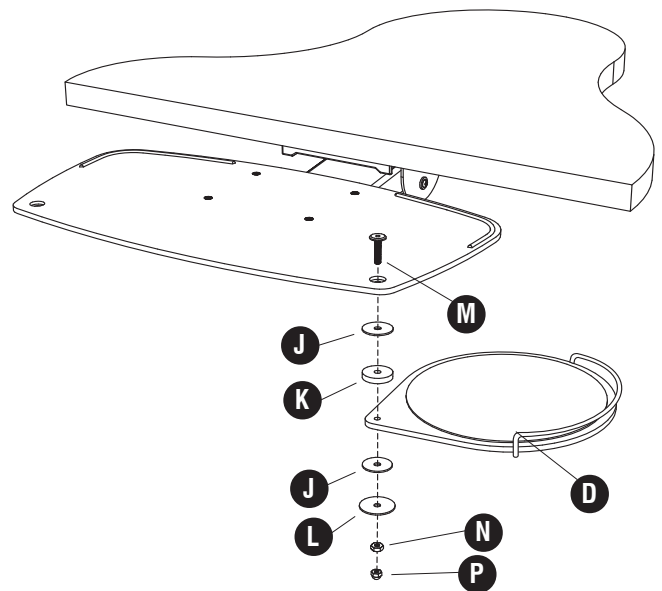

7 **S** (4) **T** (1)

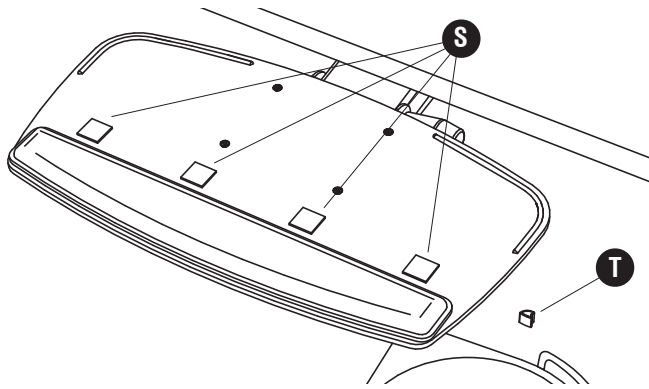

Arrange Wristrest and keyboard on Keyboard tray; attach Non-Skid Pads to Keyboard Tray under front edge of keyboard. Attach the cable clip where you desire.

Arranger le repose-poignet et le clavier sur le plateau de clavier ; attacher les protections antidérapantes au plateau de clavier sous le bord avant du clavier. Attacher le collier de câble où vous désirez.

Arreglar el descansabrazos y el teclado sobre la bandeja del teclado; unir los cojines antideslizantes a la bandeja del teclado bajo borde delantero del teclado. Unir el clip de cable donde desees.

8

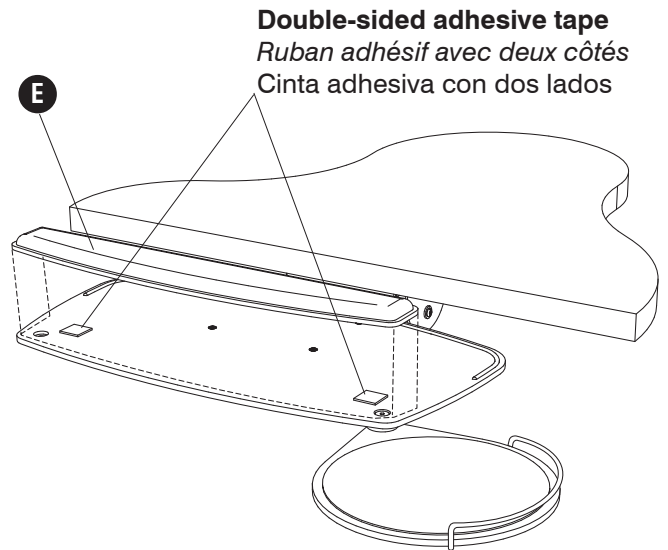

Remove clear protective sheet from bottom of wristrest; for permanent installation, use double-sided adhesive tape (included)

Enlever la feuille protectrice claire du fond de le repose-poignet ; pour l'installation permanente, employer le ruban adhésif avec deux côtés (inclus)

Quitar la hoja protectora clara del fondo del descansabrazos; para la instalación permanente, utilizar la cinta adhesiva con dos lados (incluidos)

9

- Tilt the Keyboard Tray slightly to push in or pull out.**
- Lift and press down or pull up to adjust the height; release to lock in place.**
- Loosen the tilt knob on the right side of the Mechanism, position the Keyboard Tray at the desired angle, and re-tighten the knob.**
- The Mechanism will also swivel to the left or right with a moderate push to the side.**

a) Incliner légèrement le plateau de clavier pour le faire entrer ou sortir.

b) Soulever et pousser vers le bas ou tirer vers le haut pour modifier la hauteur; relâcher pour bloquer le plateau en position.

c) Desserrer le bouton de réglage de l'inclinaison du côté droit du mécanisme, mettre le plateau à l'angle voulu, puis resserrer le bouton.

d) Le mécanisme peut également pivoter vers la gauche ou la droite si on le pousse légèrement sur le côté.

a) Al inclinar ligeramente la bandeja del teclado para empujarla o sacarla.

b) Levante y presione hacia abajo o hacia arriba para ajustar la altura. Suelte para bloquear en posición.

c) Afloje la perilla de inclinación en el lado derecho del mecanismo, coloque la bandeja del teclado en el ángulo deseado y apriete de nuevo la perilla.

d) El mecanismo también girará a la izquierda o derecha con un ligero empujón hacia un lado.

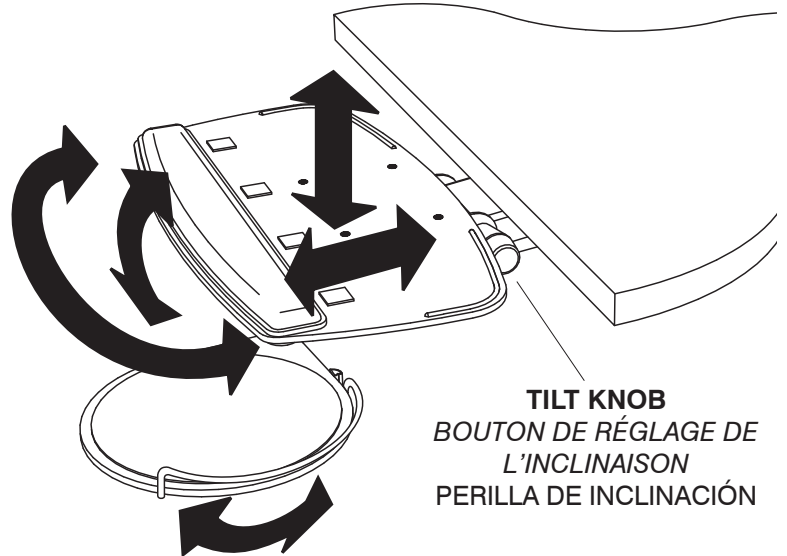

TILT KNOB
BOUTON DE RÉGLAGE DE
L'INCLINAISON
PERILLA DE INCLINACIÓN