

ASSEMBLY INSTRUCTIONS
INSTRUCTIONS DE MONTAGE
INSTRUCCIONES DE ENSAMBLAJE

5378
Impromptu[®]
Mobile Storage Center, Half Top
Centre de stockage mobile, Couvercle Partielle
Centro Móvil de almacenamiento, Tapa Parcial



PRODUCT WARRANTY REGISTRATION is available online at: www.safcoproducts.com

• L'INSCRIPTION POUR LA GARANTIE DU PRODUIT est disponible sur l'Internet : www.safcoproducts.com

• EI REGISTRO PARA LA GARANTÍA DEL PRODUCTO está disponible en la Internet: www.safcoproducts.com

For questions or concerns, please call **1-800-664-0042**
available Monday-Friday 7:00 AM to 6:00 PM (Central Time) (English-speaking operators)

Si vous avez des questions pour poser ou les préoccupations pour exprimer, connecter **au 1-800-664-0042**
de 7H00 à 18H00 (Heure centrale) (Opérateurs de langue anglaise)

Si usted tiene preguntas o preocupaciones, por favor llame **1-800-664-0042**
de 7:00 AM a 6:00 PM (Hora Central) (Operadores que hablan inglés)

TOOLS REQUIRED: Phillips Screwdriver
OUTILS REQUIS : Tournevis à pointe cruciforme
HERRAMIENTAS REQUERIDAS: Destornillador Phillips

Two People Recommended.

On recommande que l'assemblage soit effectué par deux personnes.

Se recomienda dos personas para el ensamblaje.

Parts List / Liste des Pièces / Lista de Piezas			
Code/ Código	DESCRIPTION / DESCRIPTION / DESCRIPCIÓN	Qty./ Qté/ Cant.	Part No./ N° de Pièce / No. de Pieza
(A)	Leg with Cap / <i>Pied avec Capuchon</i> / Pata con tapa	2	5376-03\$
(B)	Leg / <i>Pied</i> / Pata	2	5377-09\$
(C)	Side Panel, Left / <i>Panneau latéral, gauche</i> / Panel lateral, izquierda	1	5378-02\$
(D)	Side Panel, Right / <i>Panneau latéral, droit</i> / Panel lateral, derecha	1	5378-01\$
(E)	Back Panel / <i>Panneau arrière</i> / Tablero trasero	1	5377-02\$
(F)	Front Panel / <i>Panneau Frontal</i> / Tablero Frontal	1	5376-04\$
(G)	Door / <i>Porte</i> / Puerta	1	5377-06\$
(H)	Center Divider / <i>Centre Séparateur</i> / Centro Separador	1	5377-07\$
(I)	Bottom Shelf / <i>Étagère inférieur</i> / Estante del fondo	1	5377-04\$
(J)	Center Shelf / <i>Étagère central</i> / Estante central	1	5376-06\$
(K)	Top Panel / <i>Panneau supérieur</i> / Tablero superior	1	5378-03\$\$
(L)	File Bin / <i>Corbeille à Dossier</i> / Archivo Papelera	1	5376-07\$
(M)	Set of 2 Keys (Not shown) / <i>Lot de 2 clés</i> / Juego de 2 llaves	1	5377-10NC

§ **Note: When corresponding about parts, be sure to state color: Black (BL), or Gray (GR) .**









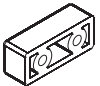

§ *Noter: Quand correspondre au sujet de parties, soyez sûr d'affirmer la couleur: Noir (BL) ou Gris (GR) .*

§ **Note: Al corresponder sobre las piezas, esté seguro declarar el color: Negro(BL) o Gris (GR).**

§§ **Note: When corresponding about parts, be sure to state color: Gray (GR), or Cherry (CY) .**

§§ *Noter: Quand correspondre au sujet de parties, soyez sûr d'affirmer la couleur: Gris (GR) ou Cerise (CY) .*

§§ **Note: Al corresponder sobre las piezas, esté seguro declarar el color: Gris (GR) o Cereza (CY).**

Hardware Pack / Paquet Matériel / Paquete Material: 5378-19\$			
N  Long Screw <i>Longue vis</i> Tornillo largo Qty. / Qté. / Cant. 12 5376-23\$	O  Small Screw <i>Vis petit</i> Tornillo pequeño Qty. / Qté. / Cant. 6 5377-21\$	P  Doorstop <i>Butoir</i> Tope Qty. / Qté. / Cant. 1 1859-13\$	Q  Magnetic Latch <i>Loquet Magnétique</i> Cierre Magnético Qty. / Qté. / Cant. 1 5377-15NC
R  Short Screw <i>Vis courte</i> Corto tornillo Qty. / Qté. / Cant. 2 1859-28\$	S  Medium Screw <i>Vis moyenne</i> Tornillo medio Qty. / Qté. / Cant. 2 5377-22\$	T  Hex Nut <i>Écrou hexagonal</i> Tuerca hexagonal Qty. / Qté. / Cant. 2 5377-23\$	U  Rail Sleeves <i>Rail manchon</i> Riel manga Qty. / Qté. / Cant. 2 5376-10NC
V  Screw for Magnet <i>Vis pour aimant</i> Tornillo de imán Qty. / Qté. / Cant. 2 5377-27\$	W  Small Hex Nut <i>Écrou hexagonal petit</i> Hexagonal Tuerca pequeño Qty. / Qté. / Cant. 2 5377-29\$		

Hardware Pack / Paquet Matériel / Paquete Material: 1857-99\$\$\$	
X  Caster With Brake <i>Roue avec Frein</i> Rueda con Freno Qty. / Qté. / Cant. 2 1857-26\$\$\$	Y  Caster Without Brake <i>Roue sans Frein</i> Rueda sin Freno Qty. / Qté. / Cant. 2 1857-25\$\$\$

§§§**Note: When corresponding about casters, be sure to state color: 2-Tone (NC) or Black (BL).**

§§§*Noter: Quand correspondre au sujet de roues, soyez sûr d'affirmer la couleur: Deux tons (NC) ou Noir (BL).*

§§§ **Note: Al corresponder sobre las ruedas, esté seguro declarar el color: Dos tonos (NC) o Negro (BL).**

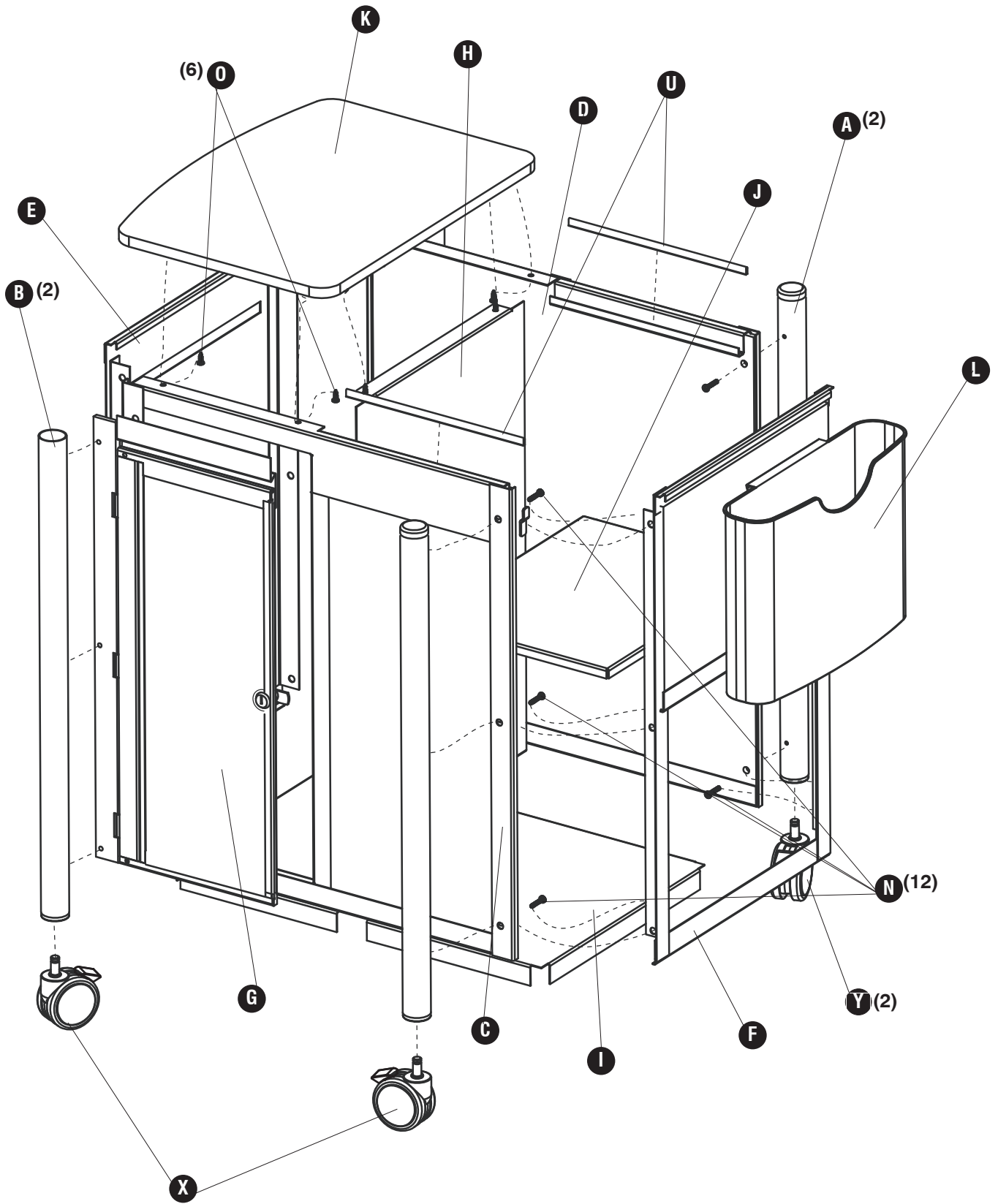

1 **N**  **(3)**

IMPORTANT: Orient the parts as shown!
Important: Vous devez orienter les pièces comme le montre!
¡¡IMPORTANTE! Usted debe orientar las piezas tal y como se muestra!

TOP FLANGE
BRIDE SUPÉRIEUR
REBORDE SUPERIOR

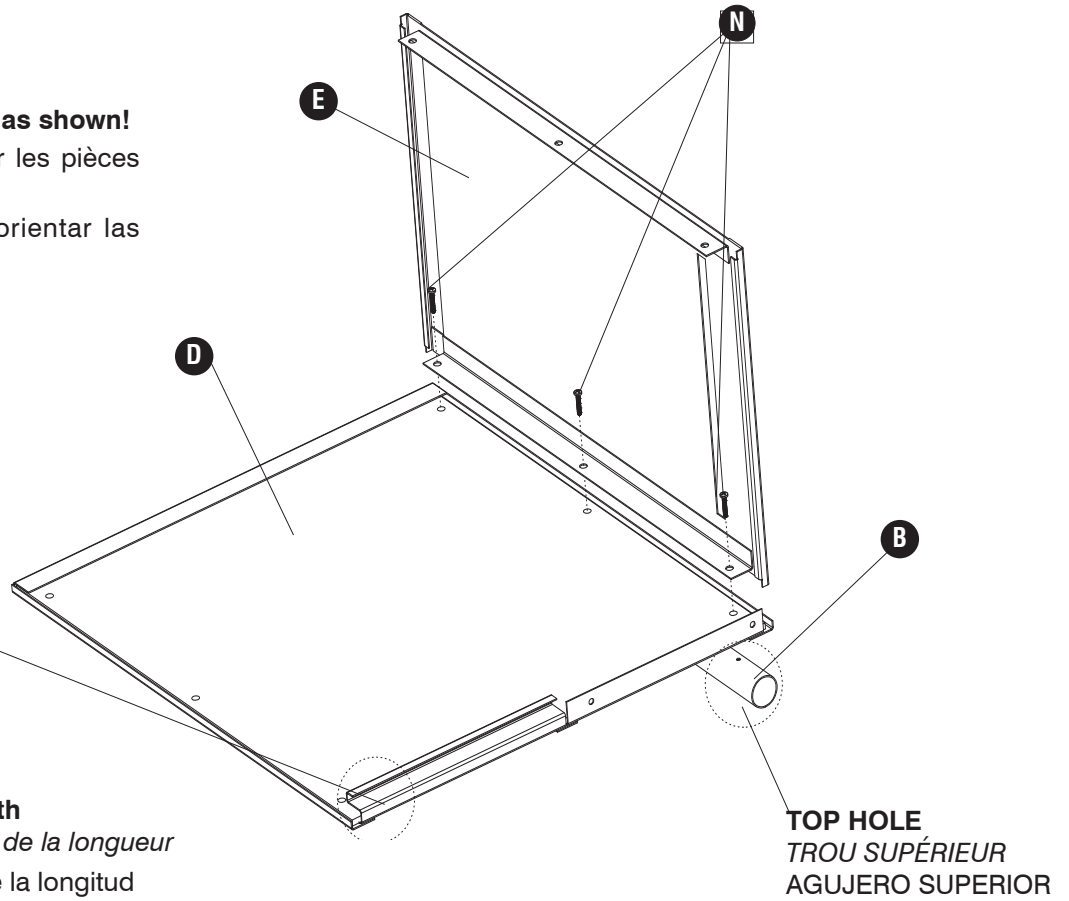

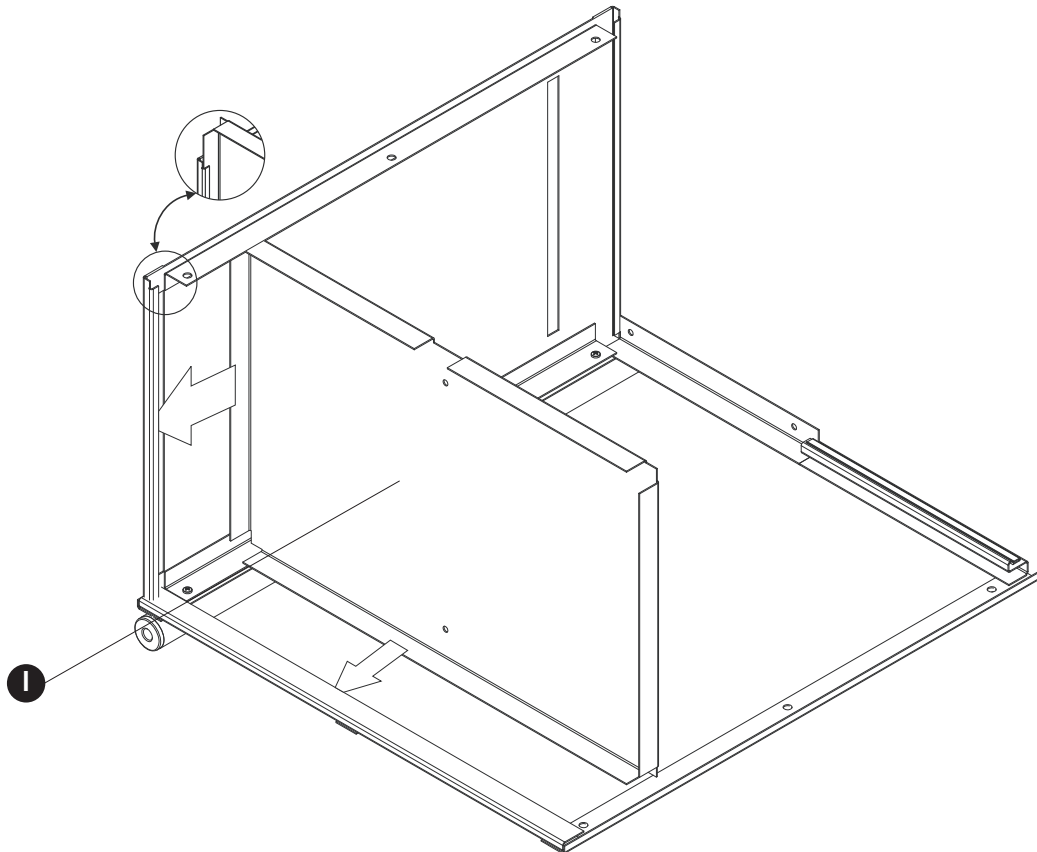

Insert screws only 2/3 of length
Insérer les vis à seulement 2 / 3 de la longueur
Inserte los tornillos sólo 2 / 3 de la longitud

2

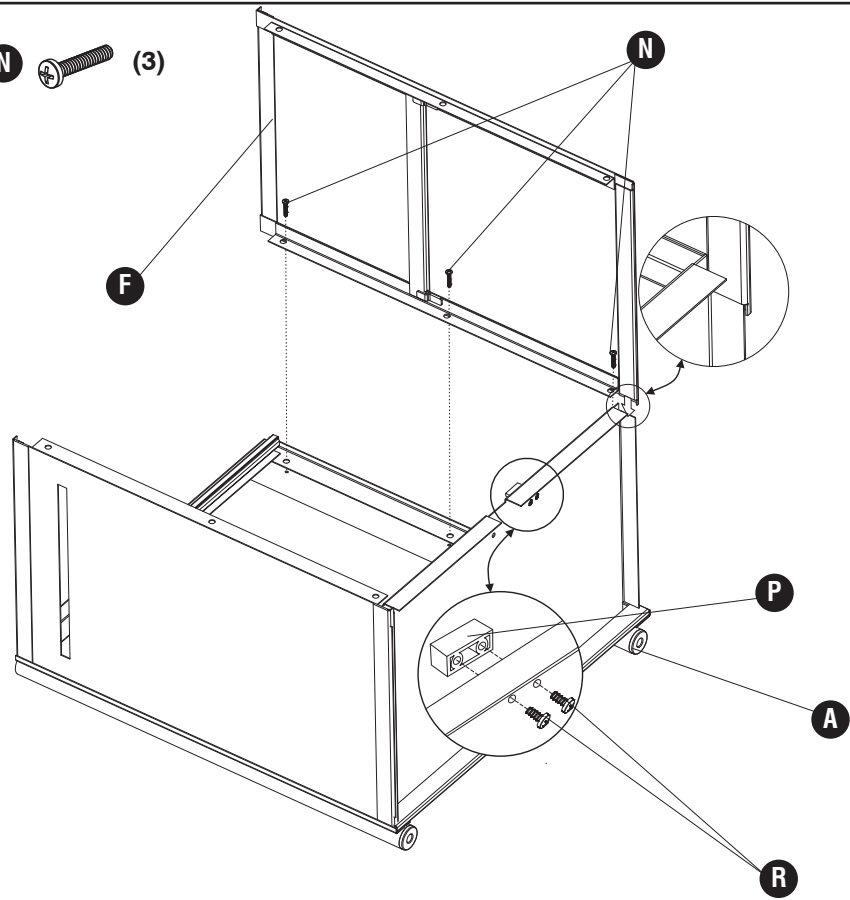

- 3** **P**  **R**  (2) **N**  (3)



- 4** **S**  (2) **T**  (2)

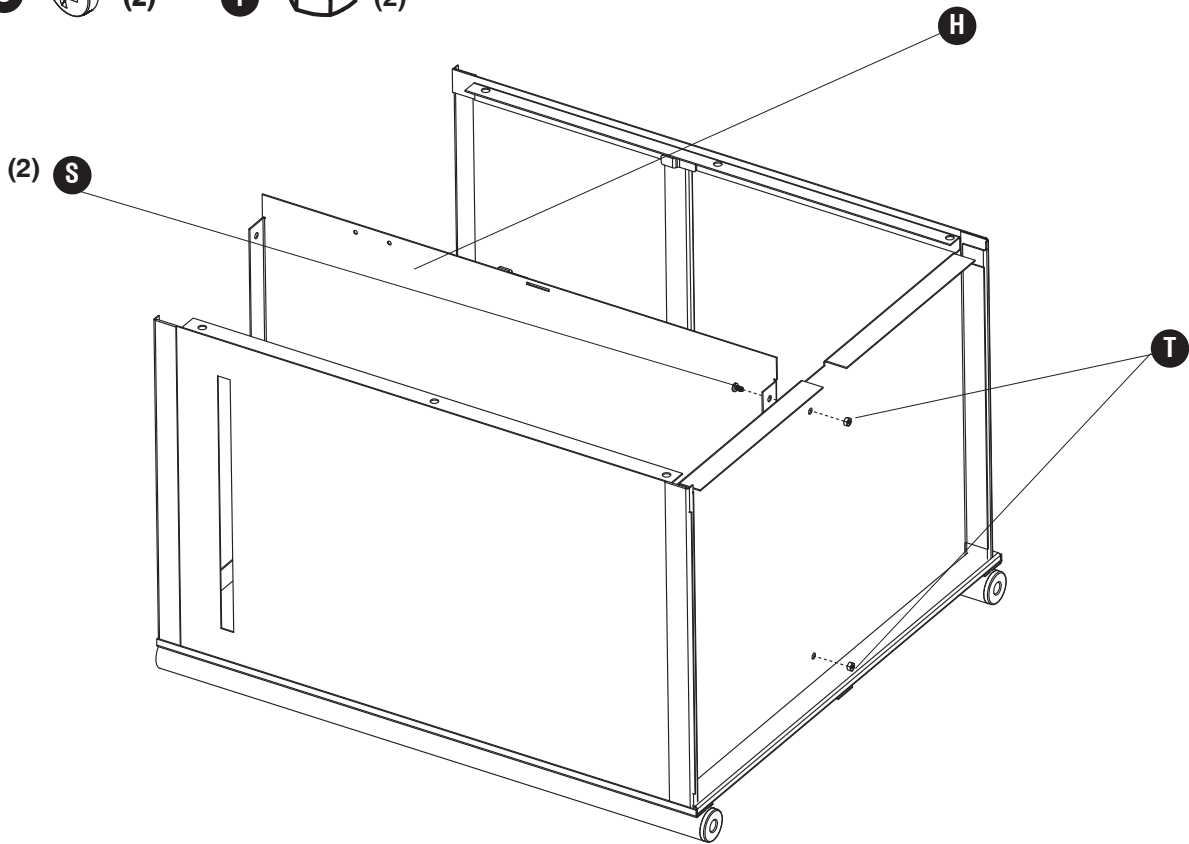

5

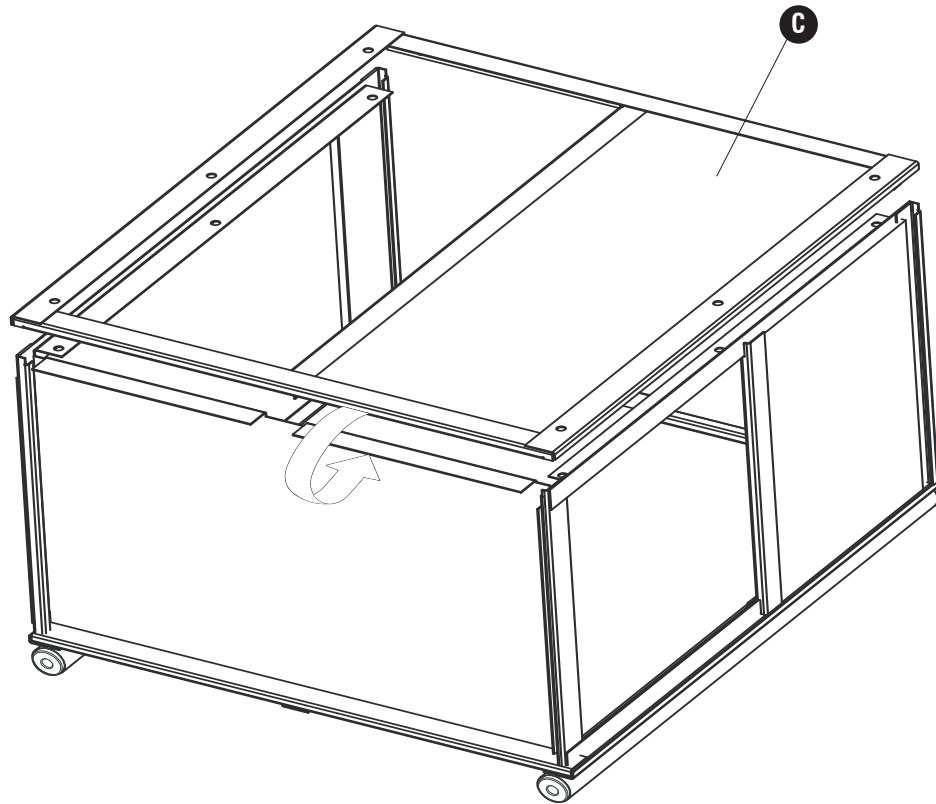

6 **N**  (3)

Insert screws only 2/3 of length
Insérer les vis à seulement 2 / 3 de la longueur
Inserte los tornillos sólo 2 / 3 de la longitud

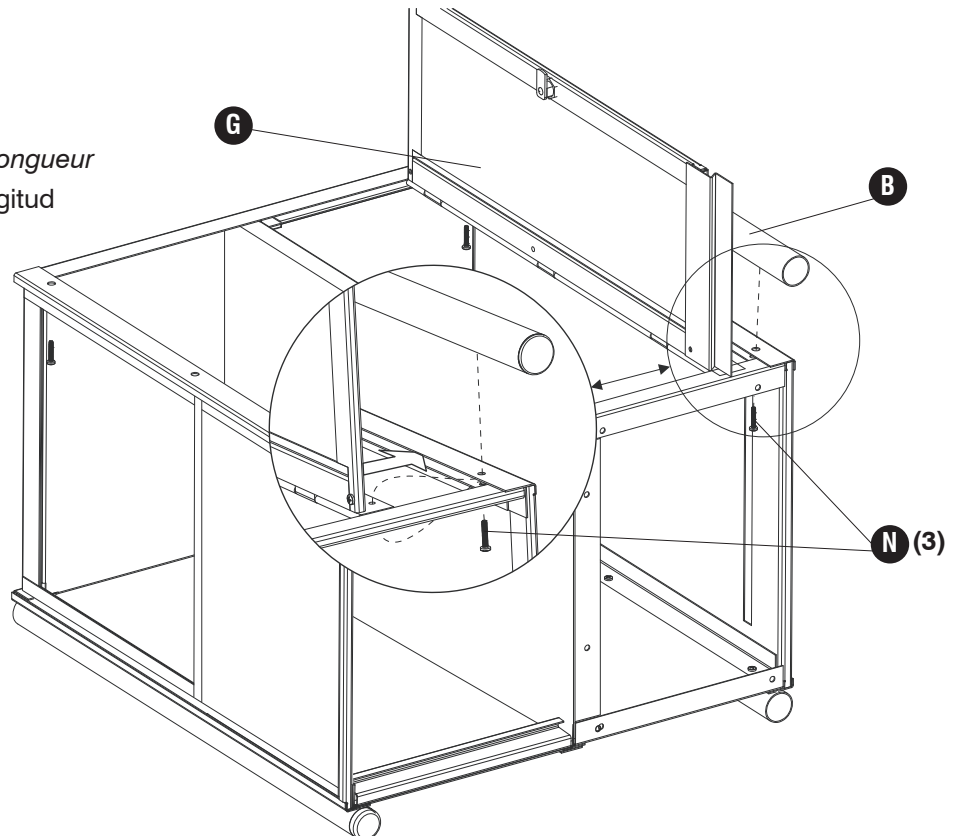

Place the door hinge between the side panel and front frame.
Place de la charnière de porte entre le panneau latéral et frontal cadre.
Coloque la bisagra de la puerta entre el panel lateral y frontal marco.

7 **N**  (3)

Tighten all screws
Serrez toutes les vis
Apriete todos los tornillos

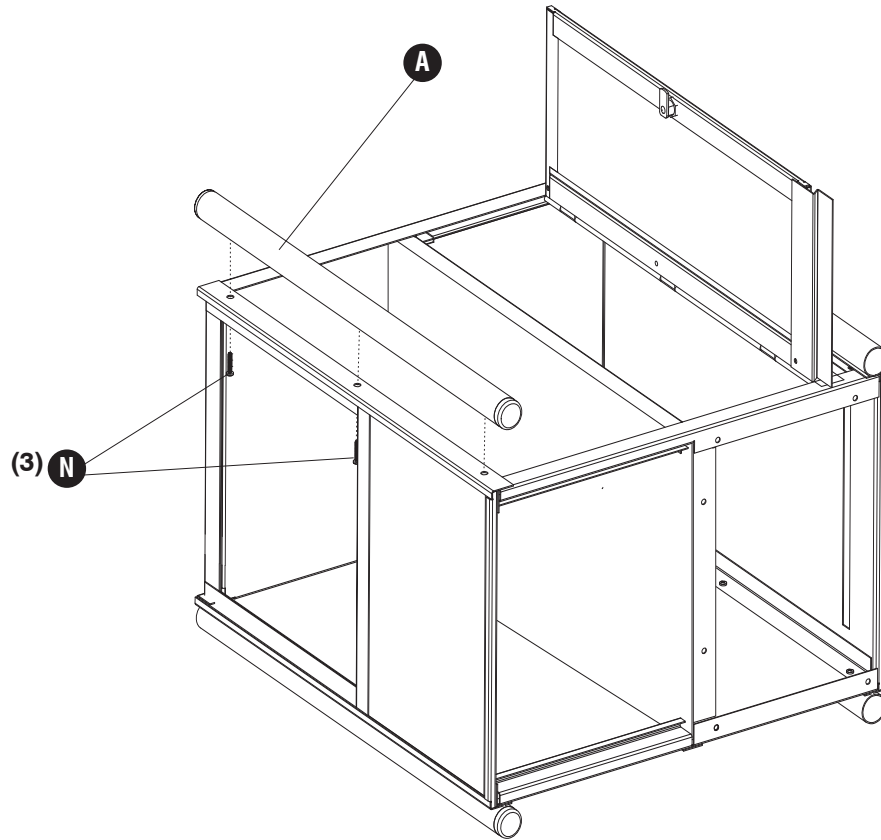

If necessary, Close door and adjust for proper alignment, then tighten all door screws

Si nécessaire, Fermez les porte et ajuster jusqu'à ce que l'alignement est correct, puis serrez toutes les vis de la porte

Si es necesario, Cierre las puerta y ajustar la alineación adecuada, a continuación, apriete todos los tornillos de las puertas

8 **Q**  **V**  (2) **W**  (2)

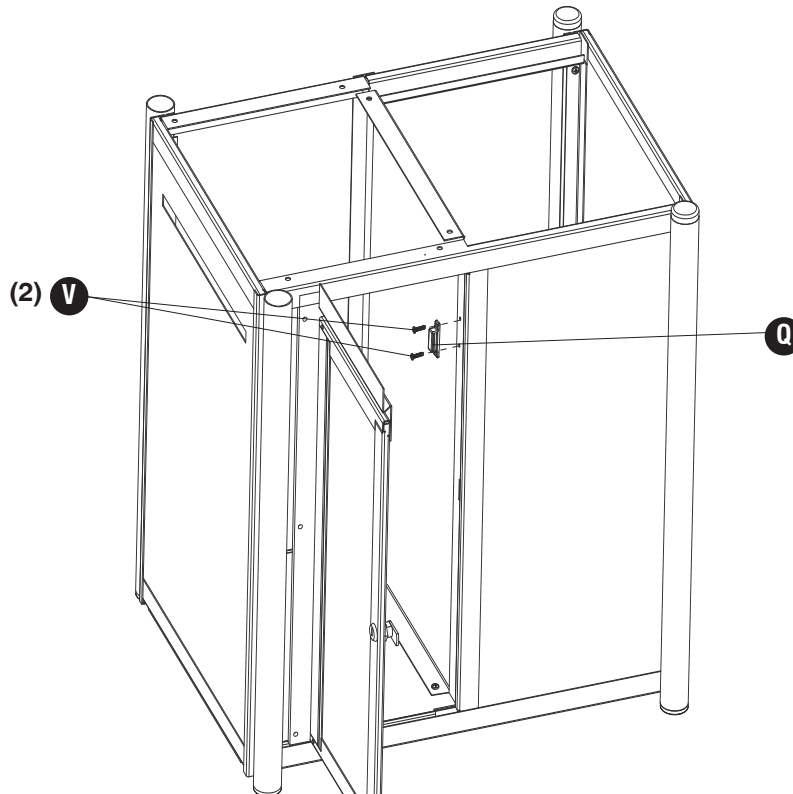

9 0  (6)

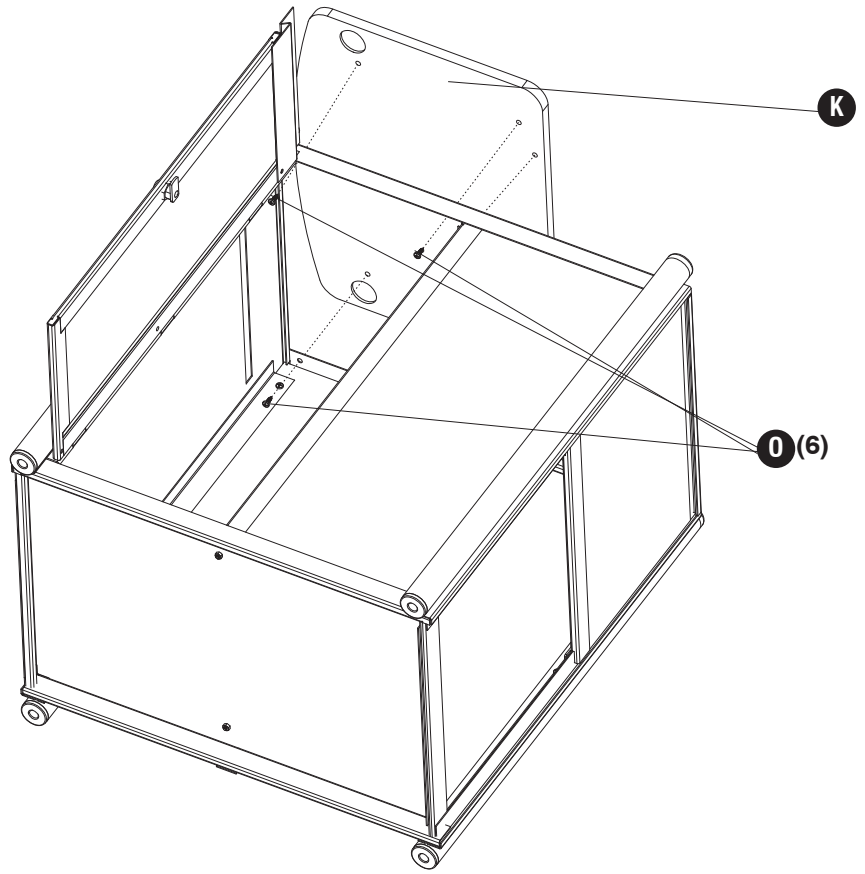

10 X  (2) Y  (2)

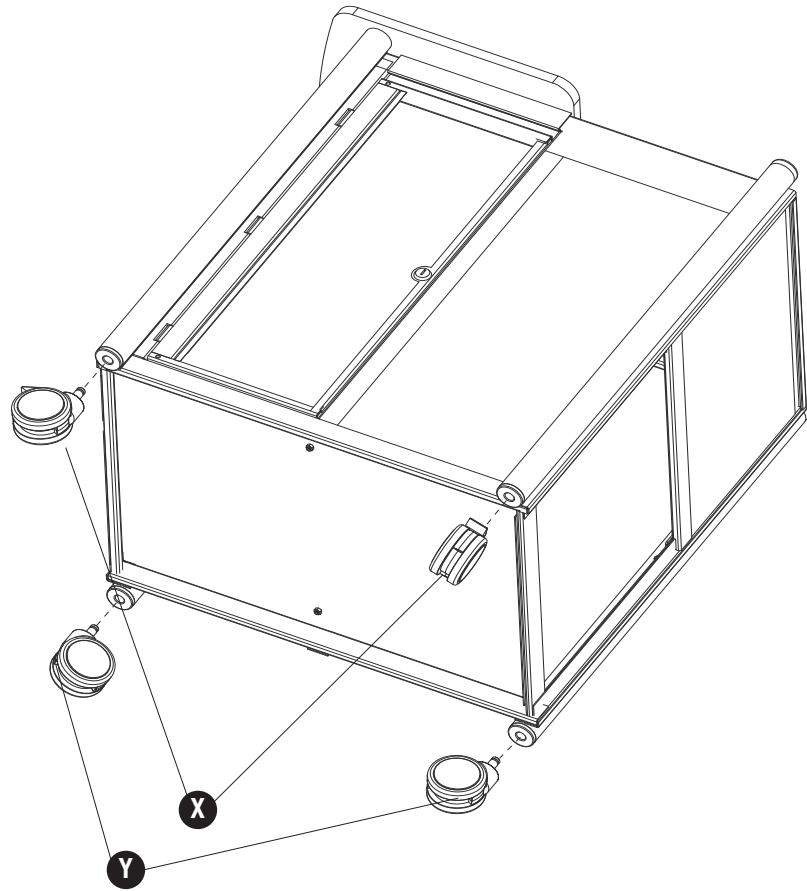

11

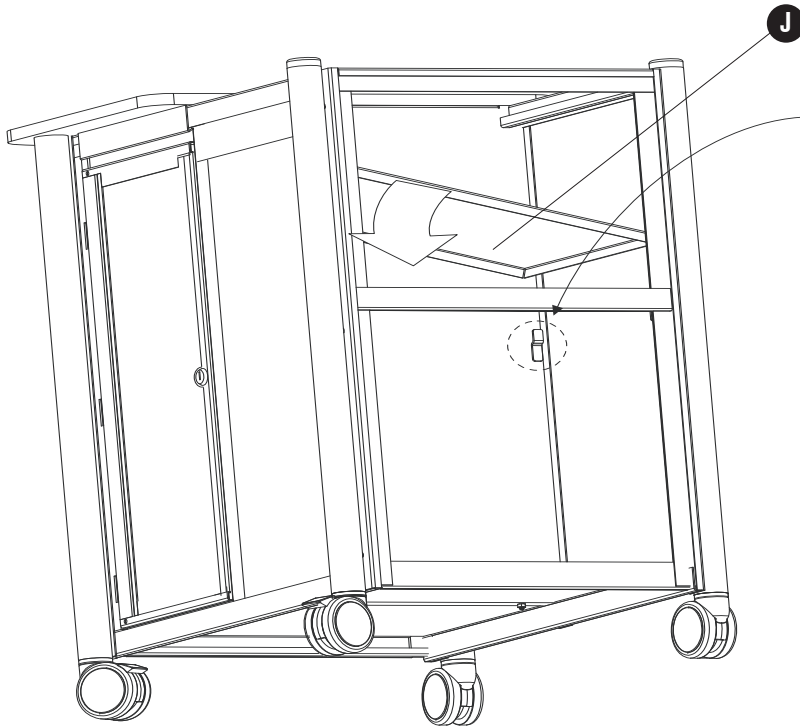

Engage all four supports
S'enclencher tous les quatre supports
Intertraba de los cuatro soportes

12 U

