

ASSEMBLY INSTRUCTIONS

INSTRUCTIONS DE MONTAGE

INSTRUCCIONES DE ENSAMBLAJE

9444

**Après™ Single Door with
Open Shelves**

*Après™ Seul porte avec
ouvert étagères*

**Après™ Puerta único con
estantes abierto**

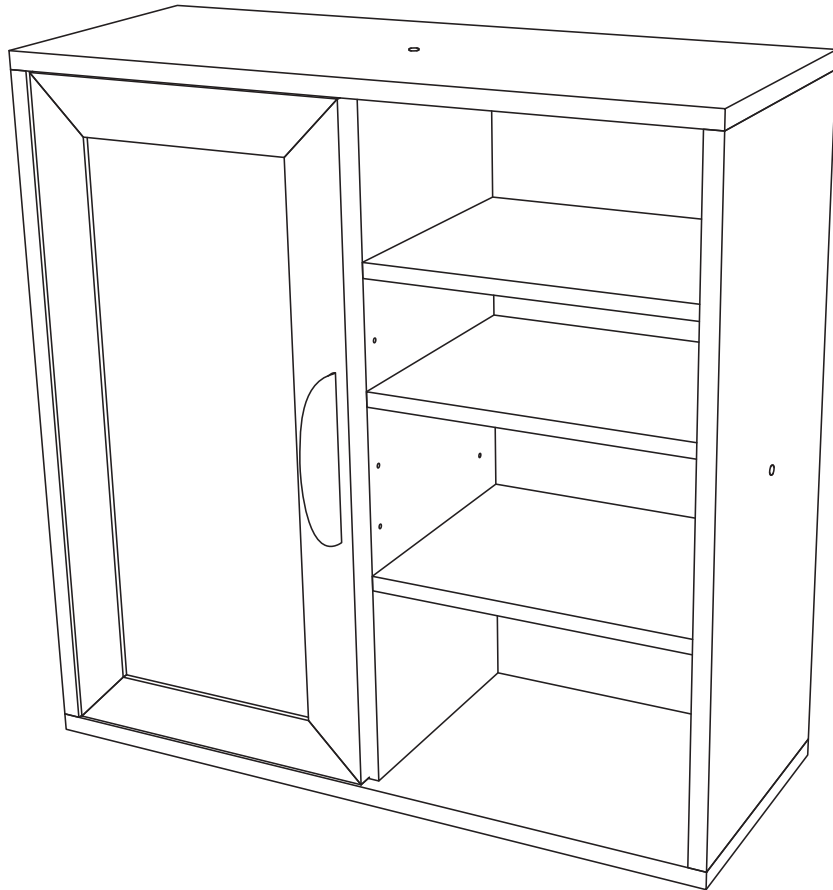

PRODUCT WARRANTY REGISTRATION is available online at: www.safcoproducts.com

• L'INSCRIPTION POUR LA GARANTIE DU PRODUIT est disponible sur l'Internet : www.safcoproducts.com

• EI REGISTRO PARA LA GARANTÍA DEL PRODUCTO está disponible en la Internet: www.safcoproducts.com

For questions or concerns, please call **1-800-664-0042**
available Monday-Friday 7:00 AM to 6:00 PM (Central Time) (English-speaking operators)

Si vous avez des questions pour poser ou les préoccupations pour exprimer, connecter **au 1-800-664-0042**
de 7H00 à 18H00 (Heure centrale) (Opérateurs de langue anglaise)

Si usted tiene preguntas o preocupaciones, por favor llame **1-800-664-0042**
de 7:00 AM a 6:00 PM (Hora Central) (Operadores que hablan inglés)

TOOLS REQUIRED: Flat-bladed Screwdriver; Phillips Screwdriver;
Hammer, Tape measure

PARTS LIST

CODE	DESCRIPTION	QTY	PART NO.
(A)	Top panel	2	9444-01\$
(B)	Left side panel	1	9442-02\$
(C)	Right side panel	1	9444-06\$
(D)	Vertical partition	1	9444-03\$
(E)	Door	1	9442-04\$
(F)	Shelf	5	9444-05\$
(G)	Back panel	1	9445-09\$

§Note: When corresponding about parts, be sure to state color: Mahogany (MH), or Cherry (CY).

OUTILS REQUIS : Tournevis plat à lame ; tournevis à pointe cruciforme ; marteau; Mètre à ruban

LISTE DES PIÈCES

CODE	DESCRIPTION	QUANTITÉ	N° DE PIÈCE
(A)	Panneau supérieur	2	9444-01\$
(B)	Panneau côté gauche	1	9442-02\$
(C)	Panneau côté droit	1	9444-06\$
(D)	Panneau verticale	1	9444-03\$
(E)	Porte	1	9442-04\$
(F)	Étagère	5	9444-05\$
(G)	Panneau arrière	1	9445-09\$

§ Note: Quand correspondre au sujet de parties, soyez sûr d'affirmer la couleur: Acajou (MH) ou Cerise (CY).















HERRAMIENTAS REQUERIDAS: Piso aspas destornillador; destornillador Phillips; martillo; Cinta métrica

LISTA DE PIEZAS





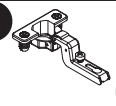









CODIGO	DESCRIPCIÓN	CANTIDAD	NO. DE PIEZA
(A)	Panel superior	2	9442-01\$
(B)	Panel lateral izquierdo	1	9442-02\$
(C)	Panel lateral derecho	1	9444-06\$
(D)	Partició vertical	1	9444-03\$
(E)	Puerta	1	9442-04\$
(F)	Estante	5	9444-05\$
(G)	Panel trasero	1	9445-09\$

§ Note: Al corresponder sobre las piezas, esté seguro declarar el color: Caoba (MH) o Cereza (CY).

HARDWARE PACK 9444-19\$

H  Locking Cam Qty.: 8 #HFFMFC	I  Screw Post Qty.: 8 #HFFMFB	J  Shelf Peg Qty.: 20 #HSFBNZ
K  Nail Qty.: 20 #FNAIL	L  Female Connector Screw Qty.: 2 #5340-28NC	M  Male Connector Screw Qty.: 2 #5340-29NC
N  Wood Dowel Qty.: 12 #H8MMDWL	O  Wood Screw Hole Cover Qty.: 4 #9440-10\$	P  Hinge Mount Qty.: 2 #8953-14
R  Handle Qty.: 1 #8962-31	S  Screw Qty.: 2 #1850-23	T  Strip of 4 bumpers Qty.: 1 #9355-11nc
	Q  Hinge Qty.: 2 #8953-16	U  Connector pin Qty.: 2 #9444-02NC

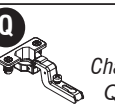
Paquet matériel 9444-19\$

H  Cam Qté.: 8 #HFFMFC	I  Poteau avec la fin d'un vis Qté.: 8 #HFFMFB	J  Épingle du glissement Qté.: 20 #HSFBNZ
K  Clous Qté.: 20 #FNAIL	L  Vis pour se relier (femelle) Qté.: 2 #5340-28NC	M  Vis pour se relier (mâle) Qté.: 2 #5340-29NC
N  Piquet de bois Qté.: 12 #H8MMDWL	O  Bois pour la Couverture Trou Qté.: 4 #9440-10\$	P  Support de la charnière Qté.: 2 #8953-14
R  Poignée Qté.: 1 #8962-31	S  Vis Qté.: 2 #8150-23	T  Bande de 4 butoirs Qté.: 1 #9355-11NC
	Q  Charnière Qté.: 2 #8953-16	U  Goupille du connecteur Qty.: 2 #9444-02NC

Paquete material 9444-19\$

H  Leva del freno Cant.: 8 #HFFMFC	I  Poste con el tornillo-extremo Cant.: 8 #HFFMFB	J  Clavija del estante Cant.: 20 #HSFBNZ
K  Punta de Paris Cant.: 20 #FNAIL	L  Tornillo para conectar (hembra) Cant.: 2 #5340-28NC	M  Tornillo para conectar (varón) Cant.: 2 #5340-29NC
N  Clavijas de madera Cant.: 12 #H8MMDWL	O  madera para cubrir el agujero Cant.: 4 #9440-10\$	P  Apoyo de la charnela Cant.: 2 #8953-14
R  Manche Cant.: 1 #8962-31	S  Tornillo Cant.: 2 #8150-23	T  Tira de 4 parachoques Cant.: 1 #9355-11NC
	Q  Charnela Cant.: 2 #8953-16	U  Conector clavija Qty.: 2 #9444-02NC

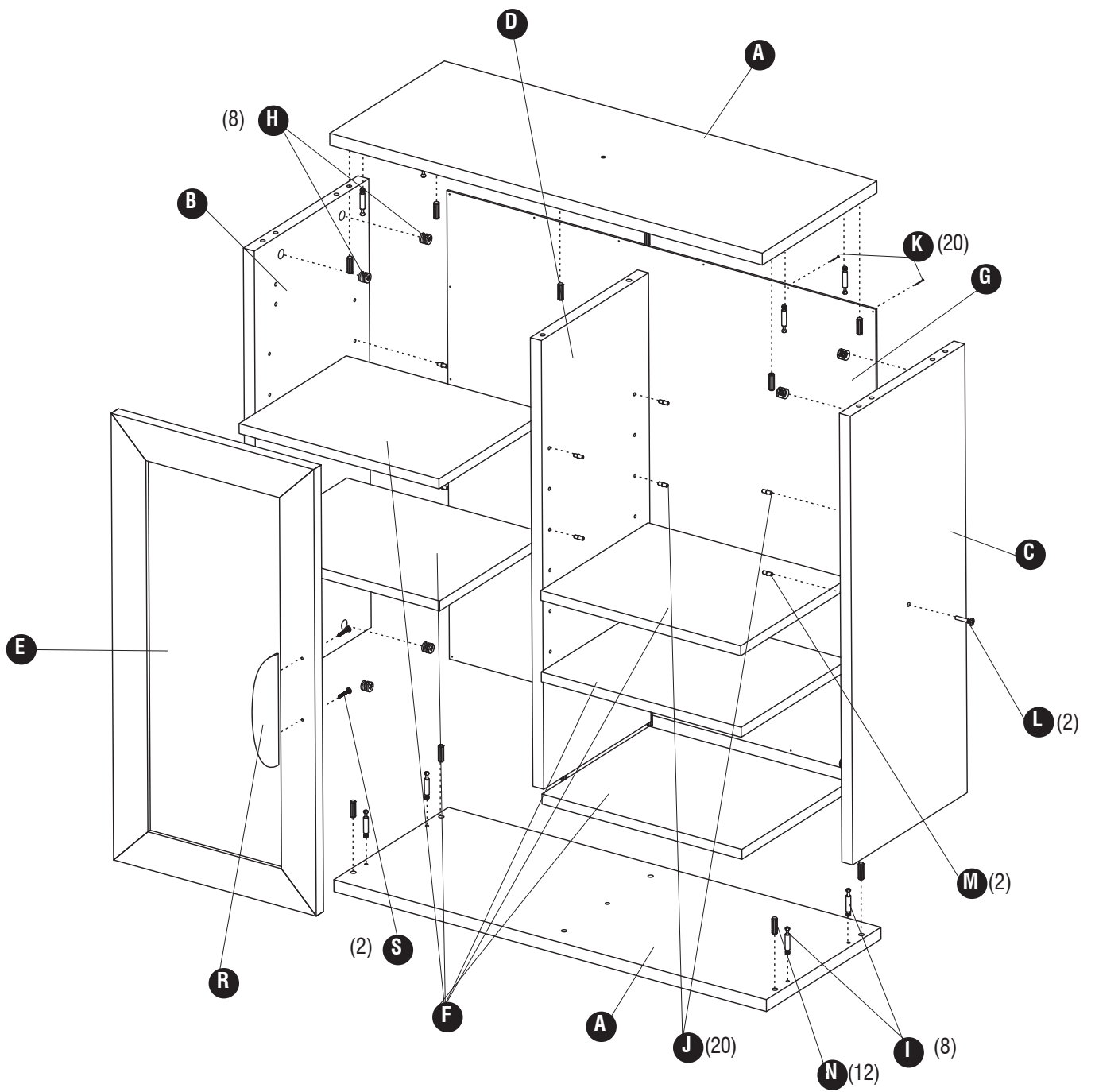

1

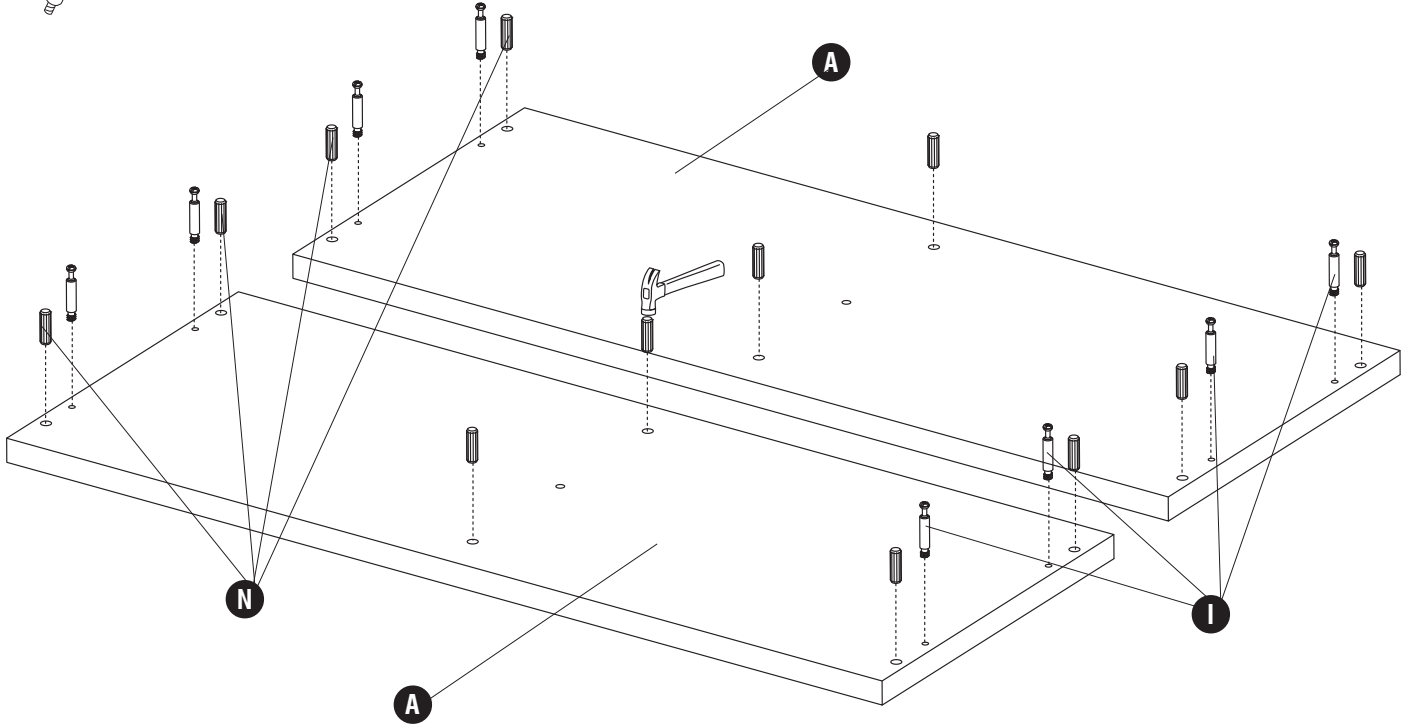
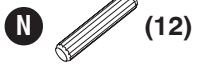
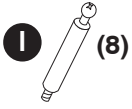

2



Arrow points to hole on edge
Flèche pointe vers le trou sur le côté
 La flecha indica el agujero en el borde

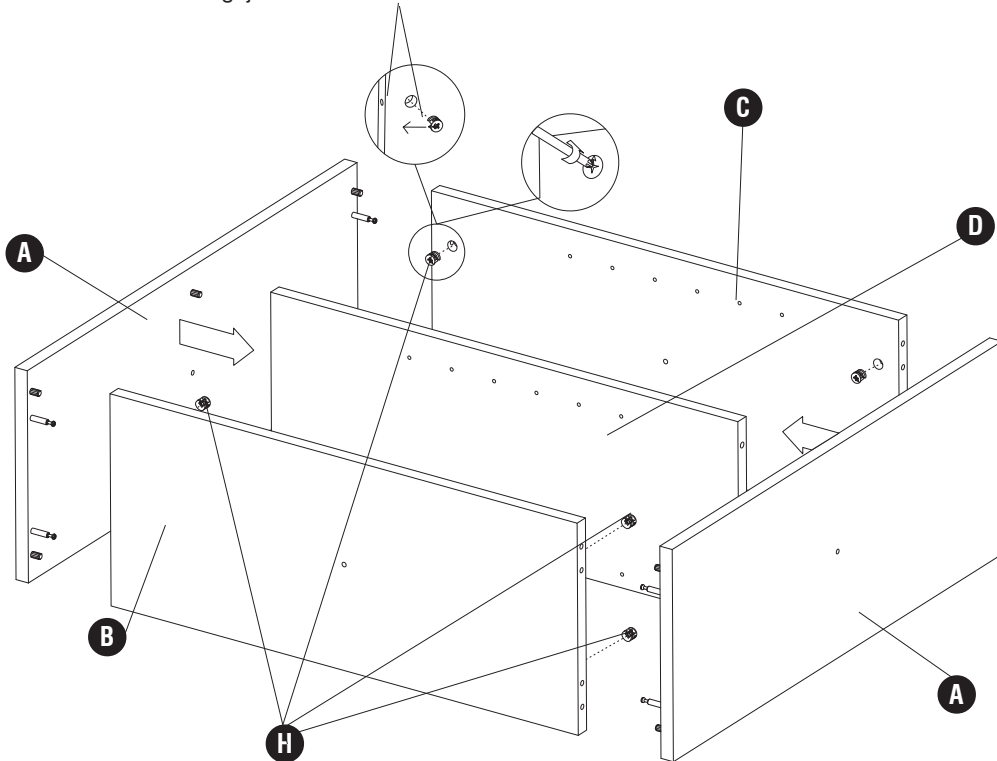

3 **K** (20)

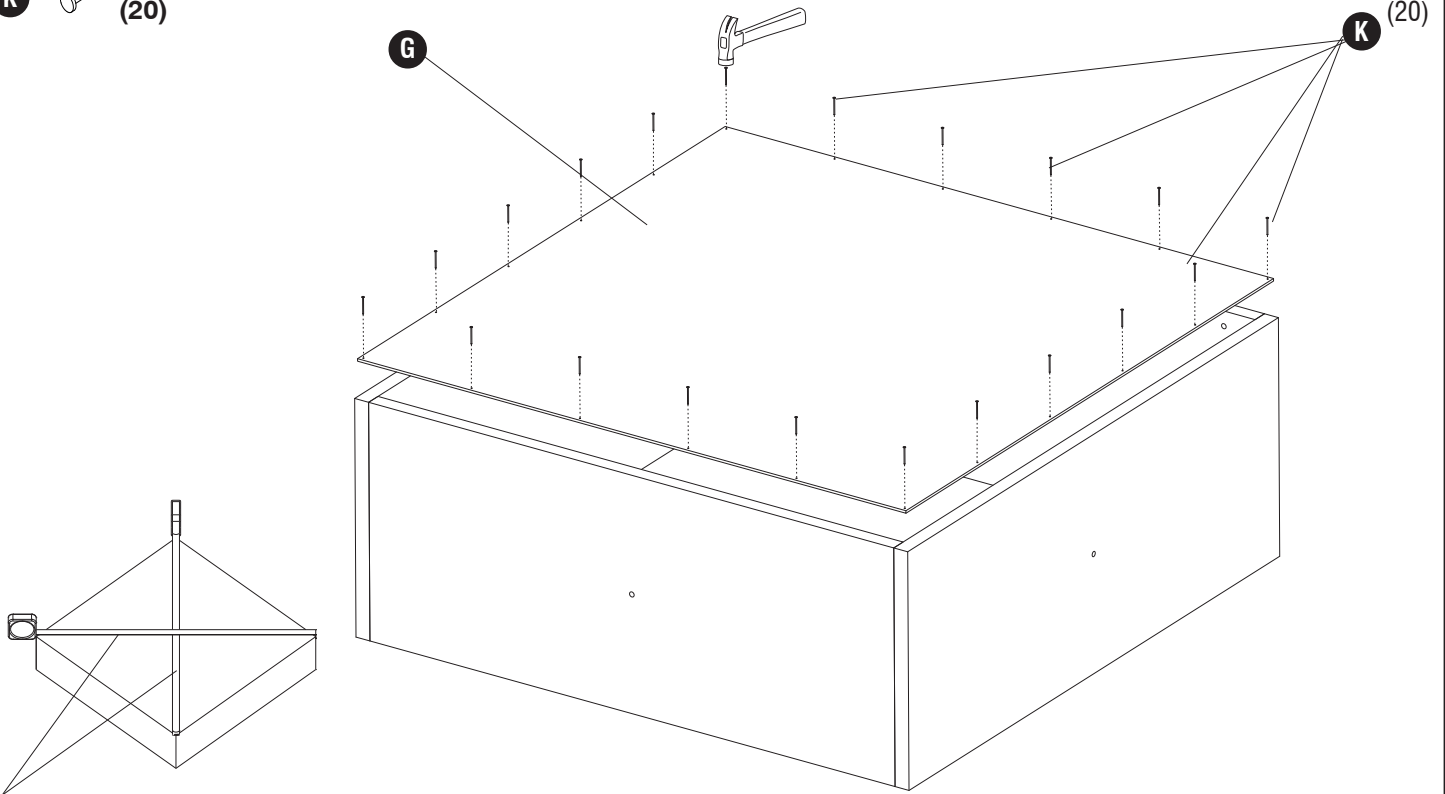

IMPORTANT: Must be equal to be square.
ATTENTION: Si l'égalité, puis l'unité est d'équerre.
IMPORTANTE: Debe ser igual al cuadrado.

4 **P** (2)

Q (2)

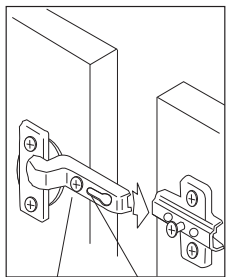

ARM
LE BRAS
EL BRAZO

SLOT
LA FENTE
LA RANURA

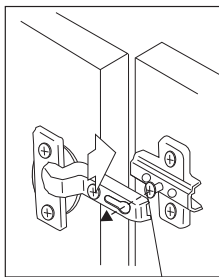

SET SCREW
Le vis
d'arrêt
El tornillo de
sujeción

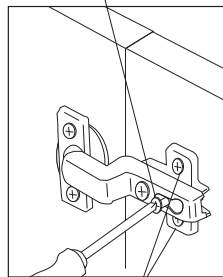

TIGHTEN SET SCREW
Serrez le vis d'arrêt
*Aprete el tornillo de
sujeción*

VERTICAL ADJUSTMENT
Ajustement vertical
Ajuste vertical

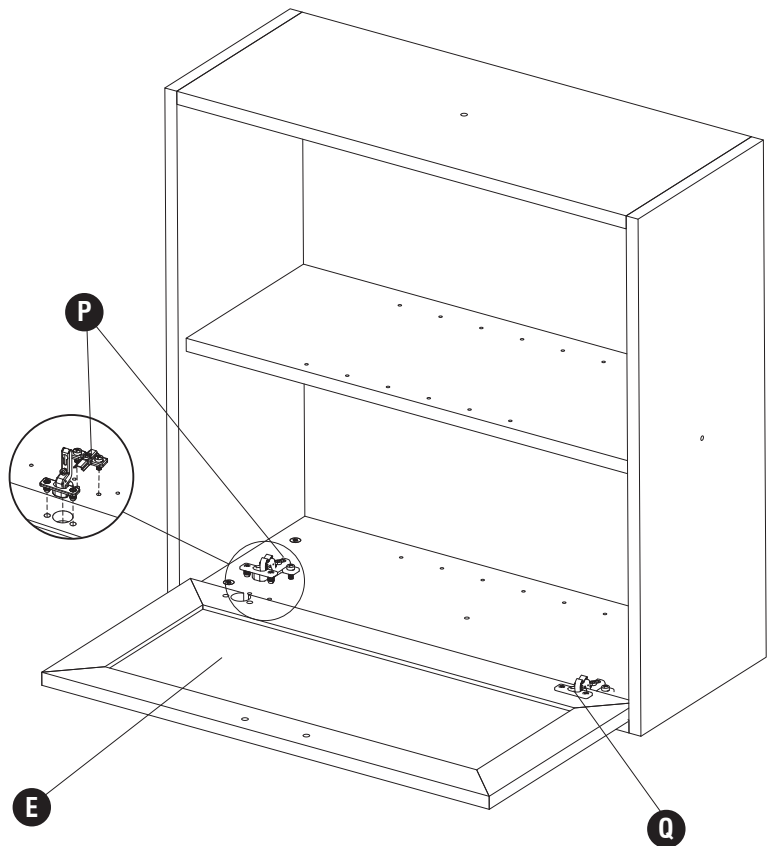

5 **R** (1) **S** (2)

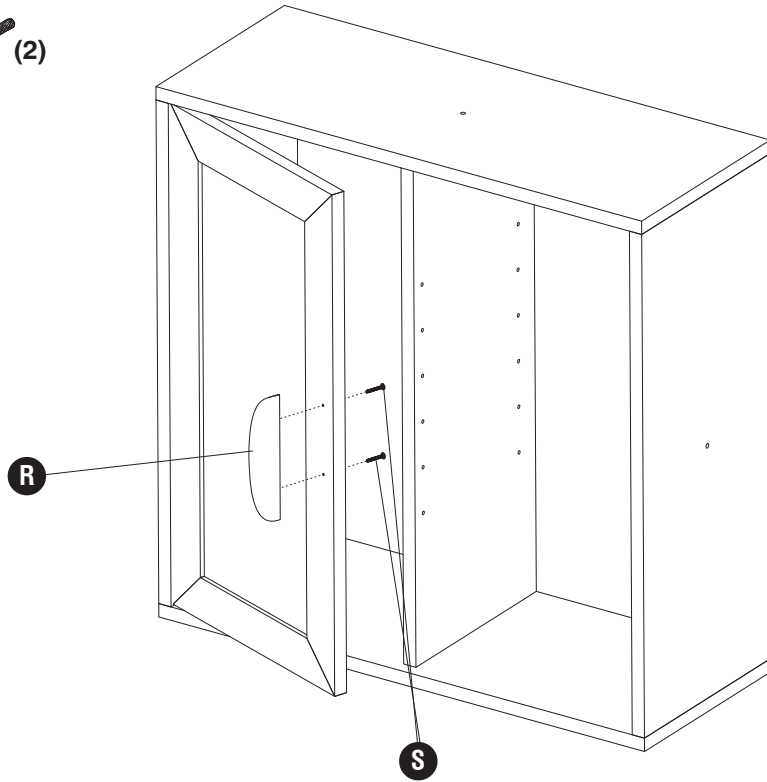

6 **J** (20)

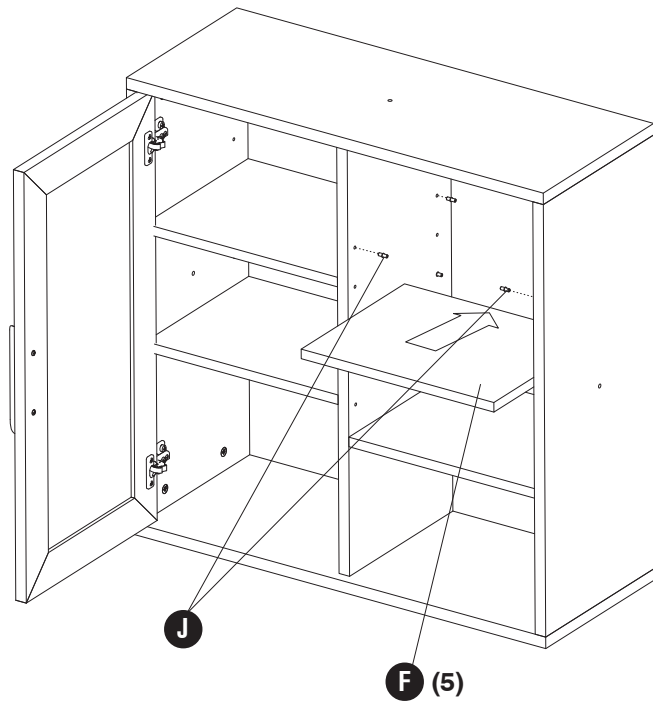

7 **L** (2) **M** (2) **U** (2) **O** (4)

Note: When Connecting this unit to the top of units 9440, 9441, 9442, and 9445, push connector pin through the top of the bottom unit and secure with a hole cover.

Note: Lorsque le placement de cette unité au-dessus d'unités, 9440, 9441, 9442 et 9445, Les broches du connecteur doit être poussée par le haut du bas appareil. La broche est suspendue avec 9440-10.

Note: Cuando conecte esta unidad a la parte superior de las unidades 9440, 9441, 9442 y 9445, mantenga en su lugar empujando el conector a través de la clavija de la parte superior de la unidad de fondo se mantuvo firme y con un agujero de portada

Note: for connecting adjacent units only; use cap on exposed holes.

Note: pour relier les unités adjacentes seulement; le utiliser couvercle sur exposé trou.

Note: para conectar unidades adyacentes solamente; uso madera tapon para cubrir el agujero