

ASSEMBLY INSTRUCTIONS INSTRUCTIONS DE MONTAGE INSTRUCCIONES DE ENSAMBLAJE

7749

Sorting Table, Base with Shelf

Table de Tri, Base avec Étagère

Mesa Clasificando, la Base con el Estante

Top Sold Separately

Haut vendu séparément

Parte superior se vende por separado

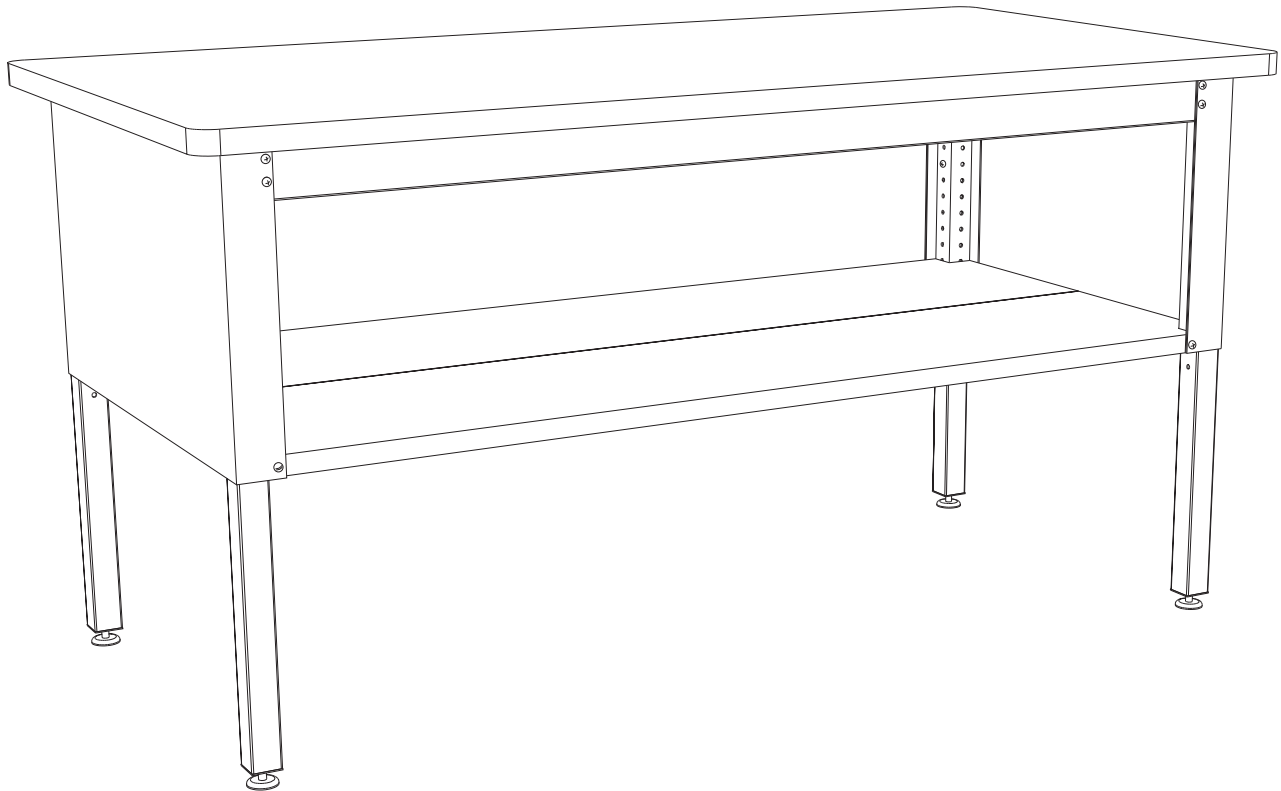

PRODUCT WARRANTY REGISTRATION is available online at: www.safcoproducts.com

• L'INSCRIPTION POUR LA GARANTIE DU PRODUIT est disponible sur l'Internet : www.safcoproducts.com

• EI REGISTRO PARA LA GARANTÍA DEL PRODUCTO está disponible en la Internet: www.safcoproducts.com

For questions or concerns, please call **1-800-664-0042**
available Monday-Friday 7:00 AM to 6:00 PM (Central Time) (English-speaking operators)

Si vous avez des questions pour poser ou les préoccupations pour exprimer, connecter **au 1-800-664-0042** de 7H00 à 18H00 (Heure centrale) (Opérateurs de langue anglaise)

Si usted tiene preguntas o preocupaciones, por favor llame **1-800-664-0042** de 7:00 AM a 6:00 PM (Hora Central) (Operadores que hablan inglés)

TOOLS REQUIRED: Phillips Screwdriver, Adjustable Wrench
OUTILS REQUIS : *Tournevis à pointe cruciforme, Clef Réglable*
HERRAMIENTAS REQUERIDAS: Destornillador Phillips, Llave Ajustable

Two People Recommended.

On recommande que l'assemblage soit effectué par deux personnes.

Se recomienda dos personas para el ensamblaje.

Parts List / Liste des Pièces / Lista de Piezas			
Code/ Código	DESCRIPTION / DESCRIPTION / DESCRIPCIÓN	Qty./ Qté/ Cant.	Part No./ N° de Pièce / No. de Pieza
(A)	Back Panel / Panneau arrière / Tablero trasero	1	7749-01§
(B)	Side Panel, Left / Panneau latéral, gauche / Panel lateral, izquierda	1	7749-02§
(C)	Side Panel, Right / Panneau latéral, droit / Panel lateral, derecha	1	7749-03§
(D)	Shelf / Étagère / Estante	2	7749-06§
(E)	Cross Piece / Panneau de support avant / Panel de soporte frontal	1	7749-04§
(F)	Leg / Pied / Pata	4	7749-05§

Hardware Pack / Paquet Matériel / Paquete Material: 7749-19		
<p>G </p> <p>Long Screw <i>Longue vis</i> Tornillo largo Qty. / Qté. / Cant. 4 7749-22</p>	<p>H </p> <p>Short Screw <i>Vis courte</i> Corto tornillo Qty. / Qté. / Cant. 14 7749-28</p>	<p>I </p> <p>Hex Nut <i>Écrou hexagonal</i> Tuerca hexagonal Qty. / Qté. / Cant. 14 7749-29</p>
<p>J </p> <p>Top Screw <i>Vis pour Haut</i> Tornillo para el superficie Qty. / Qté. / Cant. 14 7749-27</p>	<p>K </p> <p>Glide Insert <i>Insérer pour Niveleur</i> Insertar para el Nivelador Qty. / Qté. / Cant. 4 7749-26</p>	<p>L </p> <p>Adjustable Glide <i>Niveleur</i> Nivelador Qty. / Qté. / Cant. 4 7749-25</p>

§ Note: When corresponding about parts, be sure to state color: Black (BL), or Gray (GR) .
 § *Noter: Quand correspondre au sujet de parties, soyez sûr d'affirmer la couleur: Noir (BL) ou Gris (GR) .*
 § Note: Al corresponder sobre las piezas, esté seguro declarar el color: Negro(BL) o Gris (GR).

Top Sold Separately
Haut vendu séparément
Parte superior se vende por separado

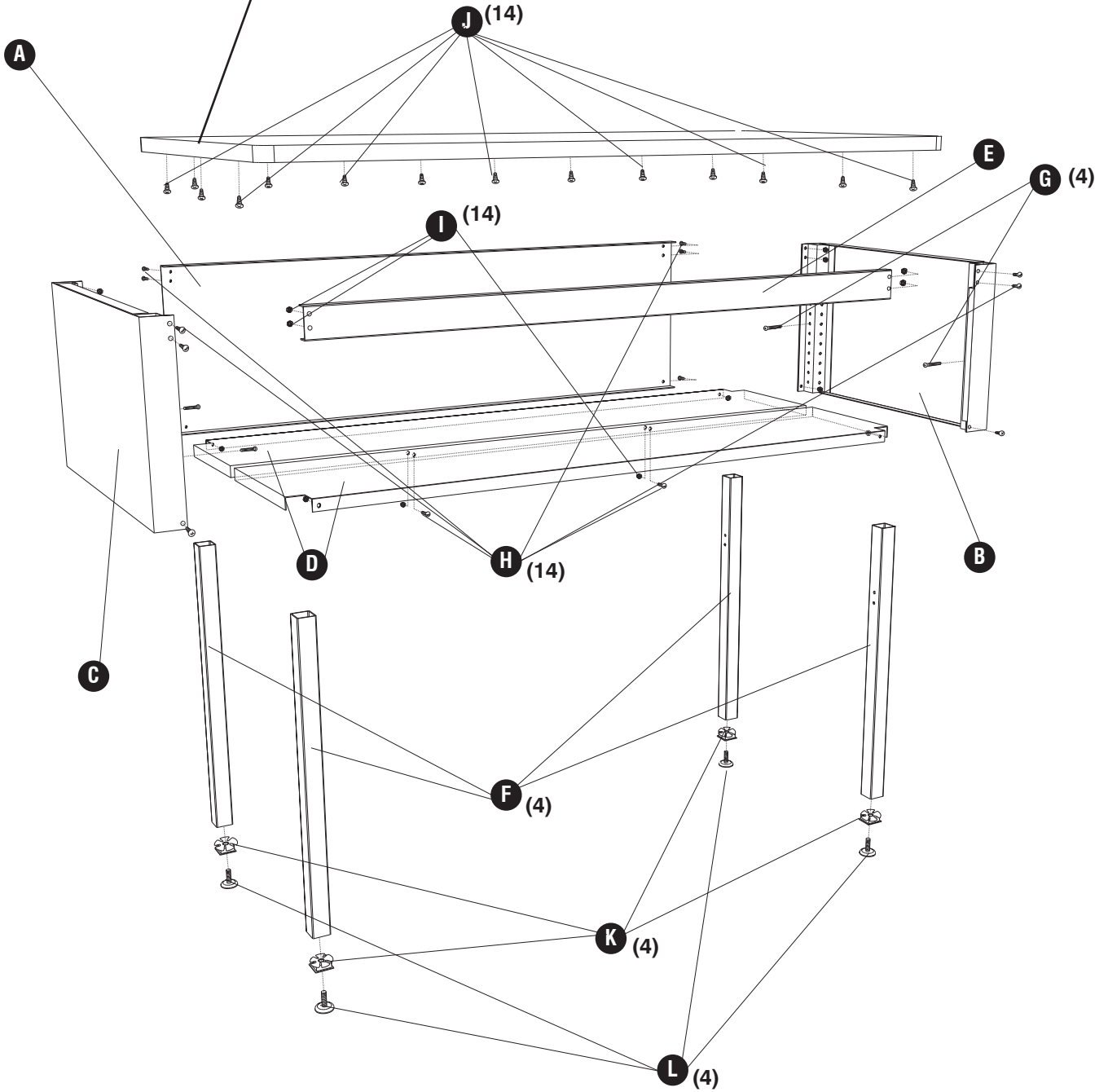

1 **J**  (14)

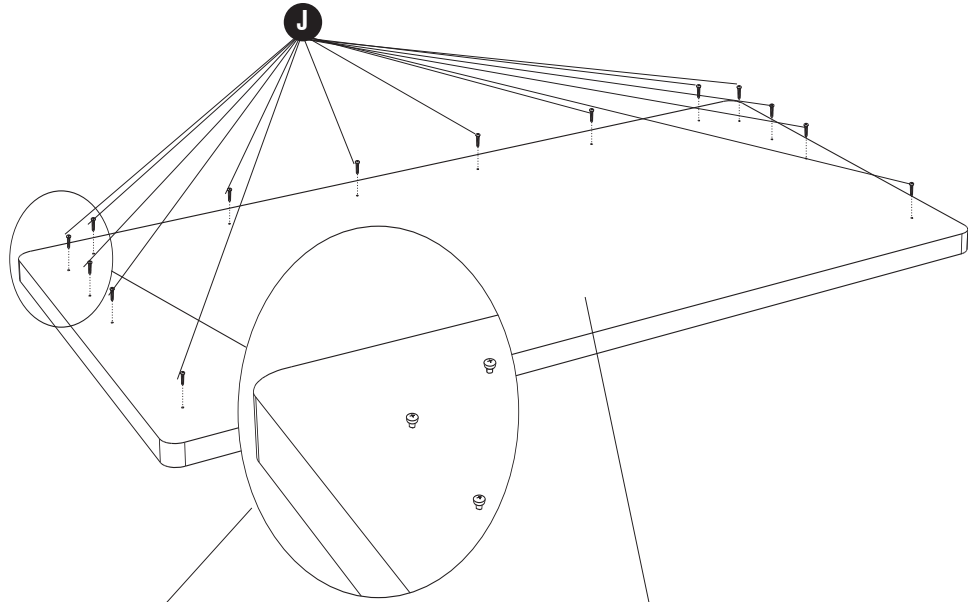

Insert screws only 2/3 of length
Insérer les vis à seulement 2 / 3 de la longueur
Inserte los tornillos sólo 2 / 3 de la longitud

Top Sold Separately
Haut vendu séparément
Parte superior se vende por separado

2

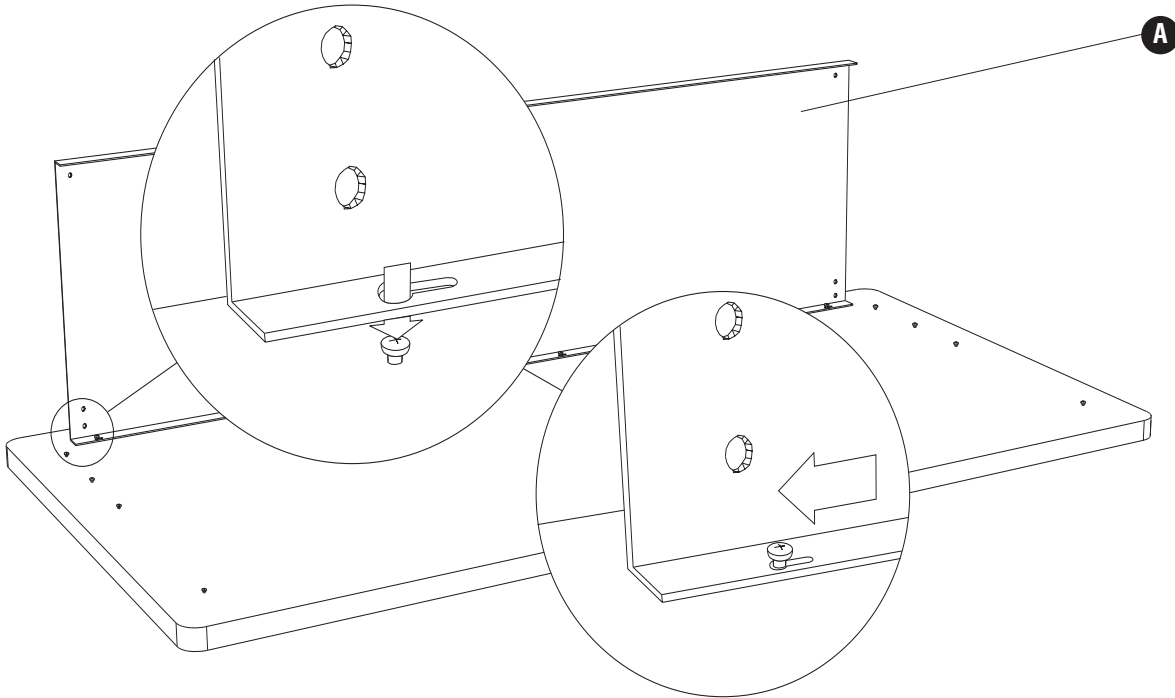

3 H (6) I (6)

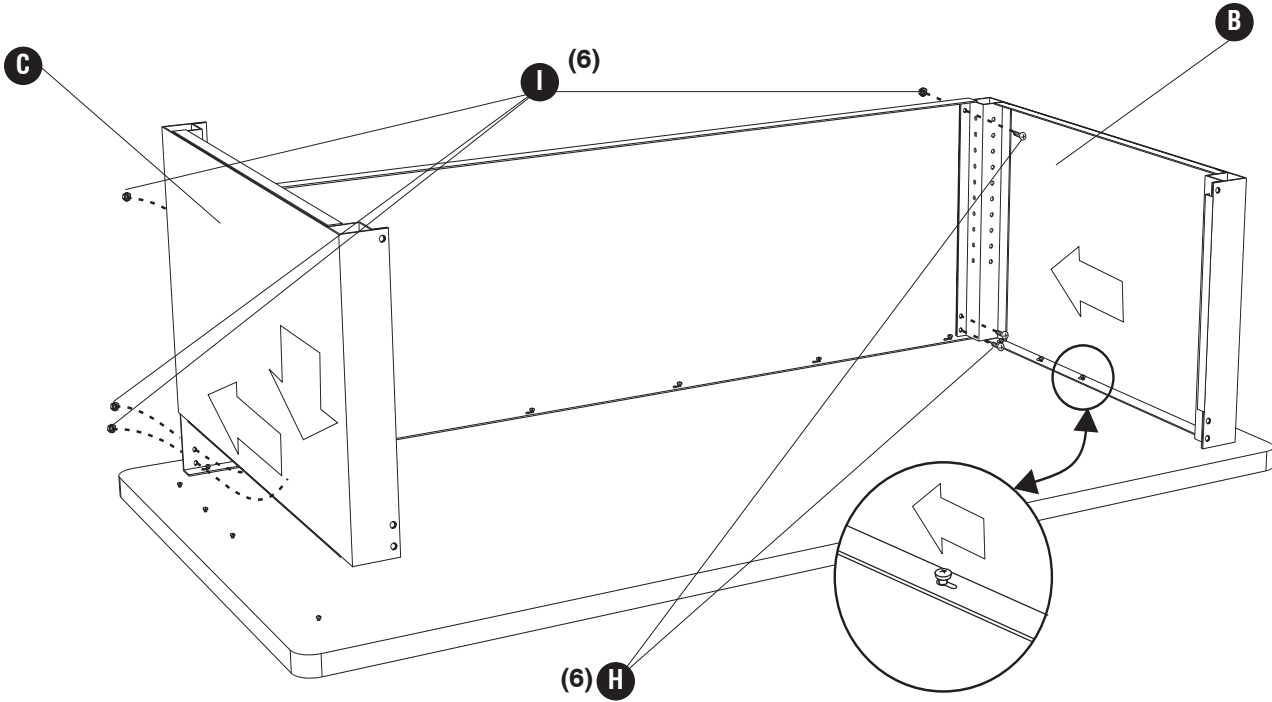

Tighten all screws
Serrez toutes les vis
Apriete todos los tornillos

4 H (4) I (4)

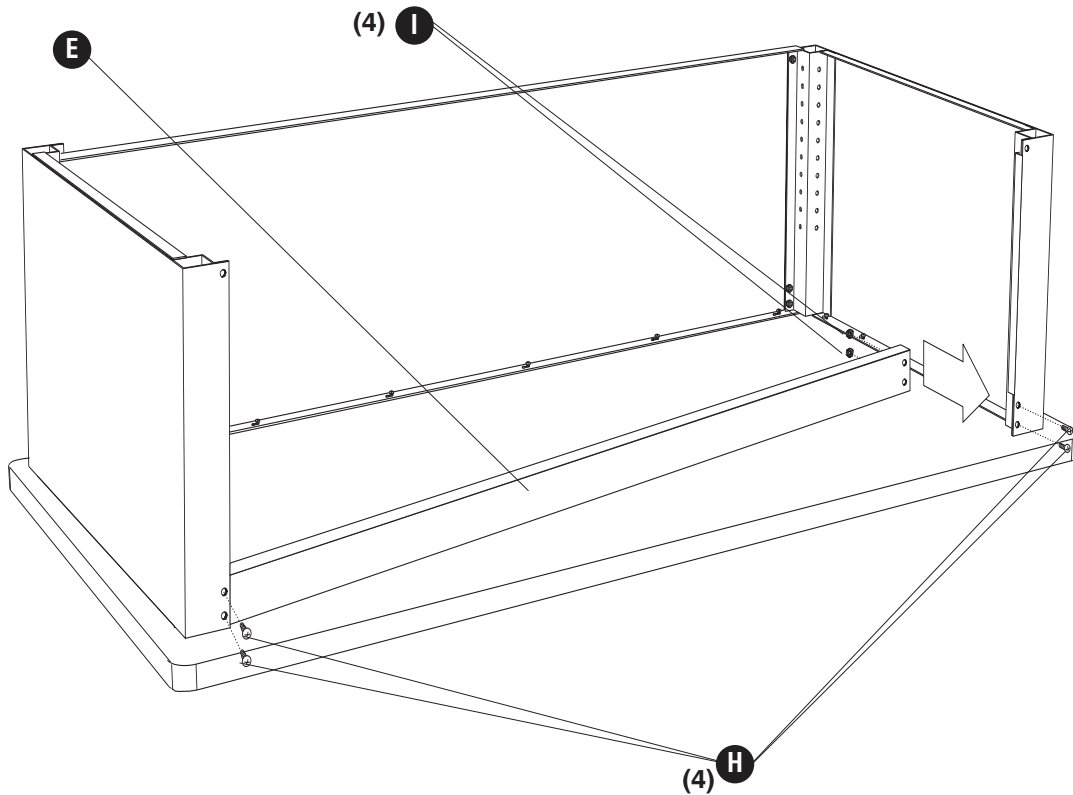

- 5** **G**  (4) **K**  (4) **L**  (4)

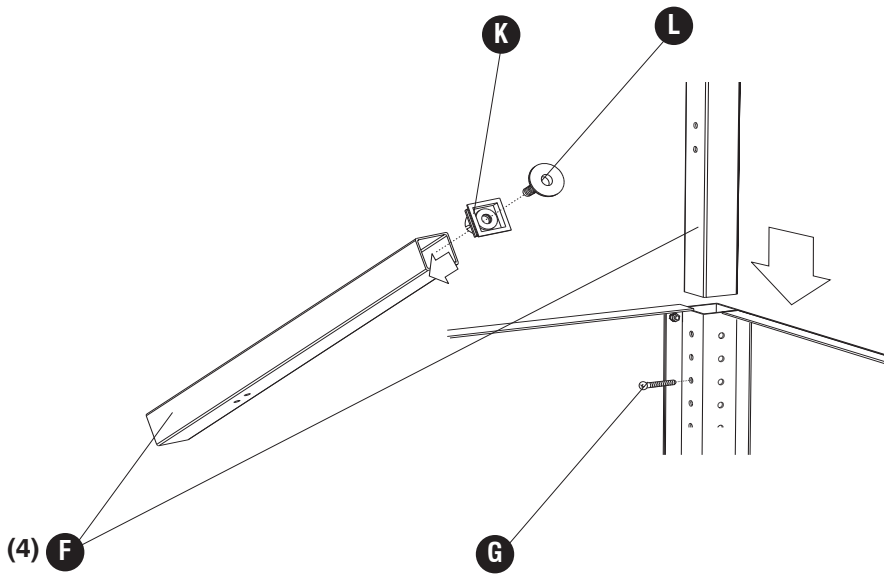

- 6** **H**  (2) **I**  (2)

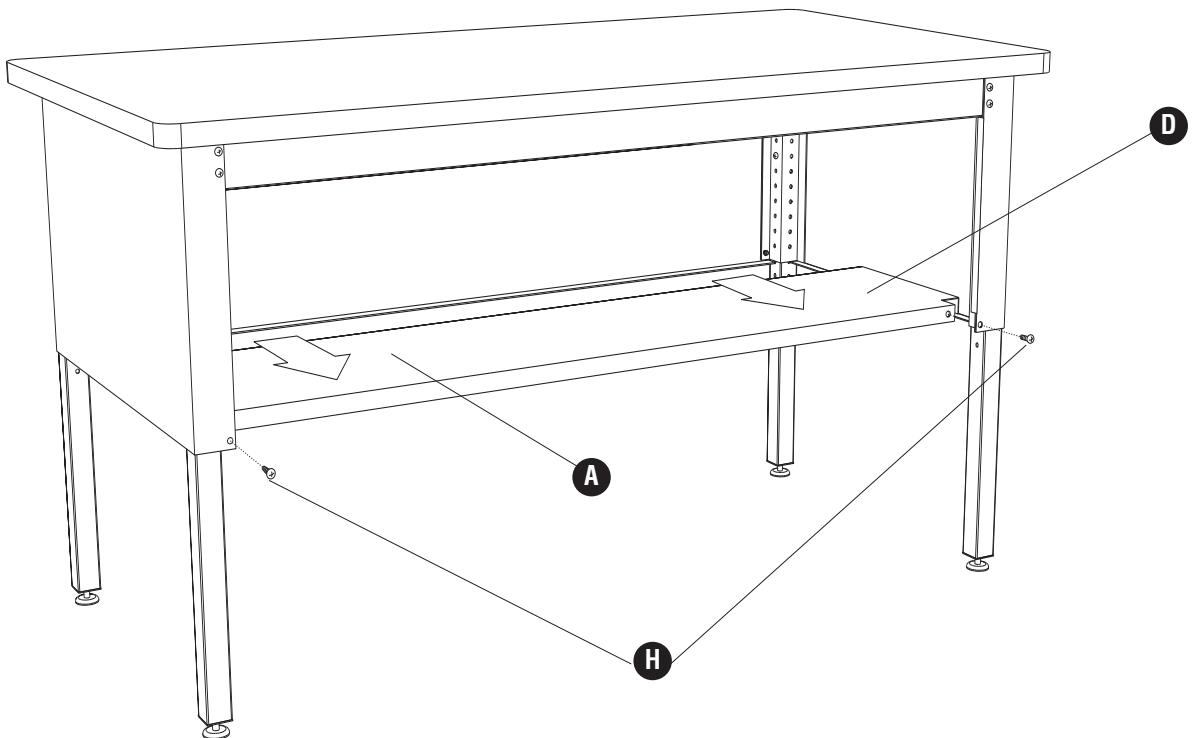

7

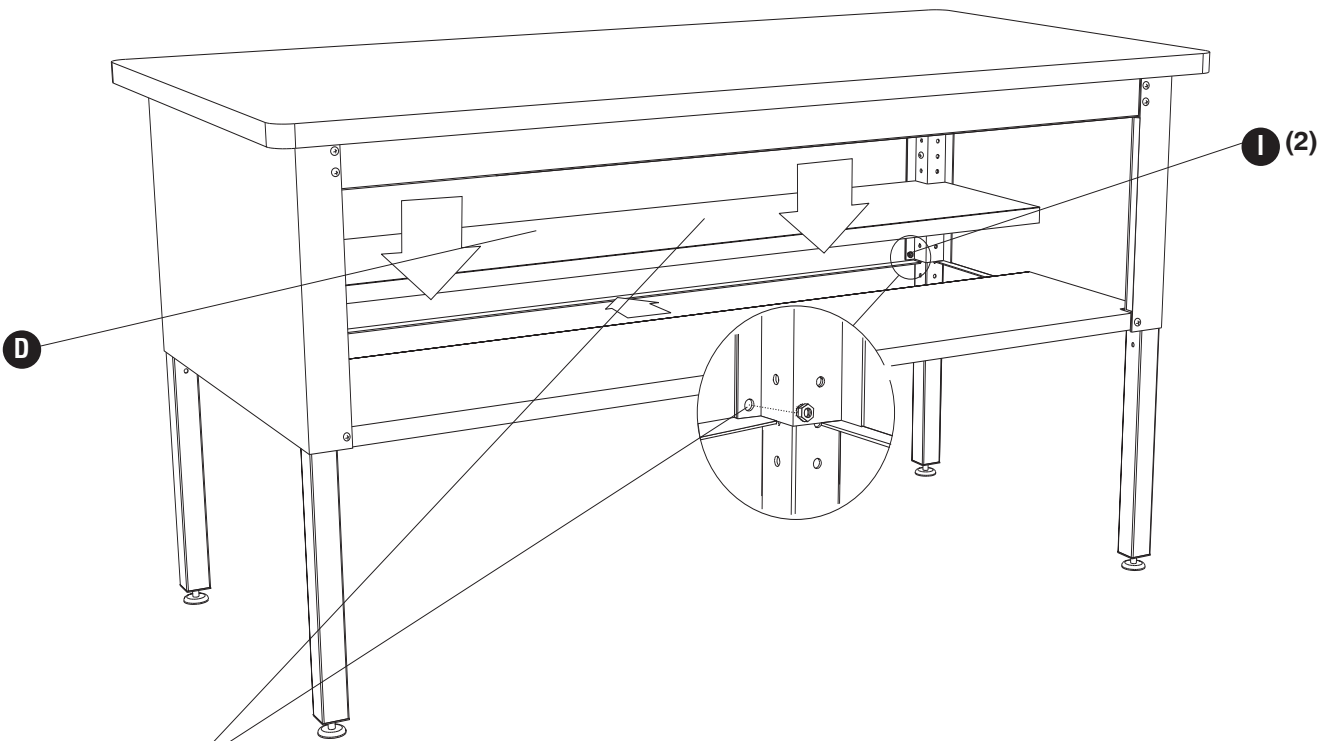

NOTE: Temporarily remove screws, place shelf then replace screws.

NOTER: Temporairement enlever les vis, placer étagère alors remplacer les vis.

NOTA: Temporalmente quitar los tornillos, la estante lugar continuación, reemplace los tornillos.

8

