

PARTS LIST			
LETTER CODE	DESCRIPTION	QTY.	PART NO.
(A)	Sorter Base	1	4146-02
(B)	Divider	6	4146-03
(C)	Single Panel Hanger	1	4152-02

Please specify color (Charcoal, Putty or Light Gray) when corresponding about parts.

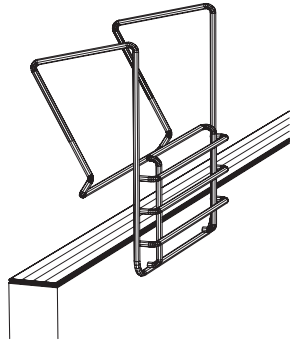
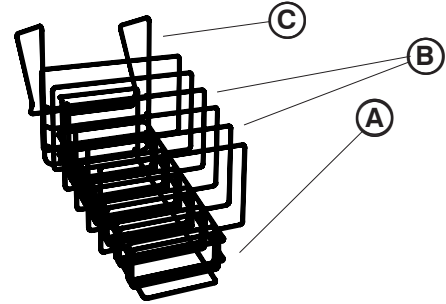

Place Single Panel Hanger over office panel, as shown at left (you may have to spread the wire hanger slightly for thicker panels, but take care not to over-bend).

Attach Sorter Base as shown at right. Note: for proper support, do not hang Sorter Base from the lowest thin wire of the hanger. Finally, slide Dividers between close-set loops in Sorter Base.

