

ASSEMBLY INSTRUCTIONS
INSTRUCCIONES DE MONTAGE
INSTRUCCIONES DE ENSAMBLAJE

7751
Sorter Module
De Tri Module
Clasificación del Módulo

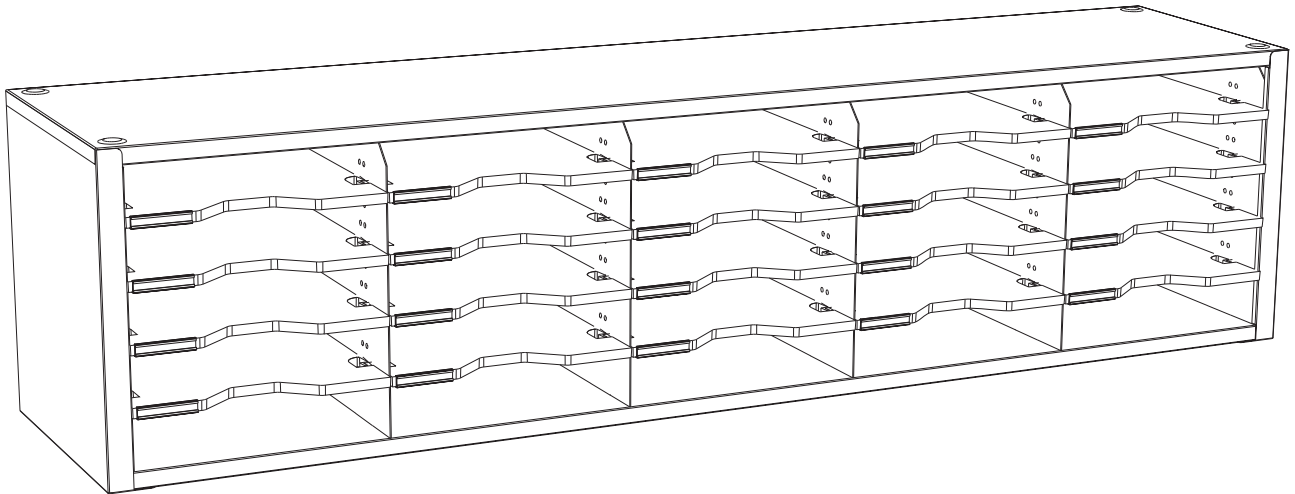

PRODUCT WARRANTY REGISTRATION is available online at: www.safcoproducts.com

• L'INSCRIPTION POUR LA GARANTIE DU PRODUIT est disponible sur l'Internet : www.safcoproducts.com

• EI REGISTRO PARA LA GARANTÍA DEL PRODUCTO está disponible en la Internet: www.safcoproducts.com

For questions or concerns, please call **1-800-664-0042**
available Monday-Friday 7:00 AM to 6:00 PM (Central Time) (English-speaking operators)

Si vous avez des questions pour poser ou les préoccupations pour exprimer, connecter **au 1-800-664-0042** de 7H00 à 18H00 (Heure centrale) (Opérateurs de langue anglaise)



Si usted tiene preguntas o preocupaciones, por favor llame **1-800-664-0042** de 7:00 AM a 6:00 PM (Hora Central) (Operadores que hablan inglés)

Two People Recommended.

On recommande que l'assemblage soit effectué par deux personnes.

Se recomienda dos personas para el ensamblaje.

Parts List / Liste des Pièces / Lista de Piezas			
Code/ Código	DESCRIPTION / DESCRIPTION / DESCRIPCIÓN	Qty./ Qté/ Cant.	Part No./ N° de Pièce / No. de Pieza
(A)	Back Panel / Panneau arrière / Tablero trasero	1	7751-01\$
(B)	Top Panel / Panneau Supérieur/ Panel Superior	1	7751-05\$
(C)	Bottom Panel / Panneau Inférieur / Panel Inferior	1	7751-02\$
(D)	Side Panel, Left / Panneau latéral, gauche / Panel lateral, izquierda	1	7751-03\$
(E)	Side Panel, Right / Panneau latéral, droit / Panel lateral, derecha	1	7751-04\$
(F)	Divider / Séparateur / Separado	6	7751-06\$
(G)	Mail Tray / Bac à Courrier / Correo Bandeja	20	7751-07\$
(H)	Label Sheet(Not Shown) / Feuille d'étiquettes (Non Représenté)/ Hoja de Etiquetas (No Representados)	1	7751-35

Hardware Pack / Paquet Matériel / Paquete Material:		
7751-19\$		7757-19 1478-19
 <p>I Label Holder <i>Porte-étiquette</i> Portaetiquetas Qty. / Qté. / Cant. 25 7751-08\$</p>	 <p>J Plastic connector <i>Connecteur en Plastique</i> Conector de Plástico Qty. / Qté. / Cant. 2 7757-16</p>	 <p>K Push Pin <i>Pousser la Broche</i> Clavija Empuje Qty. / Qté. / Cant. 4 7757-17</p>

§ Note: When corresponding about parts, be sure to state color: Black (BL), or Gray (GR) .

§ Noter: Quand correspondre au sujet de parties, soyez sûr d'affirmer la couleur: Noir (BL) ou Gris (GR) .

§ Note: Al corresponder sobre las piezas, esté seguro declarar el color: Negro(BL)o Gris (GR).

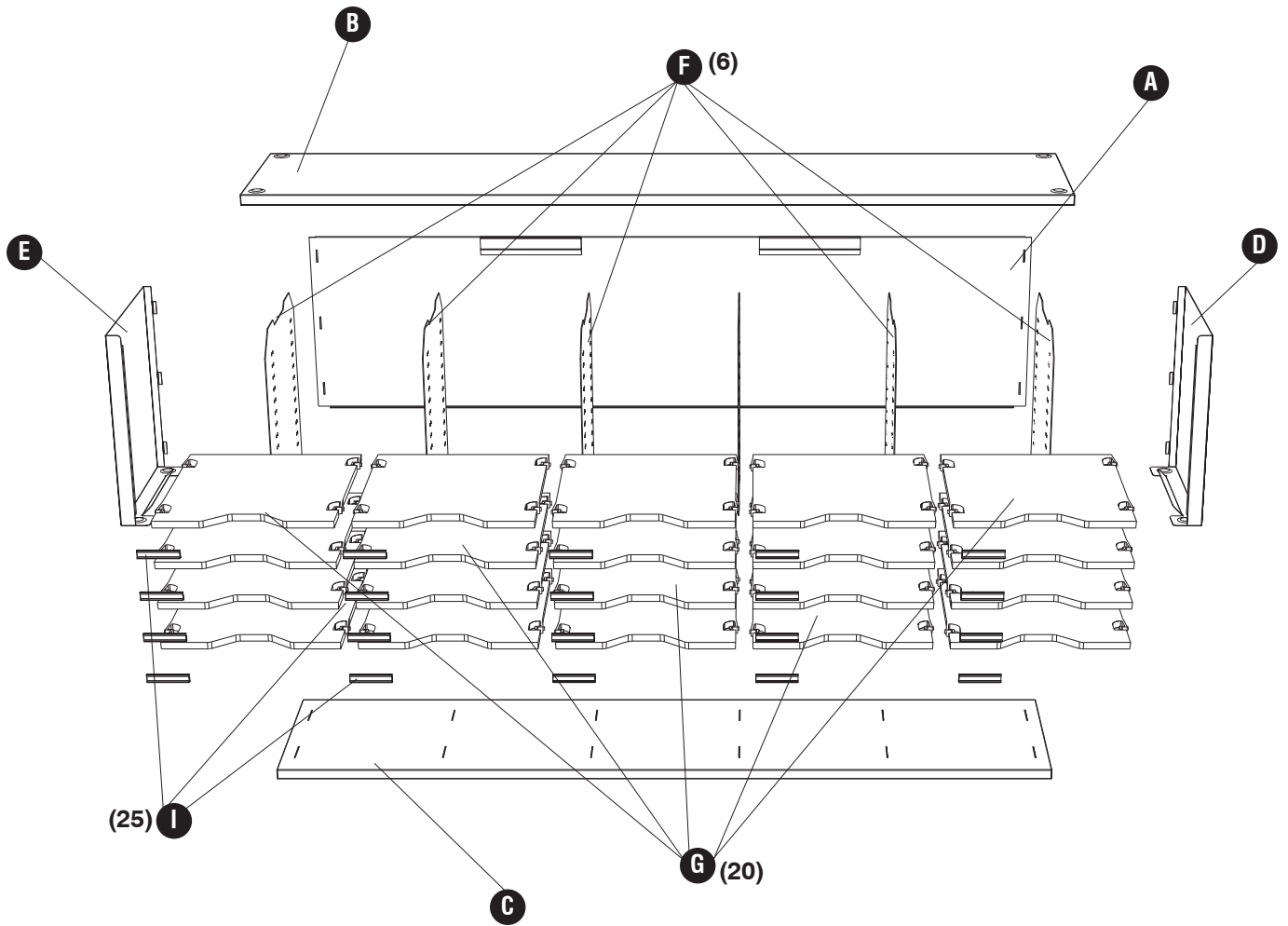

1

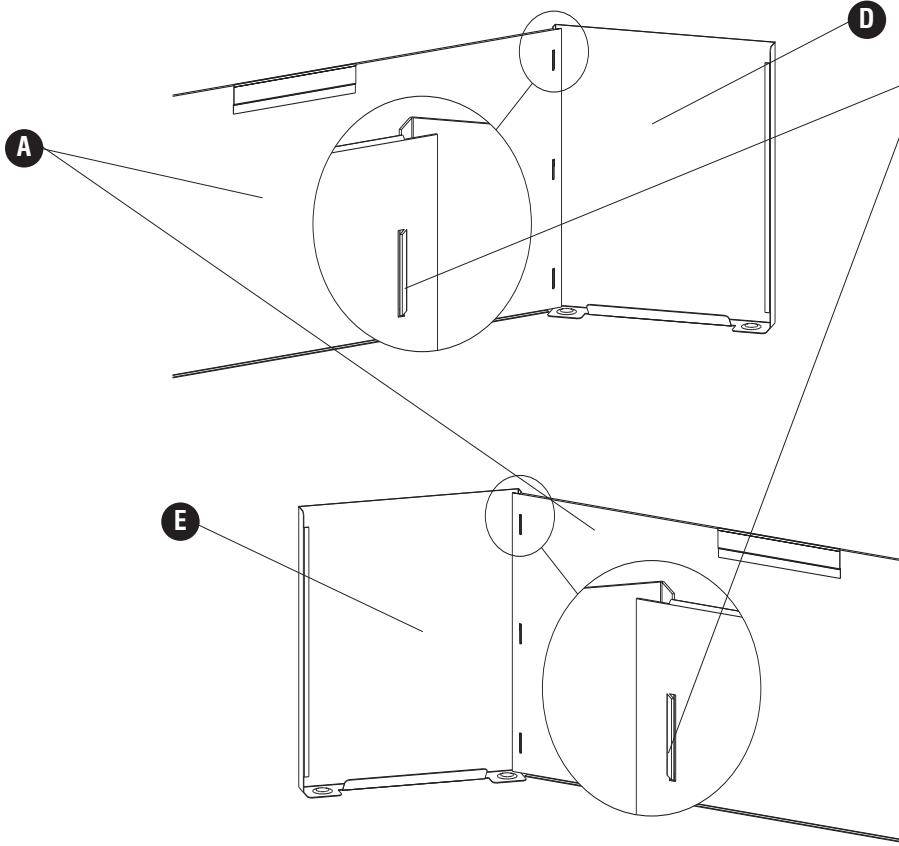

Insert tabs into slots
Insérez les languettes dans les fentes
Inserte las lengüetas en las ranuras

2

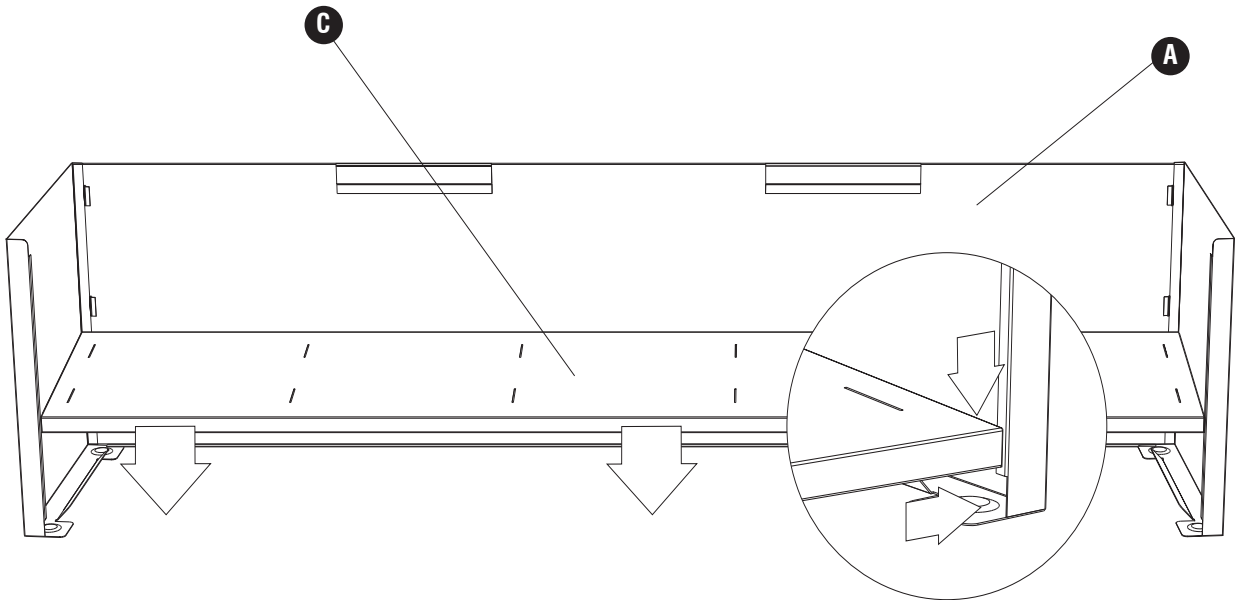

3

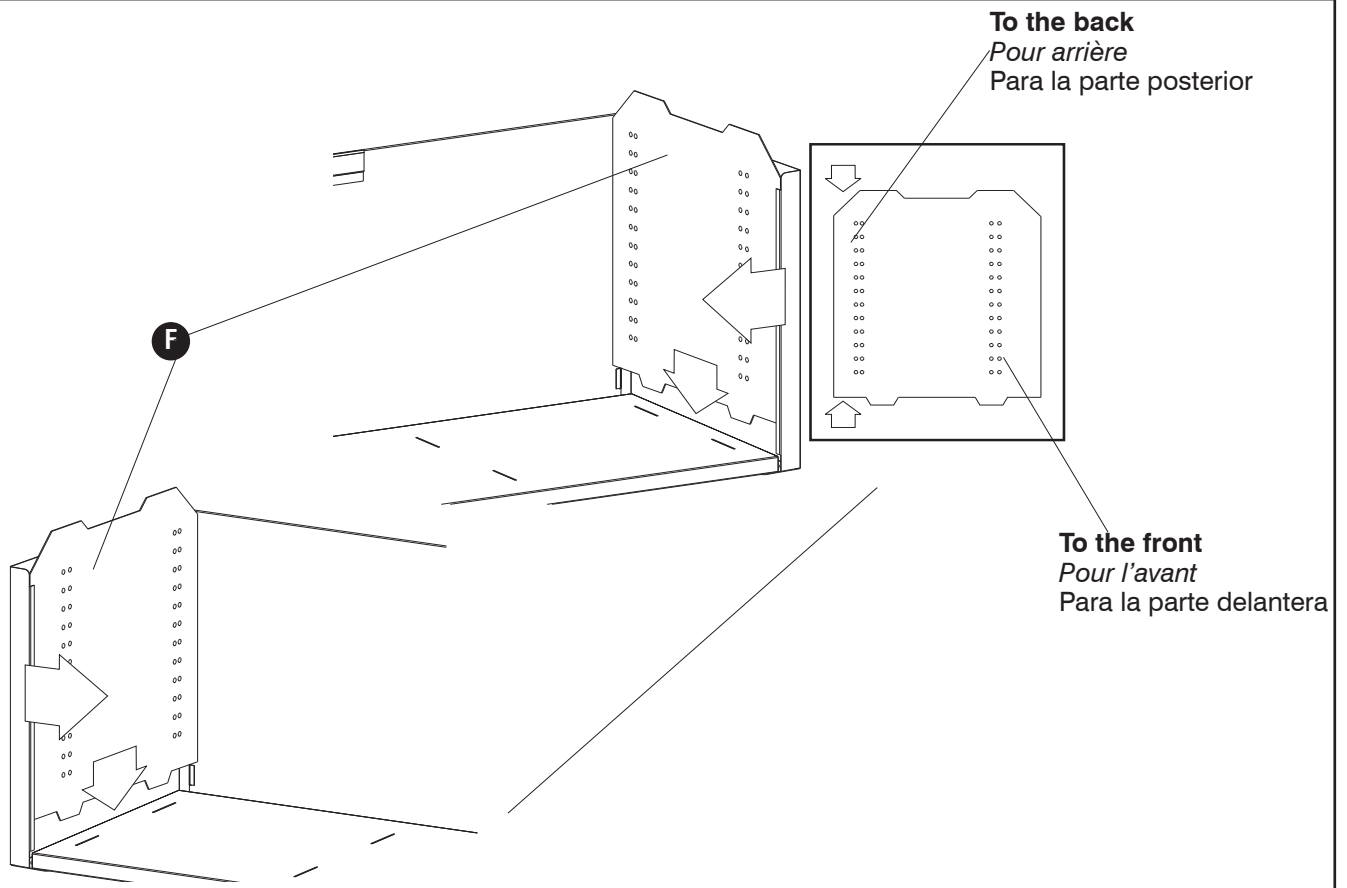

4

Two People Recommended.
On recommande que l'assemblage soit effectué par deux personnes.
Se recomienda dos personas para el ensamblaje.

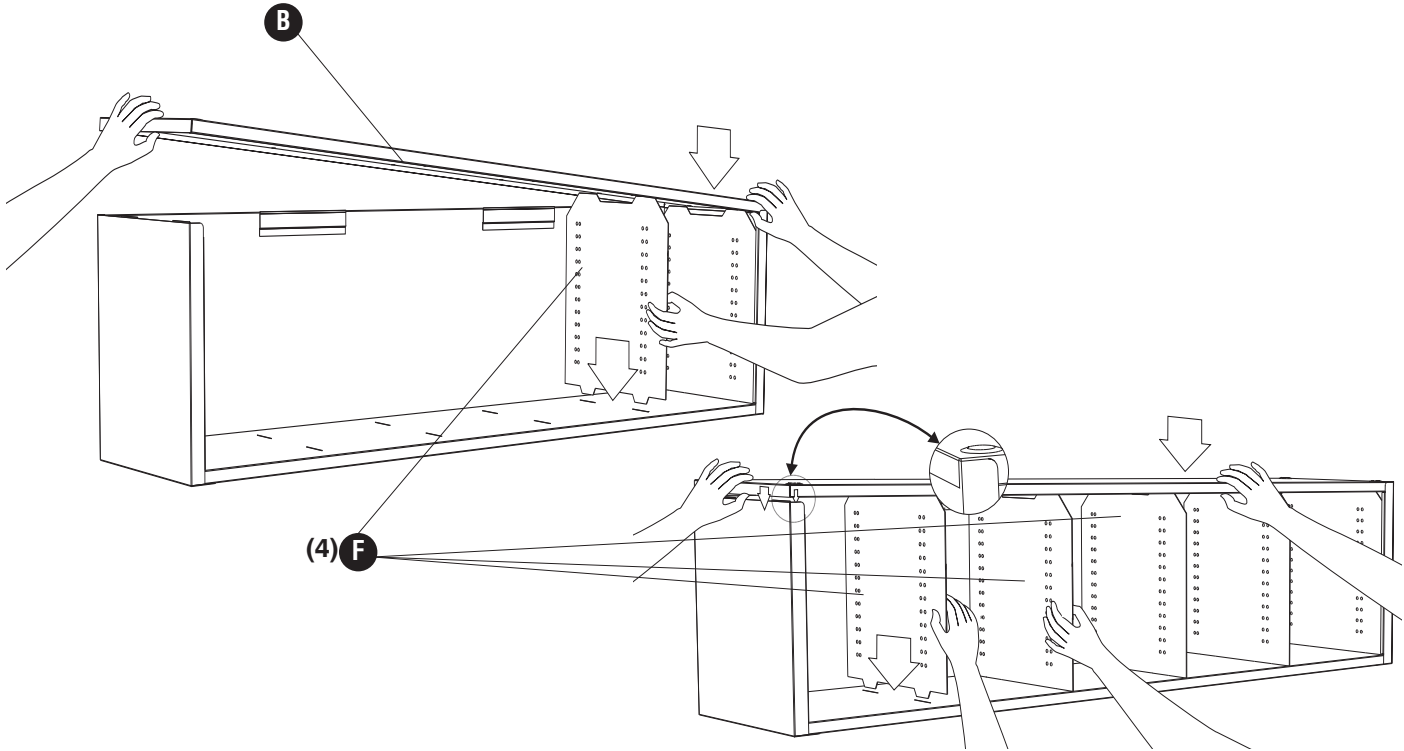

5

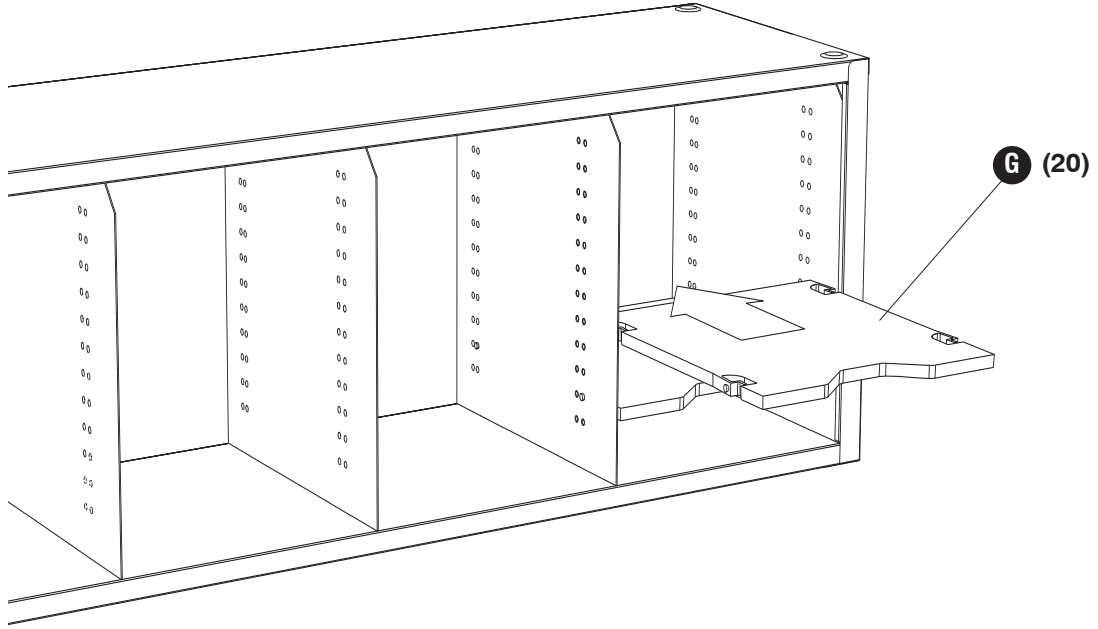

6 **I** (25)

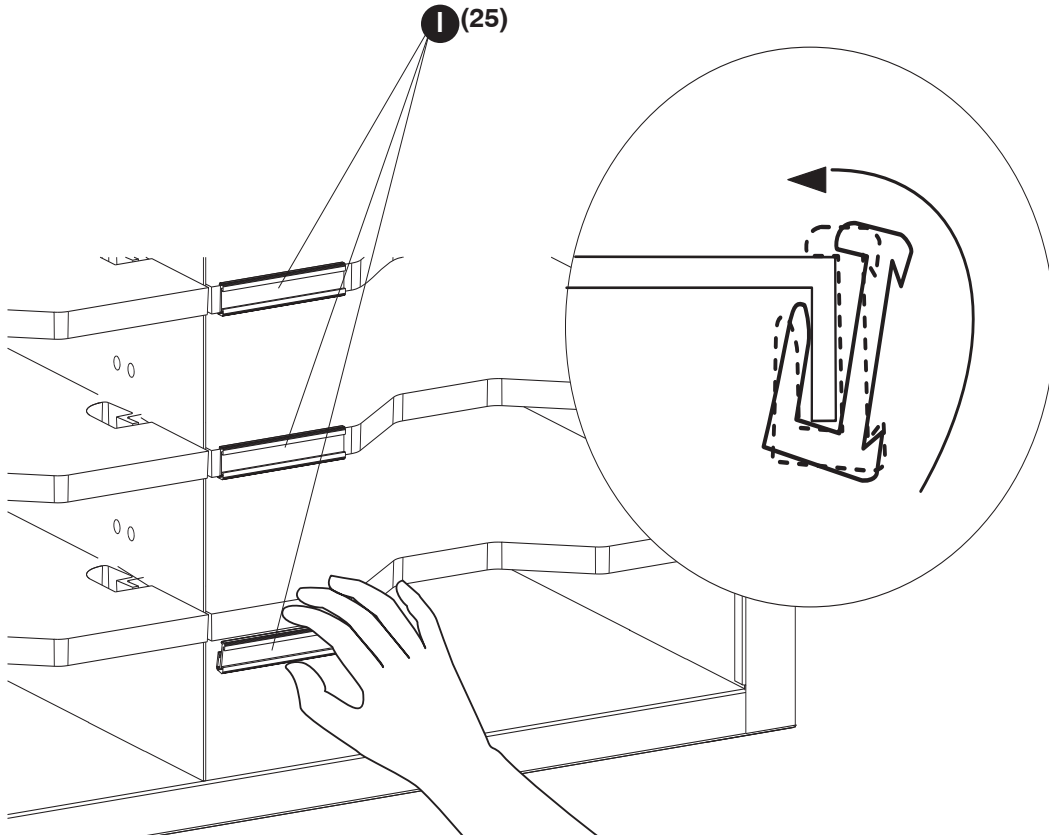

7

J

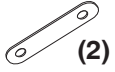

(2)

K



(4)

Follow this step only if stacking 2 units together.

Suivez cette étape uniquement si empilage de 2 unités ensemble.

Siga este paso sólo si apilar 2 unidades juntas.

