

Sort and count your parts!

PARTS LIST			
LETTER CODE	DESCRIPTION	QTY.	PART NO.
A	Top Panel	1	1953-01
B	Screw Post	8	HFFMFB
C	Back Panel	1	1953-04
D	Locking Cam	8	HFFMFC
E	Keyboard Shelf	1	1953-07
F	Left Shelf Rail	1	1970-17
G	Right Shelf Rail	1	1970-18
H	Small Flat Head Screw	12	1902-23
I	Left Side Panel	1	1953-02
J	Right Side Panel	1	1953-03
K	Left Cabinet Rail	1	1970-15
L	Right Cabinet Rail	1	1970-16
M	Large Screw	4	8917-27
N	Caster Bracket	4	8917-10
O	Caster without Brake	2	8917-25
P	Caster with Brake	2	8917-24
Q	Small Pan Head Screw	2	1951-23
R	Bumper	2	1951-28
S	Mouse Tray	1	1951-08
T	Clevis Pin	1	1951-26
U	Plastic Washer	4	1951-31
V	Hairpin Cotter	1	1951-27
W	Mouse Pad	1	1951-11
X	Wrist Rest	1	1972-10

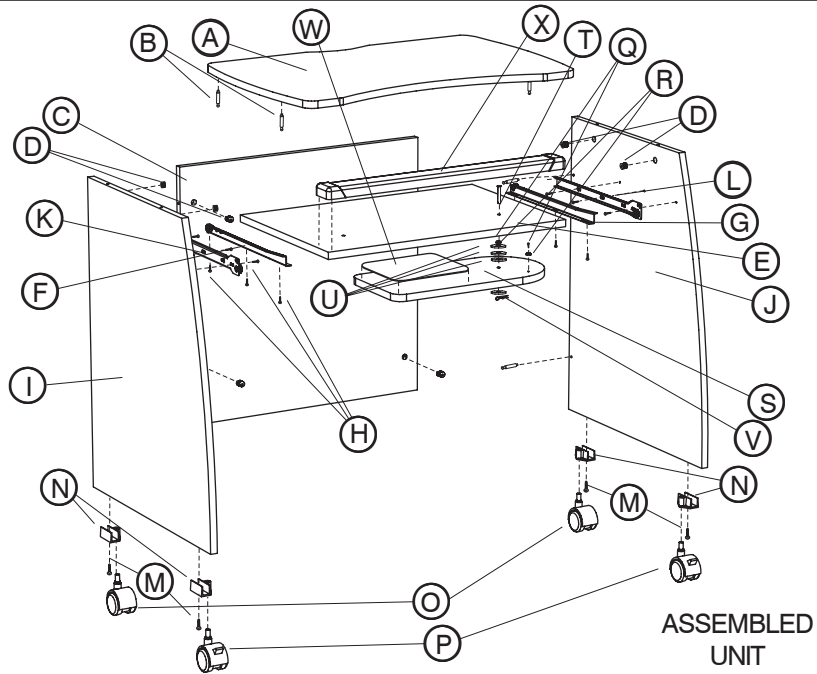

ASSEMBLED UNIT
MODEL 1953

TOOLS REQUIRED: Phillips Screwdriver
(Two People Recommended)

For questions or concerns, please call
Safco Consumer Hot Line 1-800-664-0042
available Monday-Friday 8:00 AM to 4:30 PM (Central Time)
(English-speaking operators)



Properly identify the four types of rails used!

The Cabinet Rails (K, L) have C-shaped cross sections; rollers are at the FRONT, and the Left Cabinet Rail is stamped "CL" near the roller, while the Right Cabinet Rail is stamped "CR".

The Shelf Rails (F, G) have Z-shaped sections; rollers are at the BACK, and they are stamped "DR" for Right and "DL" for Left.

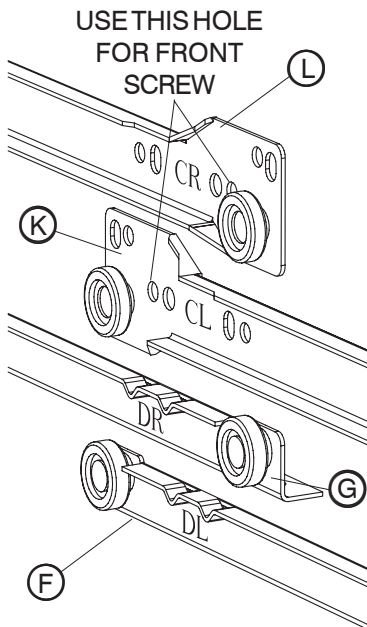

1 Work on a smooth, clean surface.
Locate the (A) Top Panel and position it with the holes up. Insert four (B) Screw Posts into the holes, and tighten with a screwdriver (do not overtighten!)

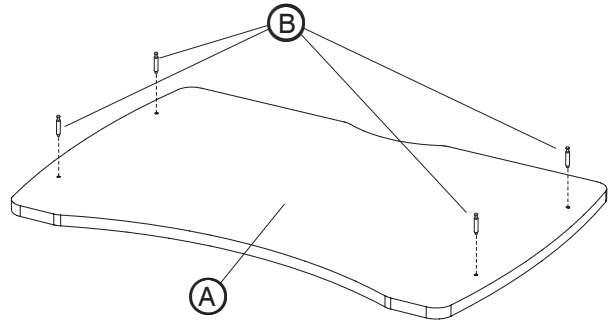

2 Lay the (C) Back Panel down with the large holes facing up. Insert four (D) Locking Cams, with the arrows pointing toward the nearest SIDE edge.

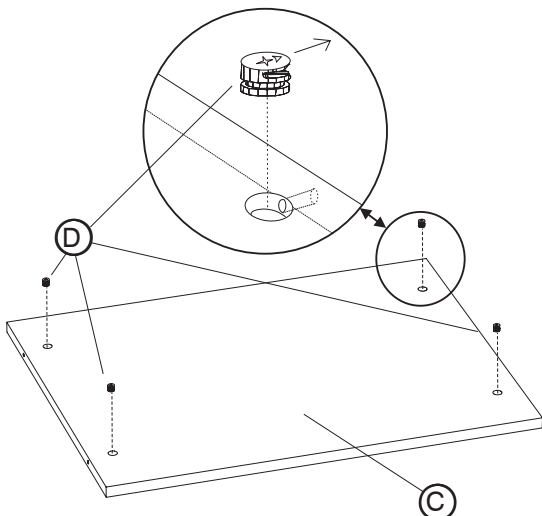

3 Locate the (E) Keyboard Shelf and position it with the holes along the edges facing up. Fasten a (F) Left Shelf Rail and a (G) Right Shelf Rail (Z-shaped ends) at the sides of the Shelf, with the rollers toward the BACK of the shelf. Use three (H) Small Flat Head Screws per Rail.

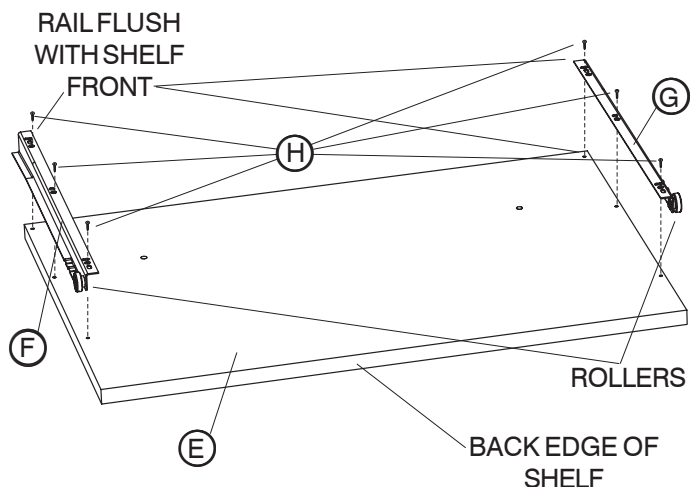

- 4** Lay out the (I) Left Side Panel and the (J) Right Side Panel with the holes facing up.

Insert two (D) Locking Cams into the large holes at the top of each Side Panel with the arrows pointing toward the TOP edge.

On the Left Side Panel, install the (K) Left Cabinet Rail (C-shaped ends), using three Small Flat Head Screws, into the small set of holes in the Side Panel, making sure that the rollers are facing the FRONT (curved edge) of the Panel and using the hole CLOSEST to the roller.

Do the same with the Right Side Panel, using the (L) Right Cabinet Rail.

Screw two (B) Screw Posts into the holes along the back edge of each Panel.

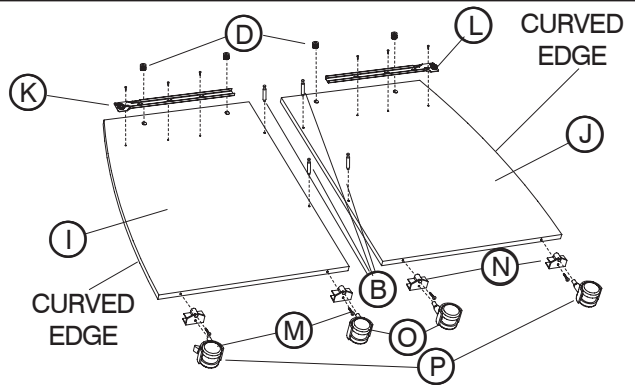

Using one (M) Large Screw each, attach the (N) Caster Brackets to the bottom edges of the Side Panels (caster sockets should be on the same side as the Panel holes.)

Push the two (O) Casters without Brakes into the back Caster Brackets. Push the (P) Casters with Brakes into the front Brackets.

- 5** Lift the (C) Back Panel over the (I) Left Side Panel, aligning the (B) Screw Posts on the back edge of the Left Side Panel with the holes in the end of the Back Panel. Slide the Back Panel down onto the Screw Posts, and secure by turning each of the two (D) engaged cams clockwise until they stop.

IMPORTANT: to prevent possible damage during assembly, a second person should support the Back Panel in its upright position.

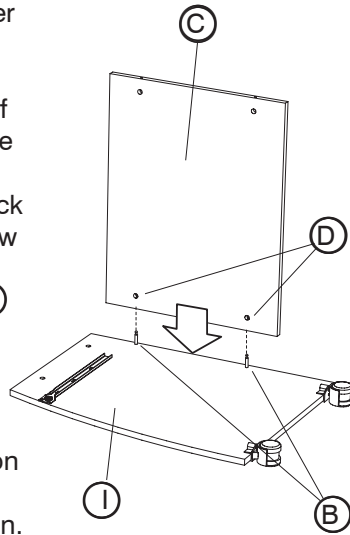

- 6** Carefully lift the assembly upright. While one person holds it in position, slide the Screw Posts on the (J) Right Side Panel into the holes in the edge of the Back Panel. Tighten both Cams as before.

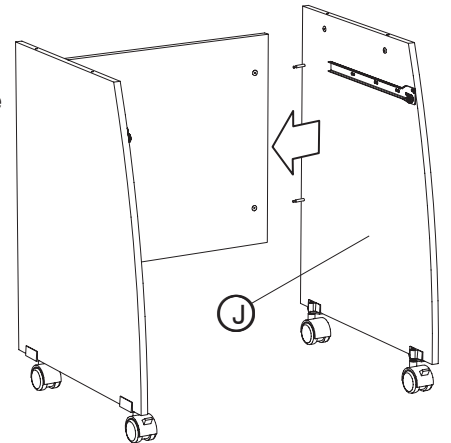

- 7** Slide the (A) Top Panel into position, and lock the remaining Cams on the Side Panels.

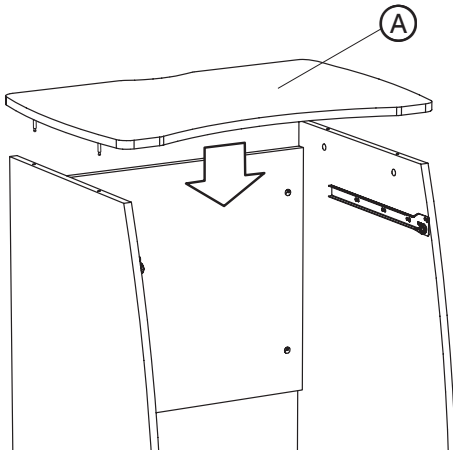

- 8** Install the (E) Keyboard Shelf onto the set of Cabinet Rails: lift the back rollers on the Shelf Rails over the front rollers on the Cabinet Rails, tilt the Shelf enough to start the Shelf moving, and lower the shelf to push it all the way into place.

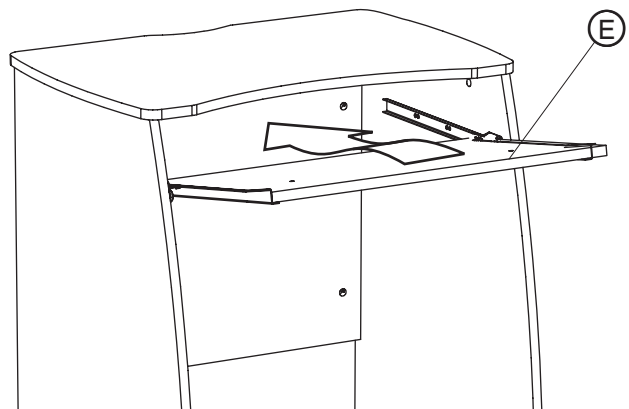

- 9** Using (Q) Small Pan Head Screws, screw the two (R) Bumpers into the off-center holes on the (S) Mouse Tray. From the top side of the (E) Keyboard Tray, insert the (T) Clevis Pin through the appropriate hole (the left center hole if the Mouse Tray is to swing to the left, otherwise the right hole). Place three (U) Plastic Washers onto the shaft of the Clevis Pin, then the Mouse Tray (bumper side against the Keyboard Shelf), one more Plastic Washer, and secure with the (V) Hairpin Cotter through the bottom hole in the Clevis Pin. Place the (W) Mouse Pad on the Mouse Tray.

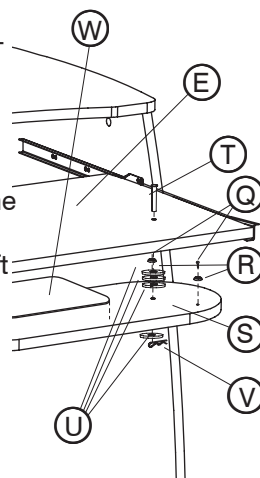

- 10** Remove the protective paper strip from the bottom of the (X) Wrist Rest, and place the Wrist Rest onto the Keyboard Shelf; the Wrist Rest should be flush with the front edge of the Shelf. Press down firmly to affix the Wrist Rest.

