

30" Square-Edge Bookcase

1501

Bibliothèque à rebords carré (76cm) • Estantería para libros con esquina en ángulo recto (30 pulg.)

ASSEMBLY INSTRUCTIONS

Two People Recommended

INSTRUCTIONS DE MONTAGE • INSTRUCCIONES DE ENSAMBLAJE
Deux Personnes ont Recommandé • Dos Personas Recomendaron

TOOLS REQUIRED: Phillips Screwdriver, Rubber Mallet

PRODUCT WARRANTY REGISTRATION is available online at: www.safcoproducts.com

• **Outils Requis :**

Tournevis à pointe cruciforme, Maillet en caoutchouc
• L'INSCRIPTION POUR LA GARANTIE DU PRODUIT est disponible sur l'Internet : www.safcoproducts.com







• **HERRAMIENTAS REQUERIDAS:**

Destornillador Phillips®, Mazo de goma
• EI REGISTRO PARA LA GARANTÍA DEL PRODUCTO está disponible en la Internet: www.safcoproducts.com

PARTS LIST / LISTE DES PIÈCES / LISTA DE PIEZAS

CODE / CODIGO	DESCRIPTION / DESCRIPTION / DESCRIPCIÓN	QTY. / QUANTITÉ / CANTIDAD	PART NO. / N° DE PIECE / NO. DE PIEZA
(A)	Left Side Panel / Panneau latéral gauche / Tablero lateral izquierdo	1	1501-54\$
(B)	Right Side Panel / Panneau latéral droit / Tablero lateral derecho	1	1501-53\$
(C)	Bottom Panel / Panneau inférieur / Tablero del fondo	1	1501-52\$
(D)	Baseboard / Plinthe / Rodapié	1	1501-57\$
(E)	Top Panel / Panneau supérieur / Tablero superior	1	1501-55\$
(F)	Top Rail / Tableau supérieur / Tablón superior	1	1501-56\$
(G)	Back Panel / Panneau arrière / Tablero trasero	1	1501-51\$
(H)	Adjustable Shelf / Étagère ajustable / Estante ajustable	1	1501-58\$
(I)	Hardware Pack / Paquet matériel / Paquete material	1	1501-69\$

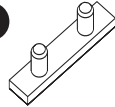
HARDWARE PACK / PAQUET MATÉRIEL / PAQUETE MATERIAL 1501-69\$

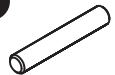
 <p>J Screw Post Tige-vis Poste roscado Qty. / Qte. / Cant.: 8 #1501-70NC</p>	 <p>K Locking Cam Came Leva de enganche Qty. / Qte. / Cant.: 8 #1501-73NC</p>	 <p>L Wood Dowel Cheville en bois Espiga de madera Qty. / Qte. / Cant.: 18 #1501-80NC</p>
 <p>M Small Screw Petit Vis Tornillo pequeño Qty. / Qte. / Cant.: 16 #1501-74NC</p>	 <p>N Foot Pied Pata Qty. / Qte. / Cant.: 4 #1501-59NC</p>	 <p>O Cam Cap Couvercle pour la Came Cubierta para la leva Qty. / Qte. / Cant.: 4 #1501-75\$</p>
<p>Note: When corresponding about parts, be sure to state color: Mahogany (MH), Walnut (WL), Medium Oak (MO), Light Oak (LO) or Cherry (CY). §Note: Quand correspondre au sujet de parties, soyez sûr d'affirmer la couleur: Acajou (MH), Noyer (WL), Chêne Moyen (MO), Chêne Clair (LO) ou Cerise (CY). §Note: Al corresponder sobre las piezas, esté seguro declarar el color: Caoba (MH), Nogal (WL), Roble Pálido (MO), Roble Claro (LO) o Cereza (CY).</p>		
 <p>P Shelf Peg Cheville de tablette Espiga de la repisa Qty. / Qte. / Cant.: 4 #1501-76NC</p>		

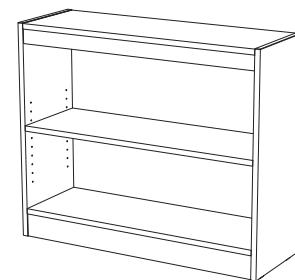
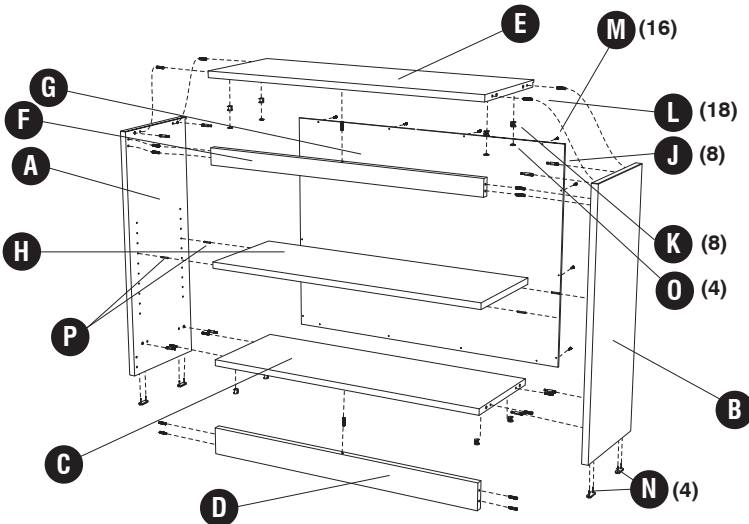

Si vous avez des questions pour poser ou les préoccupations pour exprimer, connecter au **1-800-664-0042** de 8H00 à 16H30 (Heure centrale) (Opérateurs de langue anglaise)

Si usted tiene preguntas o preocupaciones, por favor llame **1-800-664-0042** de 8:00 AM a 4:30 PM (Hora Central) (Operadores que hablan inglés)

1 **J** (8)

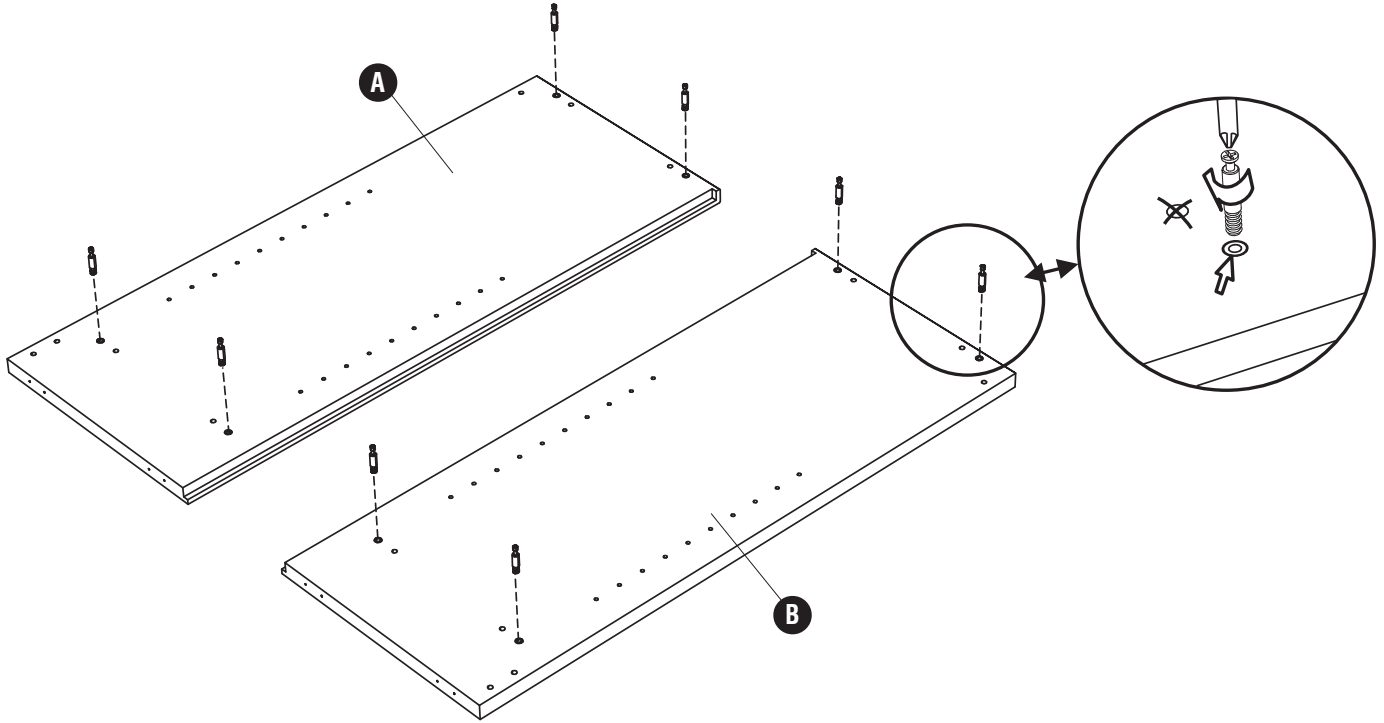

2 **L** (18)

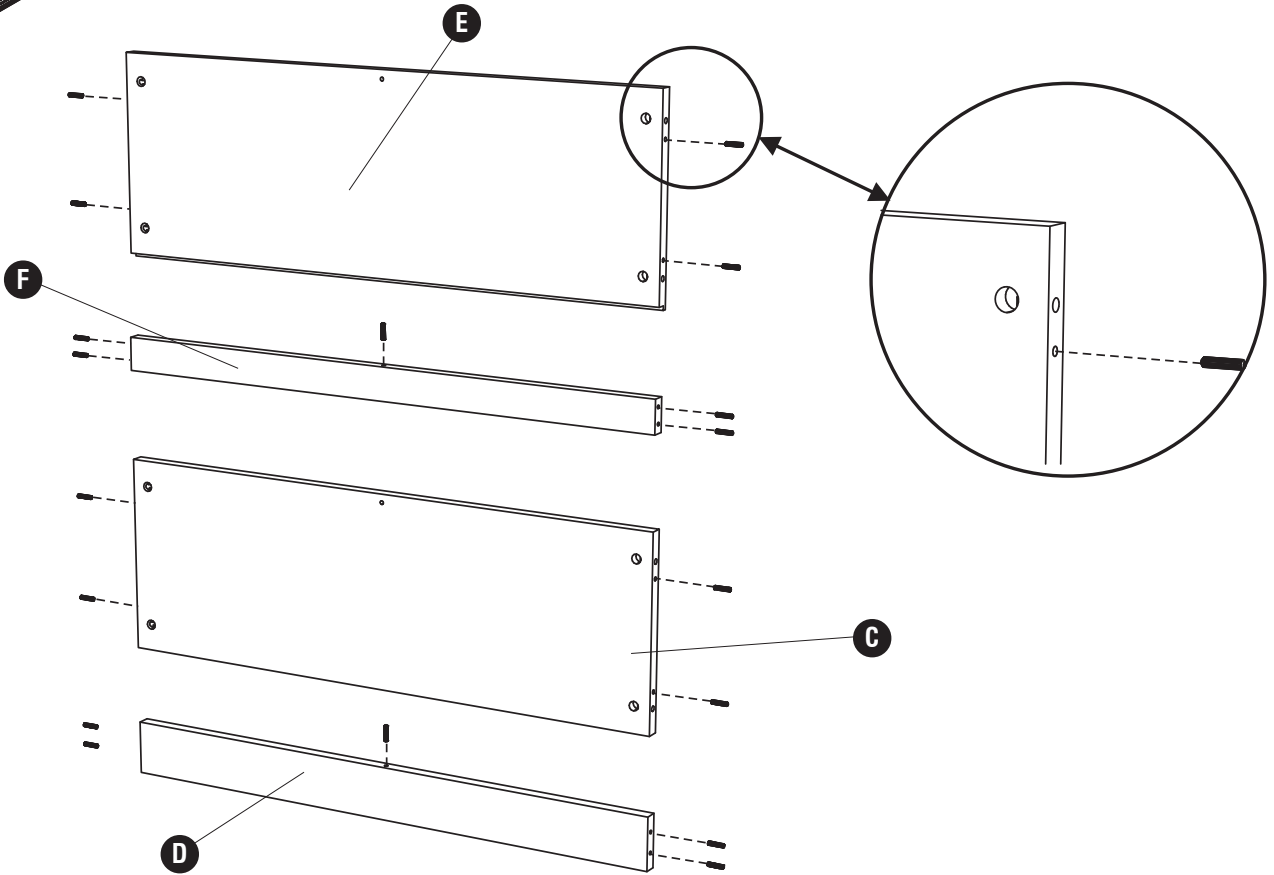

3

K



(8)

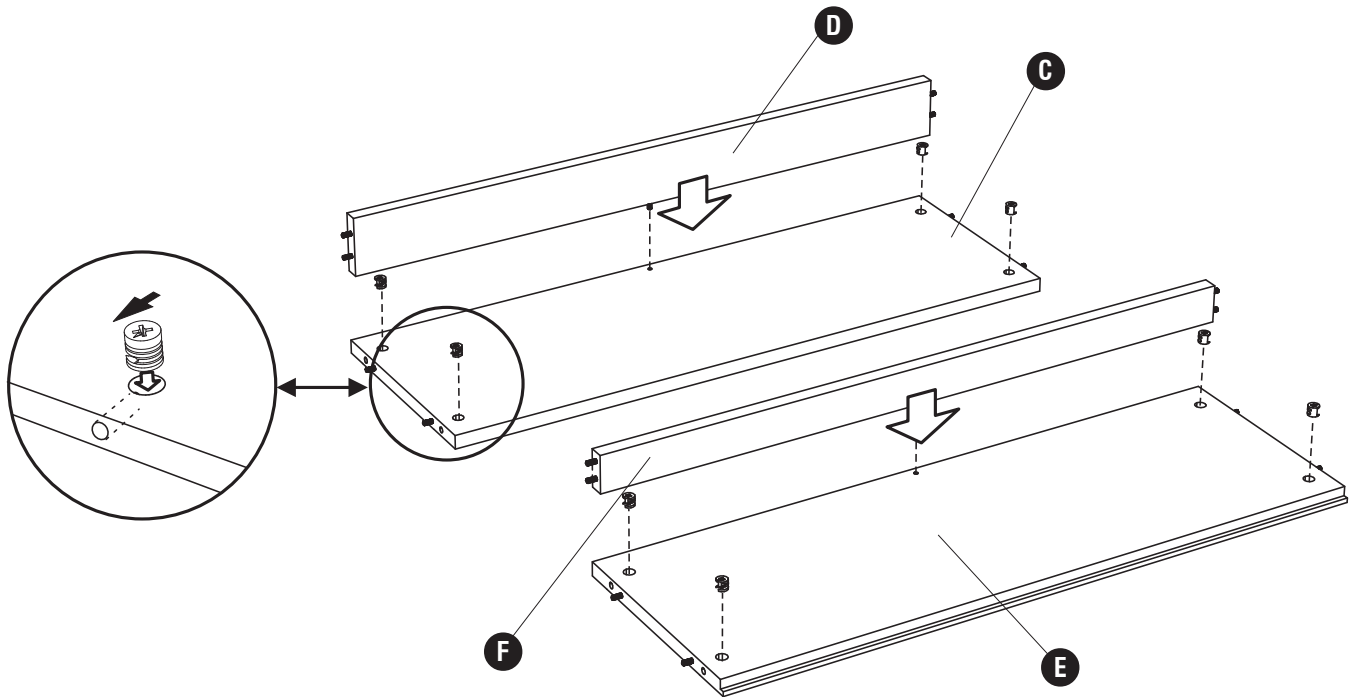

4

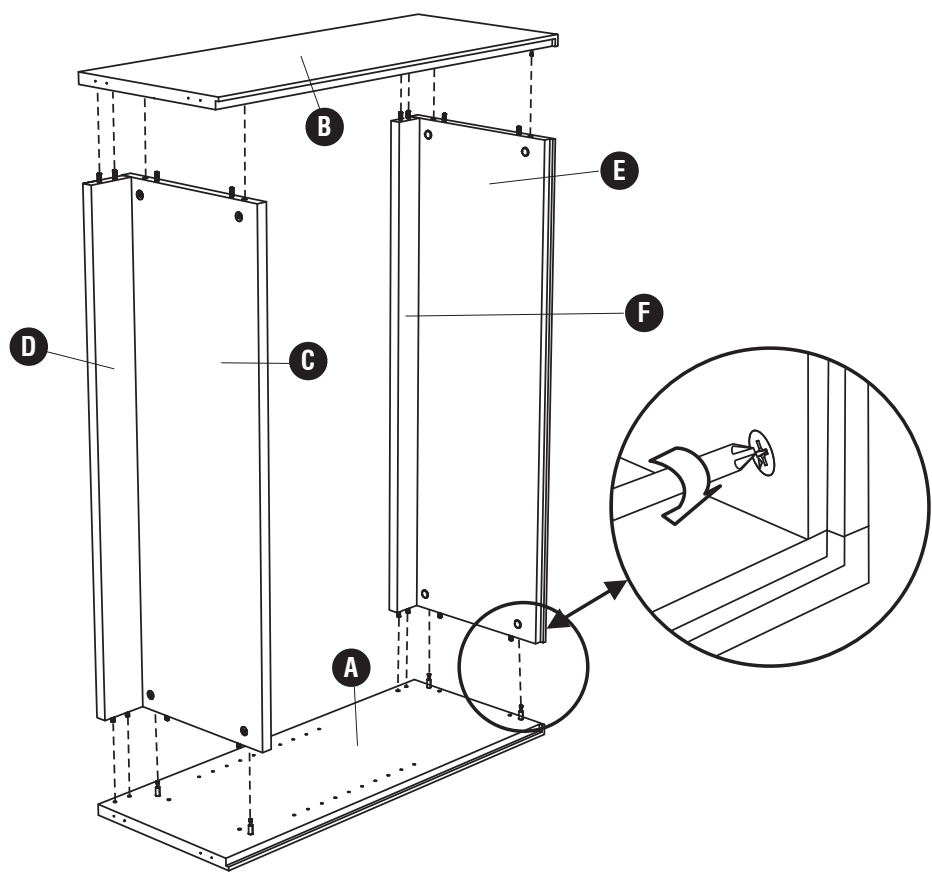

5

M (16)

N (4)

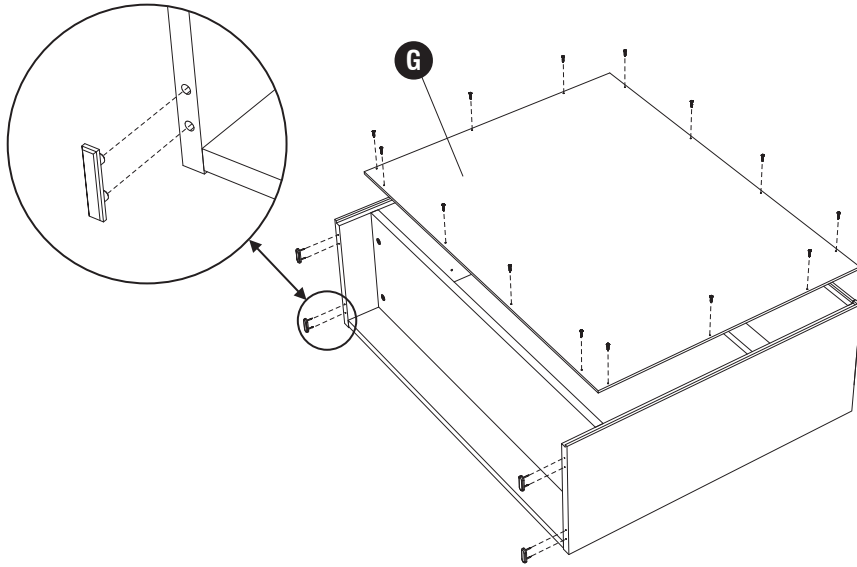

6

P (4 per shelf)
(4 par étagère)
(4 por estante)

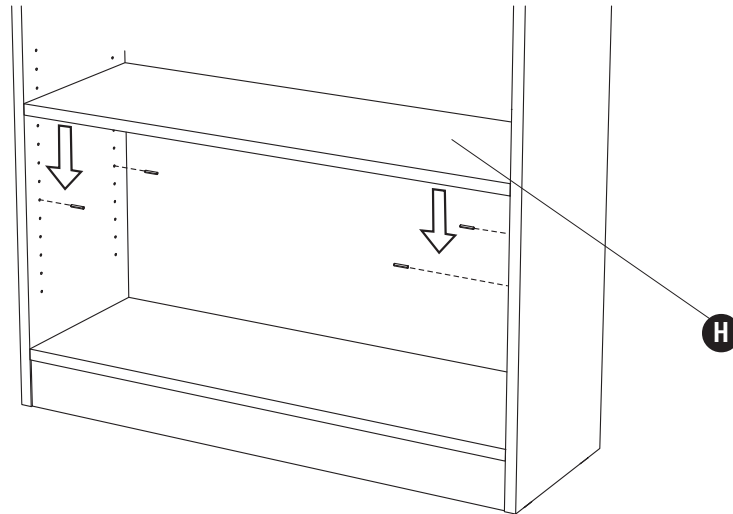

7

O (4)

