

KELVIN LED CLAMP

| | |
|-----------------------|---|
| Mounting | : Clamp |
| Lamps description | : 30 TOP LED 1700k 275 lm total - cri 95 - 8w |
| Environment | : Indoor |
| Finish | : Anthracite, Shiny black, Shiny white |
| Technical description | : Adjustable table lamp providing direct lighting, with pantograph arm and adjustable head. Fused aluminum alloy body. Die-cast aluminum outer head, with injection-molded methacrylate diffuser. Painted CNC machined extruded aluminum CLAMP. Extruded aluminum alloy square tube (0.5 x 0.5 inch) structure, machined mechanically, so that it houses a stainless steel load-compensation spring and injection-molded acetal resin sliding blocks. 0.11 inch diameter wire outer tie rods. The ON/OFF switch is electronic with optical mechanism located in the head. |

ELECTRICAL

| | |
|-------------|-----------|
| Emergency | : Without |
| Voltage (V) | : 120 |

PHYSICAL

| | |
|-----------------------|--------------|
| Supply | : Power cord |
| Cord length(inch) | : 59 |
| Construction material | : Aluminum |
| Weight (lbs) | : 3,6 |

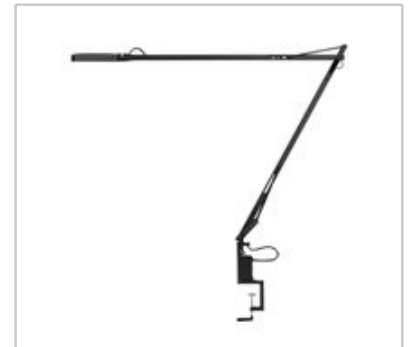

Kelvin LED Clamp
design by Antonio Citterio with Toan Nguyen

Adjustable table lamp providing direct lighting

Reference Code

- F3324030A Shiny black
- F3324009A Shiny white
- F3324033A Anthracite

Certifications

