

SERVICE MANUAL

Models

RGD3300H

RGD5000H

GENERATORS

PUB-GS2380

Rev. 06/08



SUBARU

Robin Power Products

CONTENTS

<i>Section</i>	<i>Title</i>	<i>Page</i>
1.	SPECIFICATIONS	1
2.	PERFORMANCE CURVES	2
3.	GENERAL DESCRIPTION	
3-1	External View	3
3-2	Control Panel	4
3-3	Serial Number and Specification Number	4
4.	CONSTRUCTION AND FUNCTION	
4-1	Construction	5
4-2	Function	5
4-3	Generator Operation	9
5.	SAFETY PRECAUTIONS	12
6.	RANGE OF APPLICATIONS	13
7.	MEASURING PROCEDURES	
7-1	Measuring Instruments	16
7-2	AC Output Measuring	17
7-3	Measuring Insulation Resistance	18
8.	CHECKING FUNCTIONAL MEMBERS	
8-1	AC Receptacles	19
8-2	Circuit Breaker	19
8-3	Stator	20
8-4	Rotor Assembly	20
8-5	Condenser	21
8-6	Diode Rectifier	22
9.	DISASSEMBLY AND ASSEMBLY	
9-1	Preparation and Precautions	23
9-2	Special Tools for Disassembly and Assembly	23
9-3	Disassembly Procedures	24
9-4	Assembly Procedures	33
9-5	Control Box	42
10.	TROUBLE SHOOTING	
10-1	No AC Output	43
10-2	AC Voltage is Too High or Too Low	45
10-3	AC Voltage is Normal at No-load, but the Load Cannot be Applied.	46
10-4	No DC Output	47
11.	WIRING DIAGRAM	48

1. SPECIFICATIONS

Model		RGD3300H	RGD5000H	
GENERATOR	Type	Brushless, self-exciting, 2-poles, single phase		
	Voltage regulator	Condenser type		
	AC output	Frequency (Hz)	60	
		Rated voltage (V)	120, 120/240	
		Rated output (VA)	3000	4500
		Maximum output (VA)	3300	5000
	DC output (V-A)	12-8.3		
	Power factor	1.0		
	Over current protector	No-fuse Breaker		
	Noise level at rated output (dB-7 m)	77.5	79.7	
ENGINE	Model	1B30	1B40	
	Type	Air-cooled, 4-cycle, single cylinder diesel engine		
	Displacement (ml) [cu. in.]	347 [21.17]	462 [28.19]	
	Fuel	Automobile diesel light oil		
	Fuel tank capacity (L) [US gal.]	12.0 [3.17]		
	Continuous operating hours at rated output (h)	8.5	5.9	
	Starting system	Electric and Recoil starter		
Dimensions L × W × H (mm) [in.]	790 × 515 × 576 [31.10 × 20.28 × 22.68]			
Dry Weight (kg) [lb]	87 [191.8]	104 [229.3]		

Specifications are subject to change without notice.

2. PERFORMANCE CURVES

2-1 MODEL RGD3300H

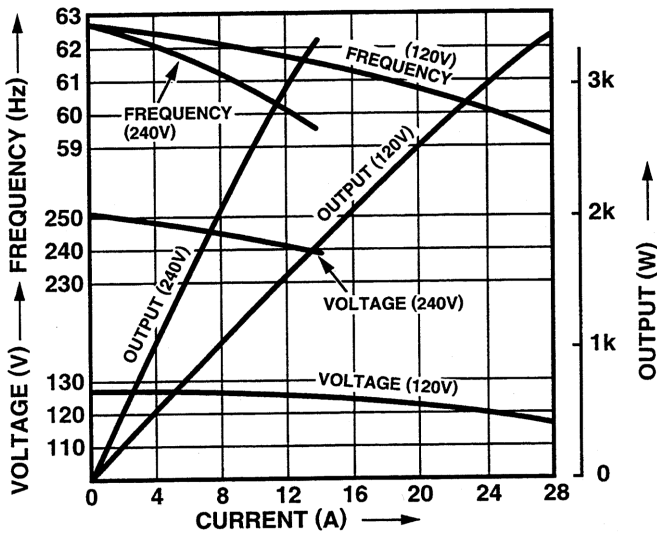

RGD3300H

Output Max.....3300 W
 Rated3000 W
 Frequency60 Hz
 Voltage110 V

2-2 MODEL RGD5000H

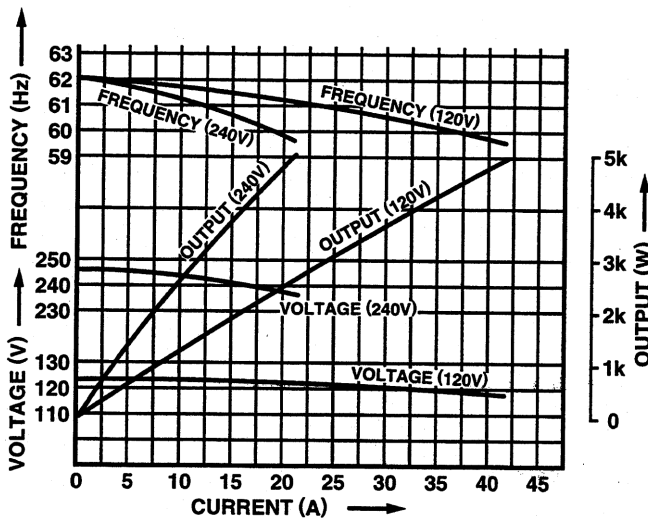

RGD5000H

Output Max.....5000 W
 Rated4500 W
 Frequency60 Hz
 Voltage110 V

2-3 DC OUTPUT (RGD3300H, RGD5000H)

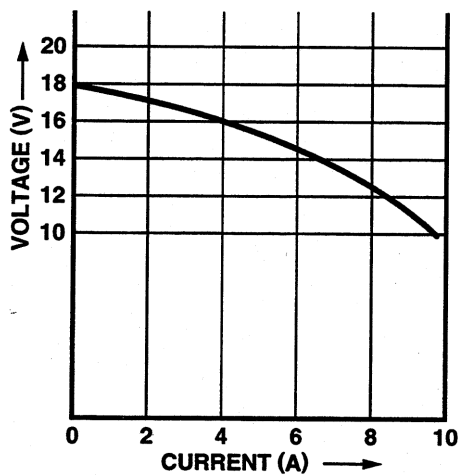

DC Voltage12 V
 DC Ampere8.3 A
 DC Output100 W

The voltage curve shown in the left indicates the characteristic of DC output when charging a battery.

The voltage may be decreased by 20% when the resistance load is applied.

NOTE: It is possible to use both DC and AC outputs simultaneously up to the rated output in total.

3. GENERAL DESCRIPTION

3-1 EXTERNAL VIEW

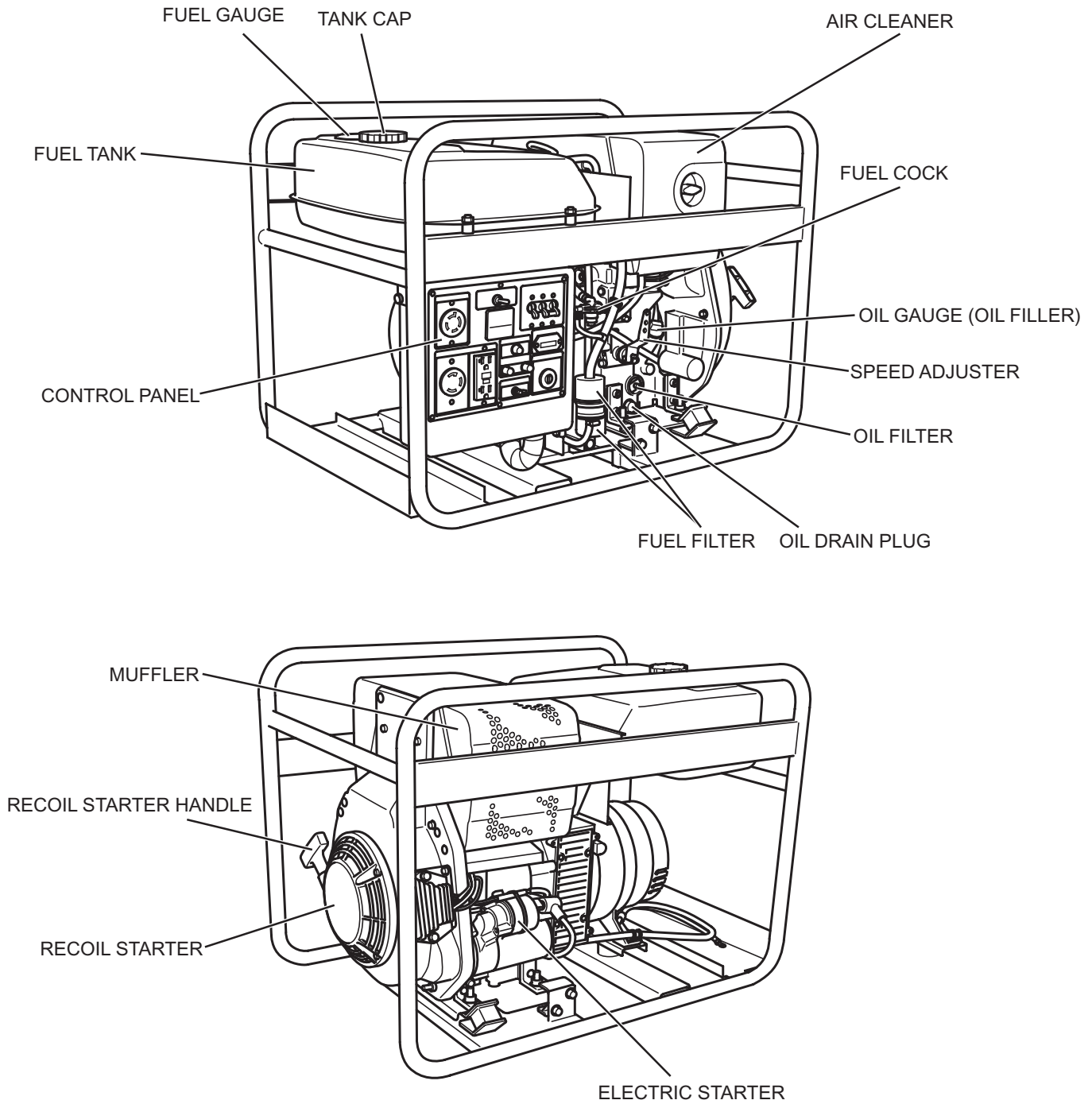

3-2 CONTROL PANEL

- RGD3300H/5000H: 60 Hz-120 V, 240 V TYPE

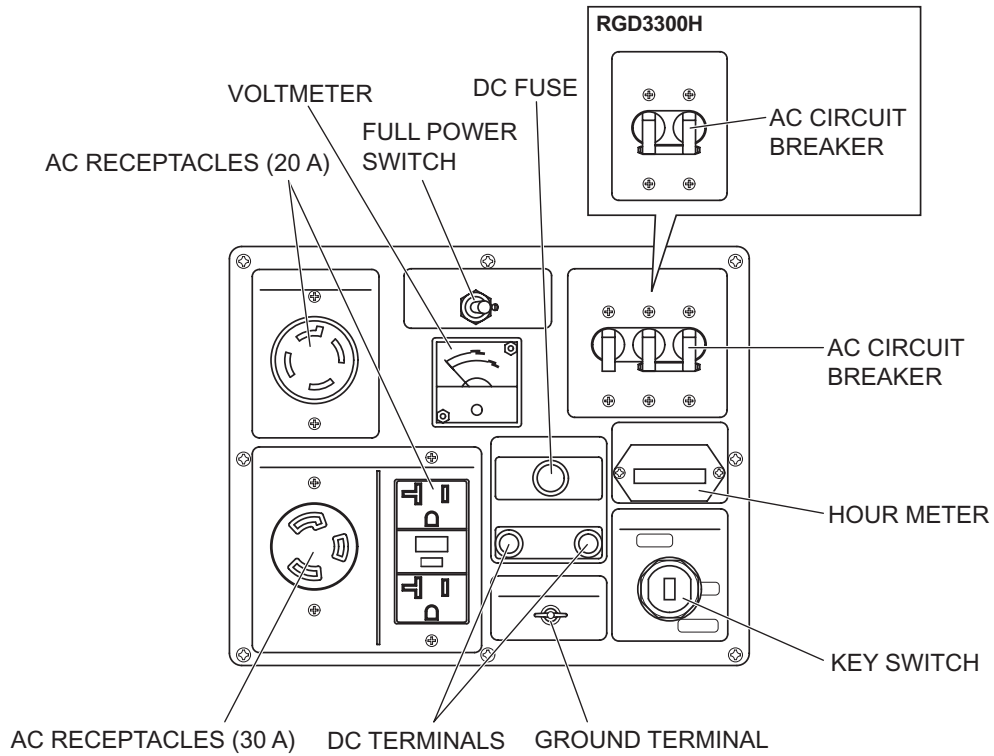

3-3 SERIAL NUMBER AND SPECIFICATION NUMBER

Serial number and Production number are indicated on the labels stuck on the rear cover. Specification label is attached on the frame.

NOTE: Always specify these numbers when inquiring about the generator or ordering spare parts in order to get correct parts and accurate service.

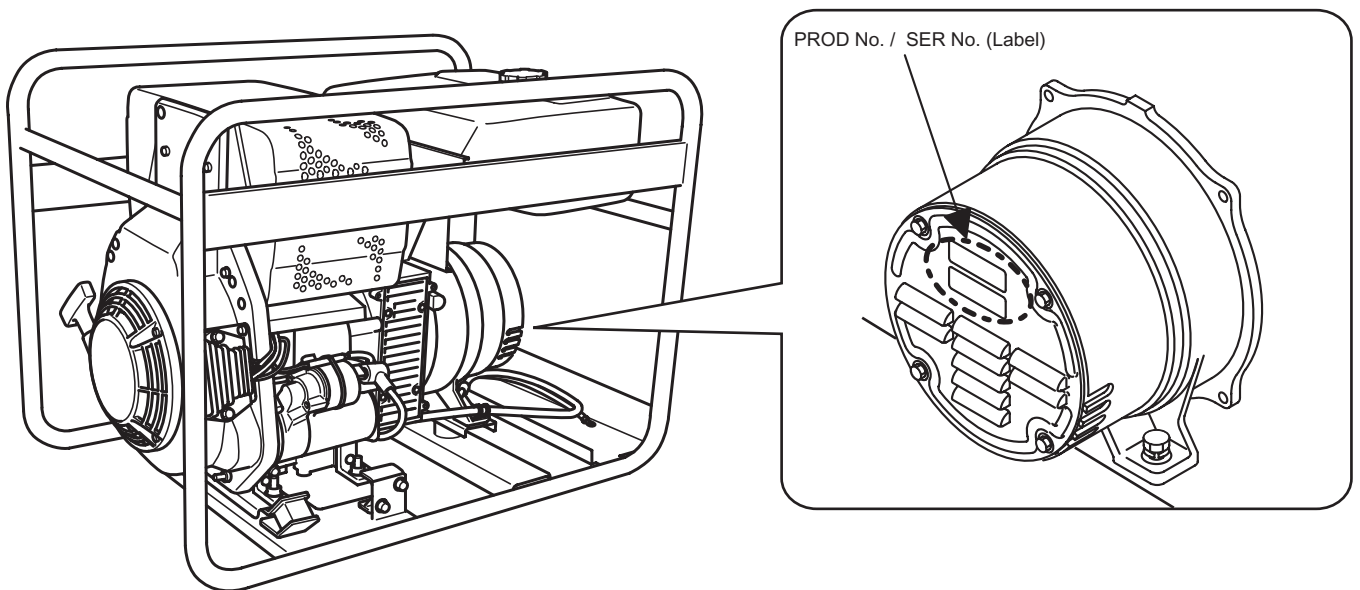

4. CONSTRUCTION AND FUNCTION

4-1 CONSTRUCTION

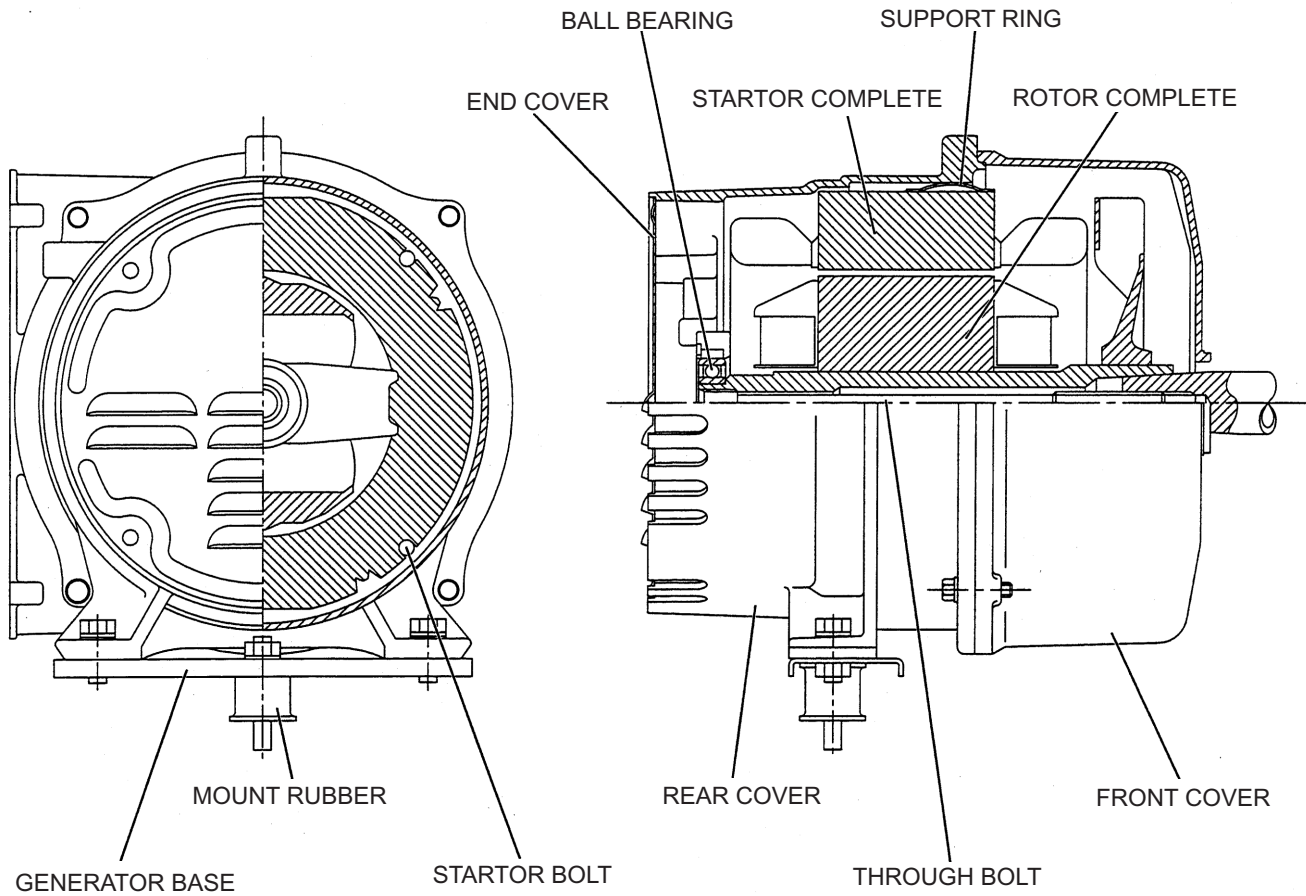

4-2 FUNCTION

4-2-1 STATOR

The stator consists of a laminated silicon steel sheet core, a main coil and a condenser coil which are wound in the core slots.

The condenser coil excites the rotor field coil which generates AC voltage in the main coil.

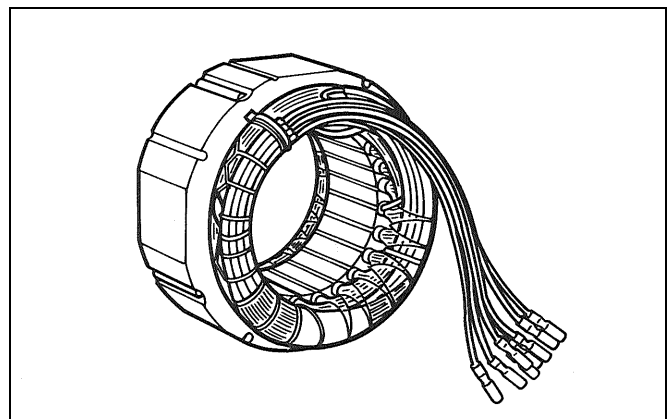

4-2-2 CONDENSER

Two condensers are installed in the control box and are connected to the condenser coil of the stator.

These condensers and condenser coil regulate the output voltage.

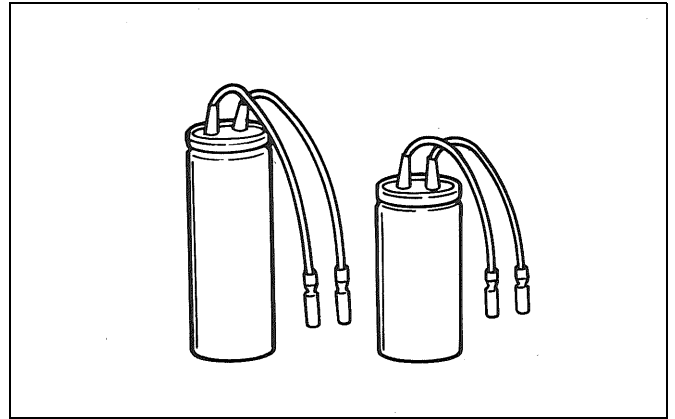

4-2-3 ROTOR

The rotor consists of a laminated silicon steel sheet core and a field coil which is wound over the core.

DC current in the field coil magnetizes the steel sheet core. Two permanent magnets are provided for the primary exciting action.

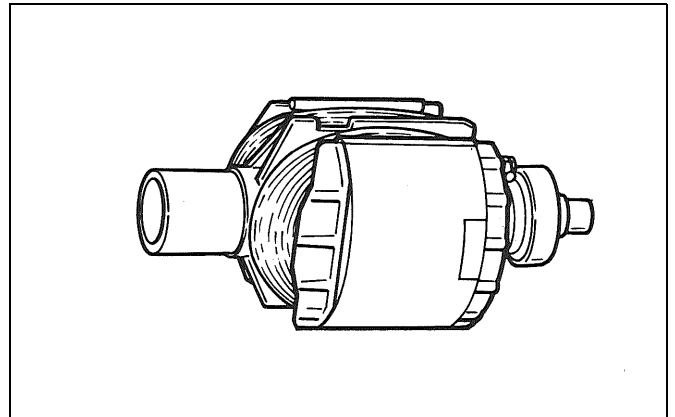

A diode rectifier and surge absorber is mounted inside of the insulator.

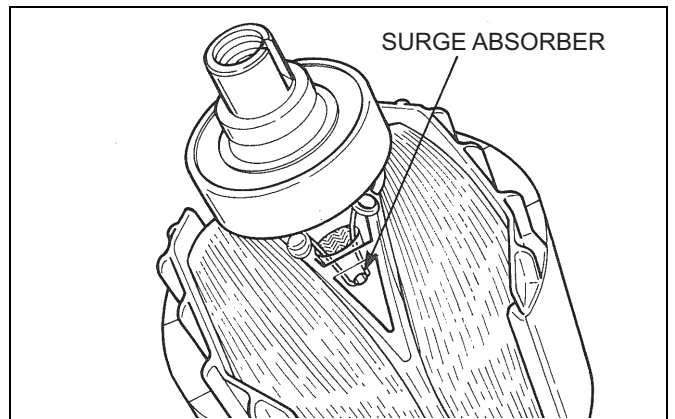
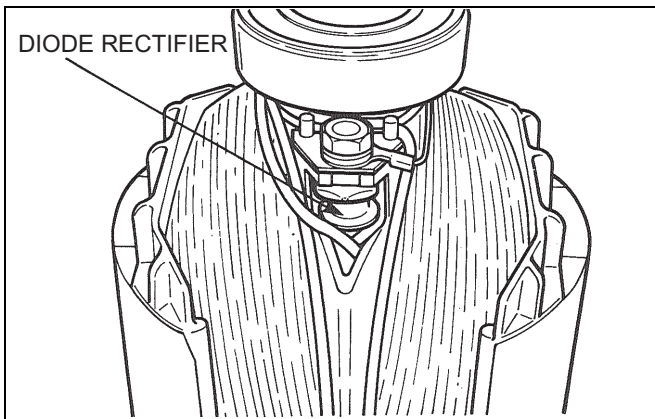

4-2-4 FUSE

The 10 ampere DC fuse mounted on the control panel protects whole DC circuit from getting damage by overload or short circuit.

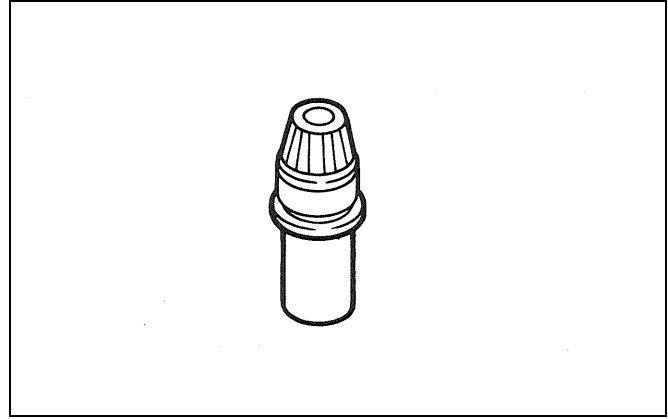

4-2-5 NO-FUSE BREAKER

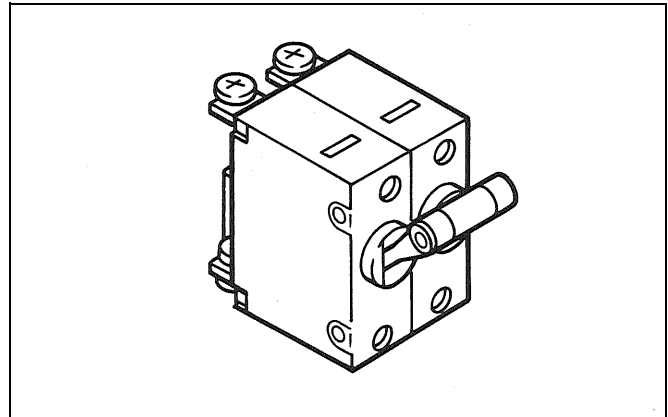

The no-fuse breaker protects the generator from getting damage by overloading or short circuit in the appliance. The table below shows the capacity of no-fuse breaker by each spec. and their object of protection.

MODEL	SPECIFICATION	NO-FUSE BREAKER	OBJECT of PROTECTION
RGD3300H	120/240 V	14 A × 2	Total output amperage
RGD5000H	120/240 V	20 A × 2	Total output amperage
		30 A	Output from 30 A receptacle

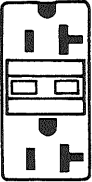

4-2-6 RECEPTACLE AND AC PLUG (STD. SPEC.)

These are used for taking AC output power from the generator. A total of three kinds of receptacles, each varying in rated voltage and current from another, are used to deliver the rated generator output. As many AC plugs as the receptacles, each matching the corresponding receptacle, are provided. The table below shows the rated current for each receptacle. Be careful not to use the receptacles and AC plugs beyond the specified limits to prevent burning.

Style	Ampere	Receptacle	AC plug	Description
	125 V 20 A	NEMA 5-20R	NEMA 5-20P	GFCI (Ground Fault Circuit Interrupter) Receptacle, duplex
	125 V/250 V 20 A	NEMA L14-20R	NEMA L14-20P	Locking Receptacle
	125 V 30 A	NEMA L5-30	NEMA L5-30P	Locking Receptacle

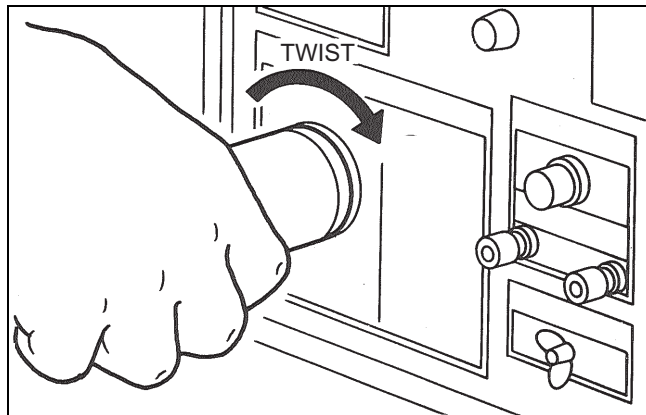

CAUTION: To connect the appliance to locking receptacle, insert the plug into the receptacle and turn it clockwise to lock.

NOTE: The generator for U.S.A. market is equipped with NEMA standard receptacles.
Use the proper plug for connecting appliance to the generator.

NOTE: If your generator has receptacles peculiar to your country, the table above does not apply.

4-3 GENERATOR OPERATION

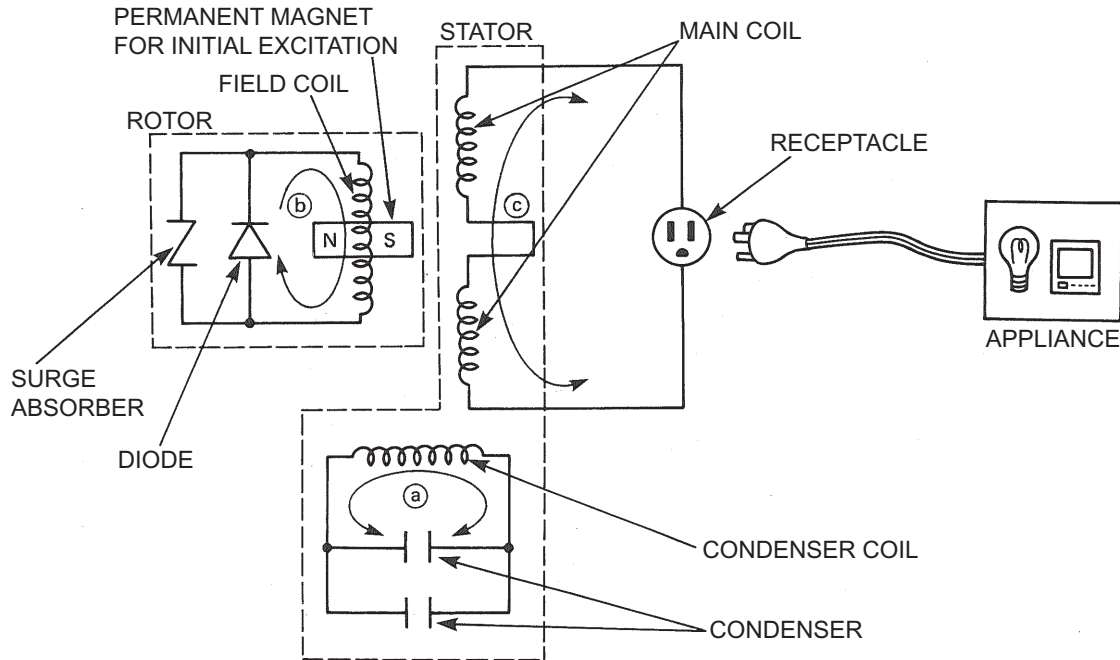

4-3-1 GENERATION OF NO-LOAD VOLTAGE

- (1) When the generator starts running, the permanent magnet built-in to the rotor generates 3 to 6 V of AC voltage in the main coil and condenser coil wound on the stator.
- (2) As two condensers are connected to the condenser coil, the small voltage at the condenser coil generates a minute current (a) which flows through the condenser coil. At this time, a small flux is produced with which the magnetic force at the rotor's magnetic pole is intensified. When this magnetic force is intensified, the respective voltages in the main coil and condenser coil rise up. As the current (a) increases, the magnetic flux at the rotor's magnetic pole increases further. Thus the voltages at the main coil and condenser coil keep rising by repeating this process.
- (3) As AC current flows through the condenser coil, the density of magnetic flux in the rotor changes. This change of magnetic flux induces AC voltage in the field coil, and the diode rectifier in the field coil circuit rectifies this AC voltage into DC. Thus a DC current flows through the field coil and magnetizes the rotor core to generate an output voltage in the main coil.
- (4) When generator speed reaches 3000 to 3300 rpm (60 Hz type), the current in the condenser coil and field coil increases rapidly. This acts to stabilize the output voltage of each coils. If generator speed further increases to the rated value, the generator output voltage will reach to the rated value.

4-3-2 VOLTAGE FLUCTUATIONS UNDER LOAD

When the output current (c) flows through the main coil to the appliance, a magnetic flux is produced and serves to increase current (a) in the condenser coil. When current (a) increases, the density of magnetic flux across the rotor core rises. As a result, the current flowing in the field coil increases and the generator output voltage is prevented from decreasing.

4-3-3 FULL POWER SWITCH (DUAL VOLTAGE TYPE)

The full power switch is provided for the dual voltage type to take out the full rated power from one receptacle in each voltage.

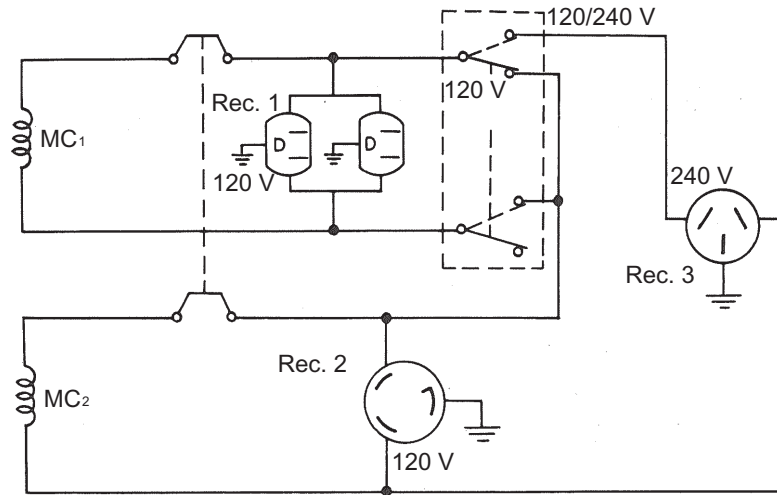

Fig. 1

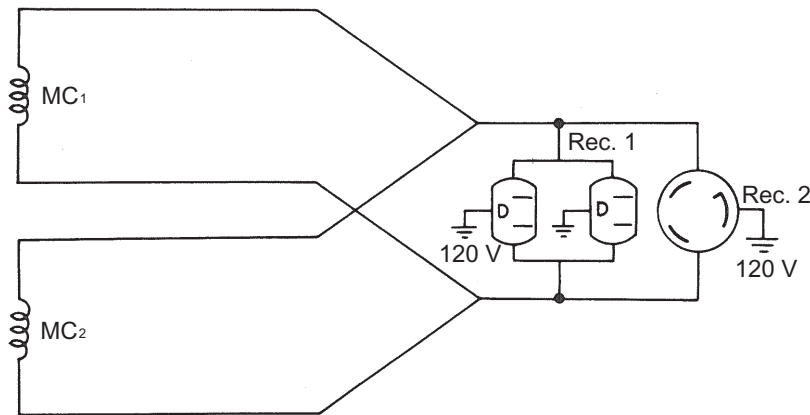

Fig. 2

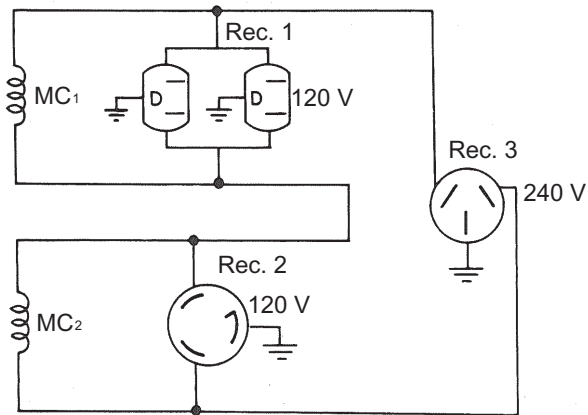

Fig. 3

Switch Position	LOWER VOLTAGE RECEPTACLE	HIGHER VOLTAGE RECEPTACLE
120 V	Rated output	No output can be taken.
120/240 V	Half of rated output	Rated output

Table A

Inside the generator are two sets of main coils. Each main coil outputs half the rated power at the lower voltage (120 V). These main coils are wound to be in the same phase. The full power switch reconnects these main coils in parallel or in series.

Fig. 1 shows a circuit diagram. When the full power switch is set for single lower voltage indication (120 V), the switch position is as indicated by the lower solid line in the diagram. Fig. 2 is a simplified representation of this circuit, showing the two main coils connected in parallel. In this case, the higher voltage (240 V) at Rec. 3 cannot be taken out. Rec. 2 for the lower voltage can output up to the rated power (up to 30 A if the rated current is over 30 A), and Rec. 1 can output up to a total of 15 A.

When the full power switch is set for double voltage indication (120 V/240 V), the switch position is as indicated by the upper dotted line in Fig. 1. Fig. 3 is a simplified representation of this circuit, showing the two main coils connected in series. In this case, power can be taken simultaneously from the receptacles for the both voltages. Rec. 3 for the higher voltage can output up to the rated power, but Rec. 1 and Rec. 2 for the lower voltage can output only up to half the rated power each.

Table A is a summary of the above explanation. Select the proper output voltage by full power switch in accordance with the appliance to be used.

4-3-4 VOLTAGE CHANGEOVER SWITCH

The generator of 50 Hz 110 V/220 V dual voltage type for U.K. is provided with voltage changeover switch instead of full power switch.

The output voltage is selected from 110 V and 220 V by turning this switch and both voltages cannot be taken out simultaneously.

The middle point of the main coil shall be grounded when the changeover switch is turned to 110 V side.

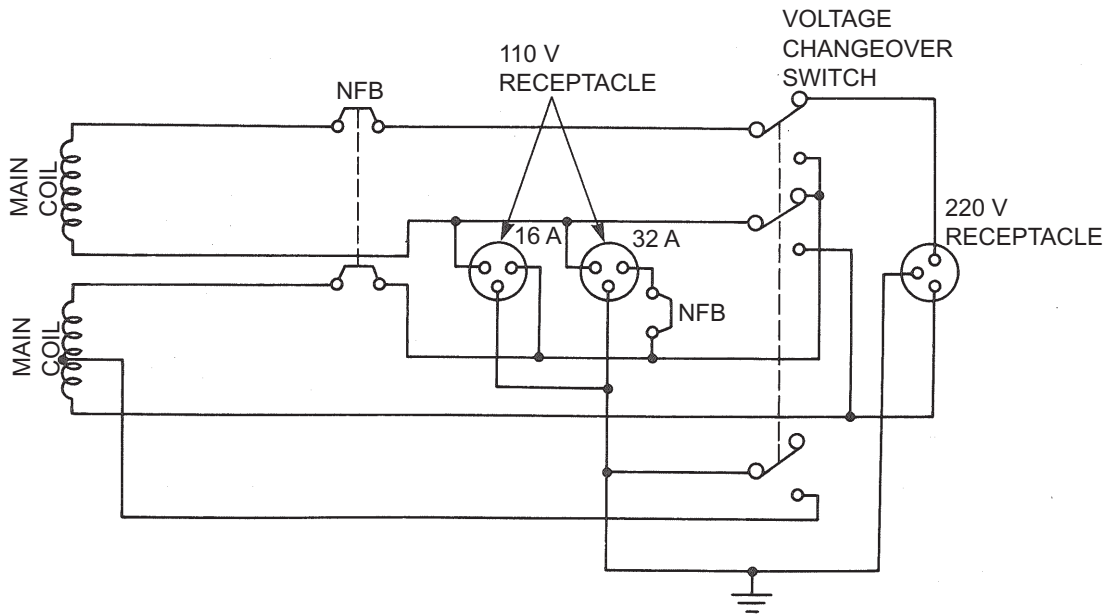

Fig. 4

5. SAFETY PRECAUTIONS

(1) Use extreme caution near fuel. A constant danger of explosion or fire exists.

Do not fill the fuel tank while the engine is running. Do not smoke or use open flame near the fuel tank.

Be careful not to spill fuel when refueling. If spilt, wipe it and let dry before starting the engine.

(2) Do not place inflammable materials near the generator.

Be careful not to put fuel, matches, gunpowder, oily cloth, straw, and any other inflammables near the generator.

(3) Do not operate the generator in a room, cave or tunnel. Always operate in a well-ventilated area.

Otherwise the engine may overheat and also, the poisonous carbon monoxide contained in the exhaust gases will endanger human lives. Keep the generator at least 1 m (4 feet) away from structures or facilities during use.

(4) Operate the generator on a level surface.

If the generator is tilted or moved during use, there is a danger of fuel spillage and a chance that the generator may tip over.

(5) Do not operate with wet hands or in the rain.

Severe electric shock may occur. If the generator is wet by rain or snow, wipe it and thoroughly dry it before starting.

Do not pour water over the generator directly nor wash it with water.

If the generator is wet with water, the insulations will be adversely affected and may cause current leakage and electric shock.

(6) Do not connect the generator to the commercial power lines.

This may cause a short-circuit or damage to the generator. Use a transfer switch for connecting with indoor wiring.

NOTE: The parts numbers of the transfer switches and of the plastic box to store them are as shown in the table below.

Part No.	Part Name	Q'ty	Phase	Allowable Current
365-45604-08	Transfer Switch	1	1	15 A
367-45605-08	Transfer Switch	1	1	30 A
340-45606-08	Transfer Switch	1	1	60 A
367-43008-08	Plastic Box	1	1	30 A
348-43009-08	Plastic Box	1	1	60 A

(7) Use a fuse of the correct capacity. (DC output)

If the generator rpm is increased excessively in the overload condition by using an over rated fuse, the generator may be burnt.

CAUTION: If the fuse is burnt out or the circuit breaker tripped off as a result of using an electrical appliance, the cause can be an overload or a short-circuit. In such a case, stop operation immediately and carefully check the electrical appliance and AC plugs for faulty wiring.

6. RANGE OF APPLICATIONS

Generally, the power rating of an electrical appliance indicates the amount of work that can be done by it. The electric power required for operating an electrical appliance is not always equal to the output wattage of the appliance. The electrical appliances generally have a label showing their rated voltage, frequency, and power consumption (input wattage). The power consumption of an electrical appliance is the power necessary for using it. When using a generator for operating an electrical appliance, the power factor and starting wattage must be taken into consideration.

In order to determine the right size generator, it is necessary to add the total wattage of all appliances to be connected to the unit.

Refer to the followings to calculate the power consumption of each appliance or equipment by its type.

(1) Incandescent lamp, heater, etc. with a power factor of 1.0

Total power consumption must be equal to or less than the rated output of the generator.

Example: A rated 3000 W generator can turn thirty 100 W incandescent lamps on.

(2) Fluorescent lamps, mercury lamps, etc. with a smaller power factor

Select a generator with a rated output equivalent to 1.2 to 2 times of the power consumption of the load.

Example: A 400 W mercury lamp requires 600 W to 700 W power source to be turned on.

A rated 3000 W generator can power four or five 400 W mercury lamps.

NOTE 1: *If a power factor correction capacitor is not applied to the mercury lamp or fluorescent lamp, the more power shall be required to drive those lamps.*

A rated 3000 W generator can drive one or two 400 W mercury lamps without power factor correction capacitors.

NOTE 2: *Nominal wattage of the fluorescent lamp generally indicates the output wattage of the lamp.*

Therefore, if the fluorescent lamp has no special indication as to the power consumption, efficiency should be taken into account as explained in Item (5) on the following page.

(3) Motor driven tools and light electrical appliances

Generally the starting wattage of motor driven tools and light electrical appliances are 1.2 to 3 times larger than their running wattage.

Example: A rated 250 W electric drill requires a 400 W generator to start it.

(4) Initially loaded motor driven appliances such as water pumps, compressors, etc.

These appliances require the large starting wattage which is 3 to 5 times of running wattage.

Example: A rated 900 W compressor requires a 4500 W generator to drive it.

NOTE 1: *Motor-driven appliances require the aforementioned generator output only at the starting.*

Once their motors are started, the appliances consume about 1.2 to 2 times their rated power consumption so that the excess power generated by the generator can be used for other electrical appliances.

NOTE 2: *Motor-driven appliances mentioned in Items (3) and (4) vary in their required motor starting power depending on the kind of motor and start-up load. If it is difficult to determine the optimum generator capacity, select a generator with a larger capacity.*

(5) Appliances without any indication as to power consumption

Some appliances have no indication as to power consumption; but instead the work load (output) is indicated. In such a case, power consumption is to be worked out according to the numerical formula mentioned below.

$$\frac{\text{(Output of electrical appliance)}}{\text{(Efficiency)}} = \text{(Power consumption)}$$

Efficiencies of some electrical appliances are as follows:

Single-phase motor	0.6 ~ 0.75	} — The smaller the motor, the lower the efficiency.
Three-phase motor	0.65 ~ 0.9	
Fluorescent lamp	0.7 ~ 0.8	

Example 1: A 40 W fluorescent lamp means that its luminous output is 40 W. Its efficiency is 0.7 and accordingly, power consumption will be $40 \div 0.7 = 57$ W. As explained in **Item (2)**, multiply this power consumption value of 57 W by 1.2 ~ 2 and you will get the figure of the necessary capacity of a generator. In other words, a generator with a rated output of 1000 W capacity can light nine to fourteen 40 W fluorescent lamps.

Example 2: Generally speaking, a 400 W motor means that its work load is 400 W. Efficiency of this motor is 0.7 and power consumption will be $400 \div 0.7 = 570$ W. When this motor is used for a motor-driven tool, the capacity of the generator should be multiplied by 1.2 to 3 and 570 W as explained in the **Item (3)**.

MODEL	RGD3300H	RGD5000H
Frequency	60 Hz	60 Hz
Incandescent lamp, heater, etc.	3,300 W	4,500 W
Fluorescent lamp, mercury lamp, etc.	approx. 2,200 W	approx. 3,000 W
Motor-driven tool, general-purpose motor, etc.	approx. 1,900 W	approx. 2,700 W
Water pump, compressor, etc.	approx. 950 W	approx. 1,300 W

NOTES: Wiring between generator and electrical appliances

1. Allowable current of cable

Use a cable with an allowable current that is larger than the rated input current of the load (electrical appliance). If the input current is larger than the allowable current of the cable used, the cable will become excessively heated and deteriorate the insulation, possibly burning it out.

The table below shows cables and their allowable currents for your reference.

2. Voltage drop in long electric extension cords

When a long wire is used to connect an appliance with the generator, a certain amount of voltage drop occurs in the wire which lessens effective voltage available to the appliance. The table below has been prepared to illustrate the approximate voltage loss when an extension cord of 300 feet (approx. 100 meters) is used to connect an appliance or tool to the generator.

Nominal cross section	A.W.G. Gauge No.	Allowable current	No. of strands/strand dia.	Resistance	Current Amp.							Voltage drop
					1 A	3 A	5 A	8 A	10 A	12 A	15 A	
mm ²	No.	A	No./mm	Ω/100 m	1 A	3 A	5 A	8 A	10 A	12 A	15 A	
0.75	18	7	30/0.18	2.477	2.5	8 V	12.5 V	—	—	—	—	
1.27	16	12	50/0.18	1.486	1.5 V	5 V	7.5 V	12 V	15 V	18 V	—	
2.0	14	17	37/0.26	0.952	1 V	3 V	5 V	8 V	10 V	12 V	15 V	
3.5	12 ~ 10	23	45/0.32	0.517	—	1.5 V	2.5 V	4 V	5 V	6.5 V	7.5 V	
5.5	10 ~ 8	35	70/0.32	0.332	—	1 V	2 V	2.5 V	3.5 V	4 V	5 V	

Voltage drop indicates as $V = \frac{1}{100} \times R \times I \times \ell$

R means resistance (Ω/100 m) on the above table.

I means electric current through the wire (A).

ℓ means the length of the wire (m).

The length of the wire indicates round length, it means twice the length from generator to electrical tools.

7. MEASURING PROCEDURES

7-1 MEASURING INSTRUMENTS

7-1-1 VOLTMETER

AC voltmeter is necessary. The approximate AC voltage ranges of the voltmeters to be used for various types of generators are as follows:

0 to 150 V: Type with an output voltage of 120 V

0 to 300 V: Type with an output voltage of 240 V

0 to 150 V, 0 to 300 V: Dual voltage type

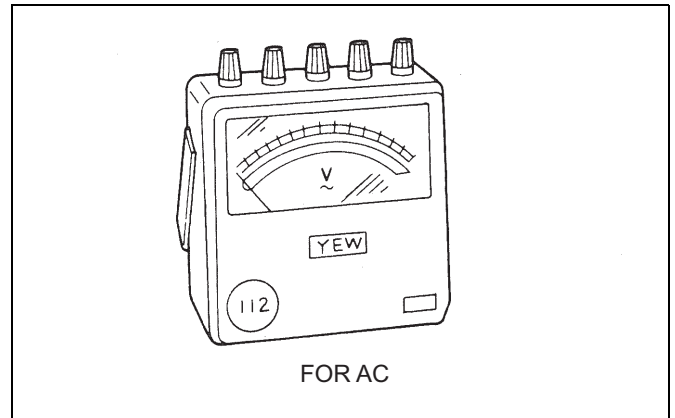

7-1-2 AMMETER

AC ammeter is necessary. An AC ammeter with a range that can be changed according to the current rating of a given generator is most desirable. (About 10 A, 20 A, 100 A)

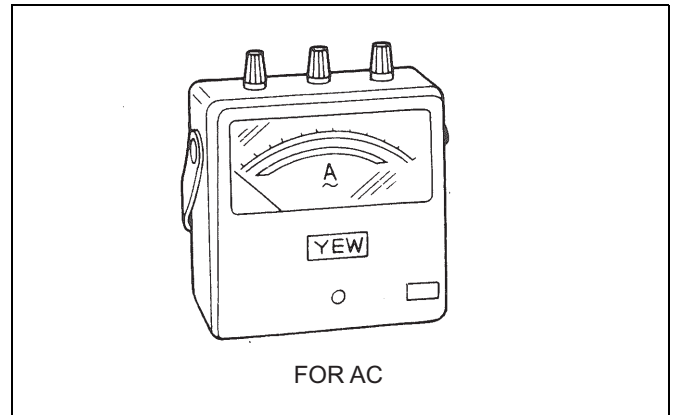

7-1-3 FREQUENCY METER

Frequency range: About 45 to 65 Hz

NOTE: Be careful of the frequency meter's input voltage range.

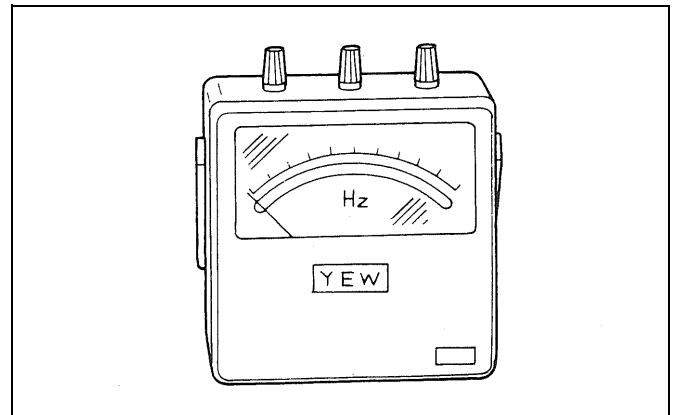

7-1-4 TESTER

Used for measuring resistance, etc.

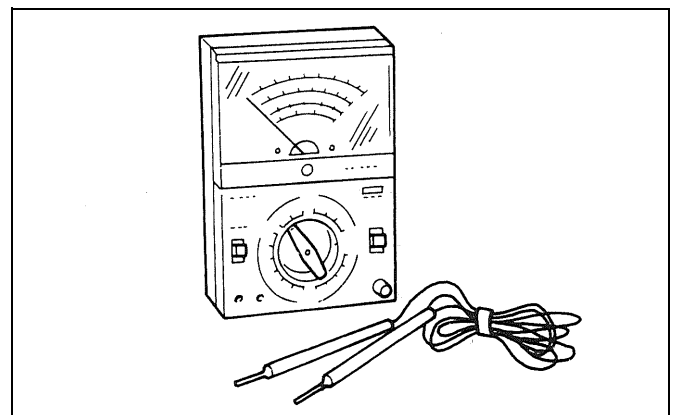

7-1-5 MEGGER TESTER

Used for measuring generator insulation resistance.

Select one with testing voltage range of 500 V.

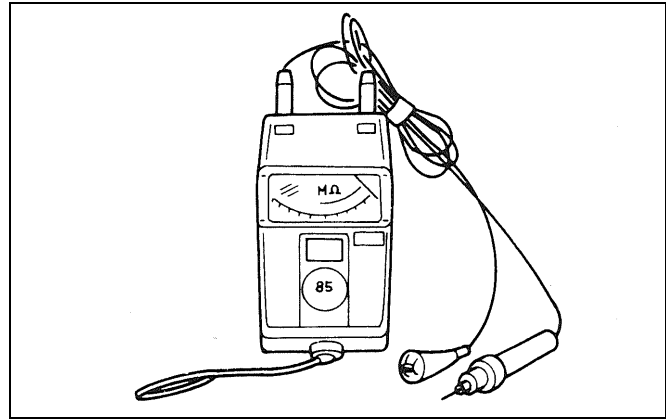

7-1-6 TACHOMETER

There are various types of tachometers, such as contactless type, contact type, and strobe type. The contact type can be used only when the generator and engine have been disassembled. The contactless type is recommended.

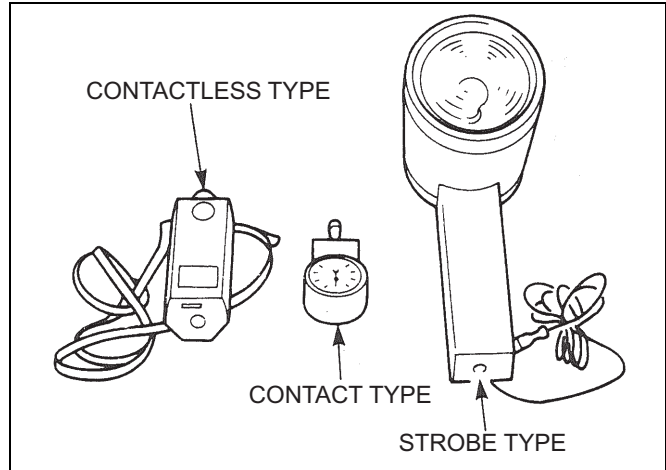

7-2 AC OUTPUT MEASURING

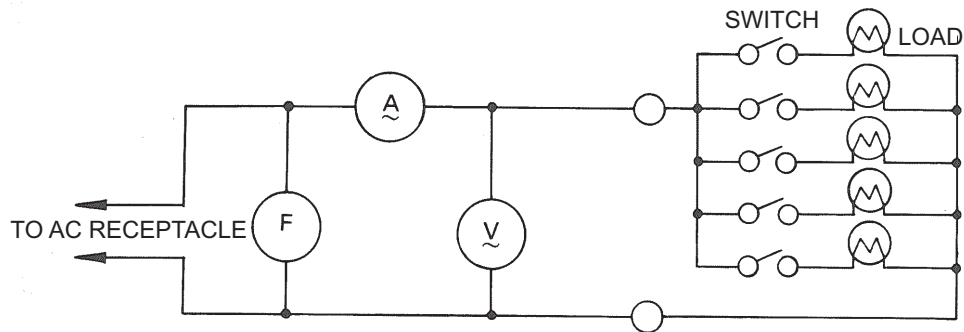

Use a circuit like the one shown in the figure above for measuring AC output. A hot plate or lamp with a power factor of 1.0 may be used as a load. Adjust the load and rpm, and check that the voltage range is as specified in the table below at the rated amperage and rated rpm.

Rated voltage	120 V	240 V
Voltage range	117 ~ 130 V	235 ~ 260

7-3 MEASURING INSULATION RESISTANCE

● CONTROL PANEL

Connect a megger tester to one of receptacle output terminals and the ground terminal, then measure the insulation resistance.

An insulation resistance of 1 megohm or more is normal. (The original insulation resistance at the time of shipment from the factory is 10 megohms or more.)

If it is less than 1 megohm, disassemble the generator and measure the insulation resistance of the stator, rotor and control panel individually.

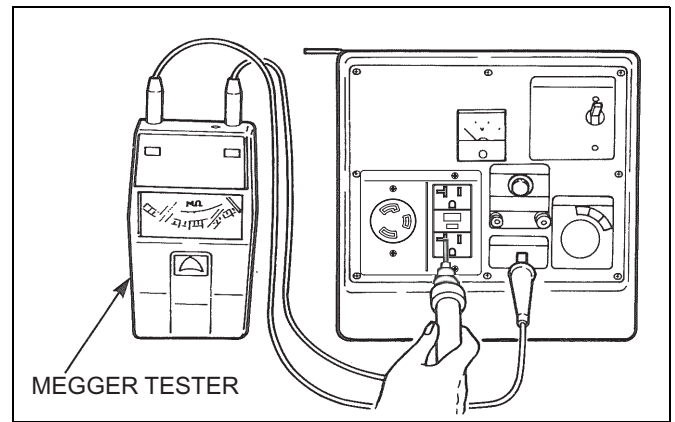

● STATOR

- (1) Measure the insulation resistance between BLUE lead and the core.
- (2) Measure the insulation resistance between WHITE lead and the core.
- (3) Measure the insulation resistance between YELLOW lead and the core.
- (4) Measure the insulation resistance between BROWN lead and the core.

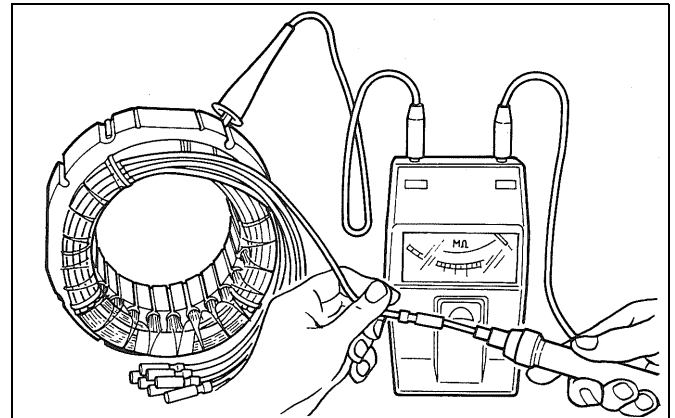

● ROTOR

Measure the insulation across one of the soldered terminals of the rotor and the core.

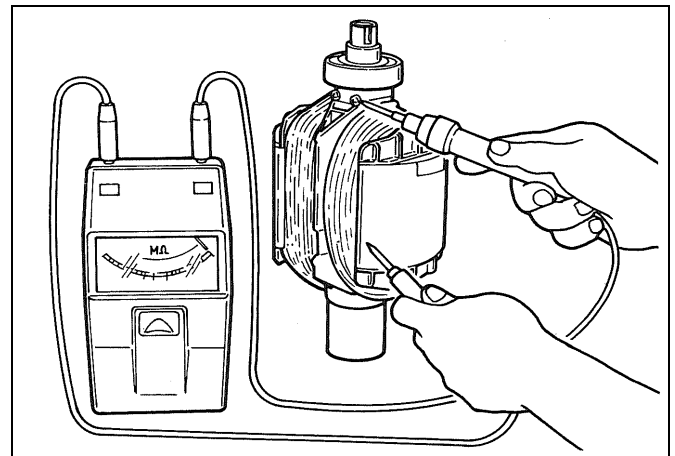

Any part where the insulation resistance is less than 1 MΩ has faulty insulation, and may cause electric leakage and electric shock.

Replace the faulty part.

8. CHECKING FUNCTIONAL MEMBERS

8-1 AC RECEPTACLES

Using a circuit tester, check continuity between the two terminals at the rear of the AC receptacles while the receptacle is mounted on the control panel. When continuity is found between the output terminals of the receptacle with a wire connected across these terminals, the AC receptacle is normal. When the wire is removed and no continuity is found between these terminals, the receptacles are also normal.

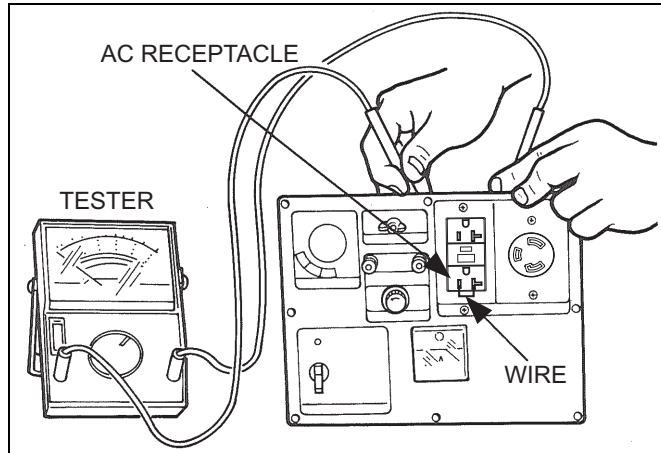

Front

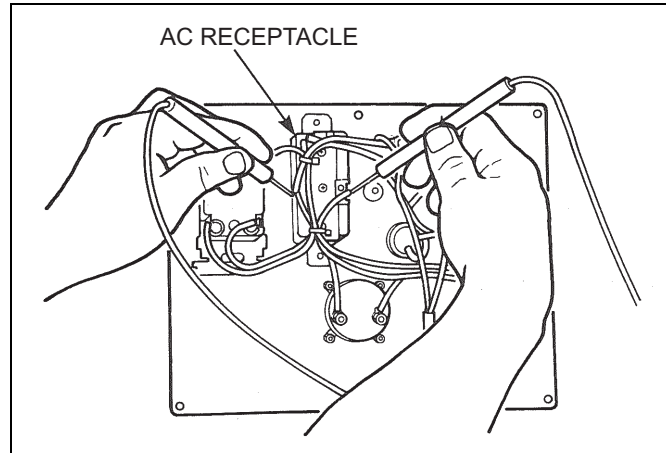

Rear

8-2 CIRCUIT BREAKER

Check continuity between each of two terminals at the rear of the circuit breaker while it is mounted on the control panel.

Normally, there is continuity between each of the two when the circuit breaker is on while there is no continuity when the circuit breaker is off.

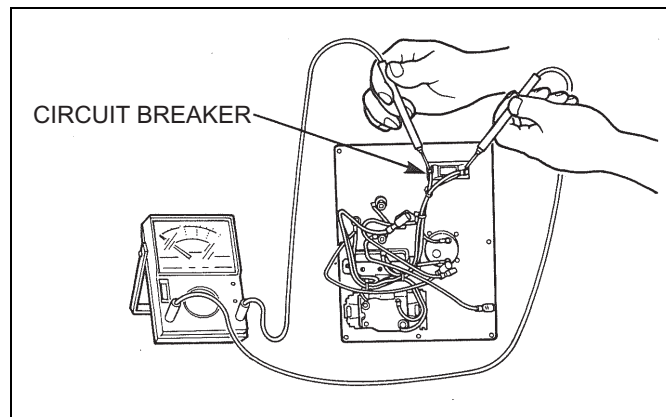

8-3 STATOR

Disengage connectors on the wires from stator and check the resistance between wires with a circuit tester referring to the following table.

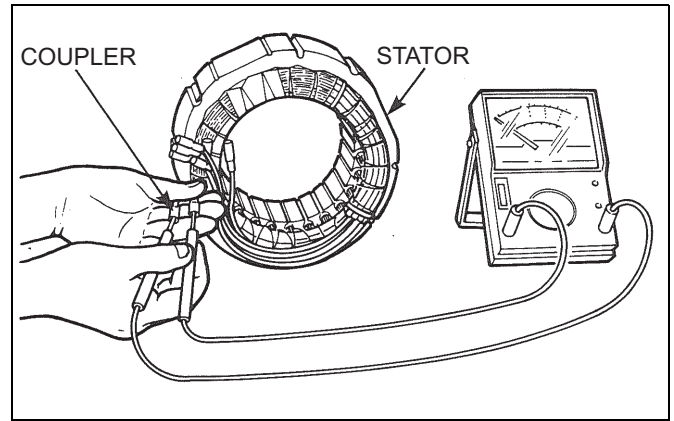

(R × 1 Ω ±10%)

MODEL	SPECIFICATION		AC Winding		Condenser Winding	DC Winding
	Hz	Voltage	White-Red	Black-Blue	Yellow-Yellow	Brown-Brown
RGD3300H	60	120 V 120 V/240 V	0.48	0.48	0.92	0.17
RGD5000H	60	240 V 120 V/240 V	0.23	0.23	0.54	0.13

NOTE: If the circuit tester is not sufficiently accurate, it may not show the values given and may give erroneous readings.

Erroneous readings will also occur when there is a wide variation of resistance among coil windings or when measurement is performed at ambient temperatures different from 20°C (68°F).

8-4 ROTOR ASSEMBLY

- Using the circuit tester, measure the resistance of the field coil.

(R × 1 Ω ±10%)

MODEL	RGD3300H	RGD5000H
Resistance	2.1 Ω	1.6 Ω

NOTE 1: Measure the resistance of each coil winding while the diode and each resistor are disconnected with their solder removed.

NOTE 2: If the circuit tester is not sufficiently accurate, it may not show the values given and may give erroneous readings.

Erroneous reading will also occur when there is a wide variation of resistance among coil windings or when measurement is performed at ambient temperatures different from 20°C (68°F).

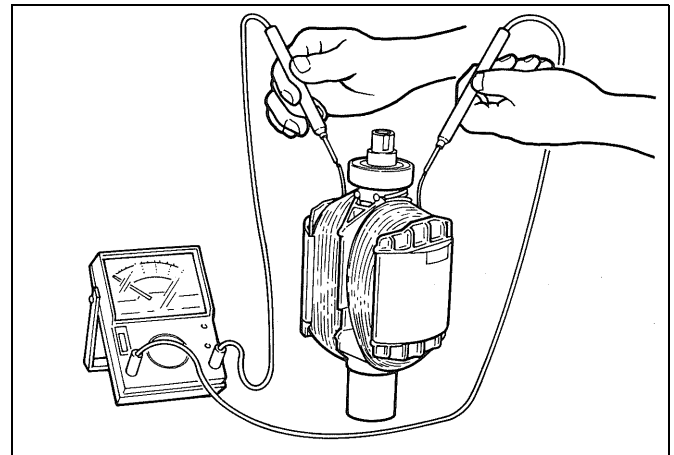

- (2) Check if the surge absorber is burnt.
Check the resistance of surge absorber.

Normal resistance is $\infty \Omega$.

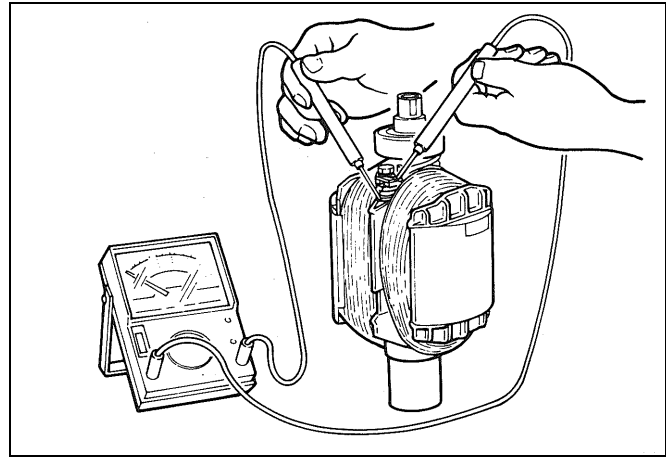

- (3) Measure the resistance of the diode.

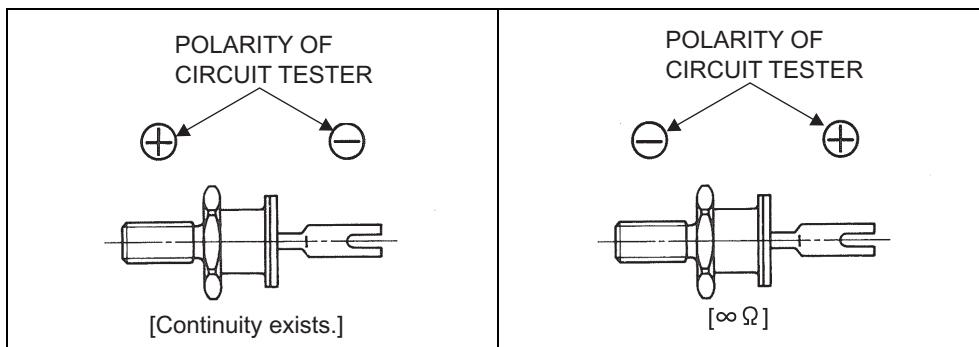

8-5 CONDENSER

- If an instrument (QC-meter or C-meter) for measuring capacity of condenser is available, check the capacity of condenser.

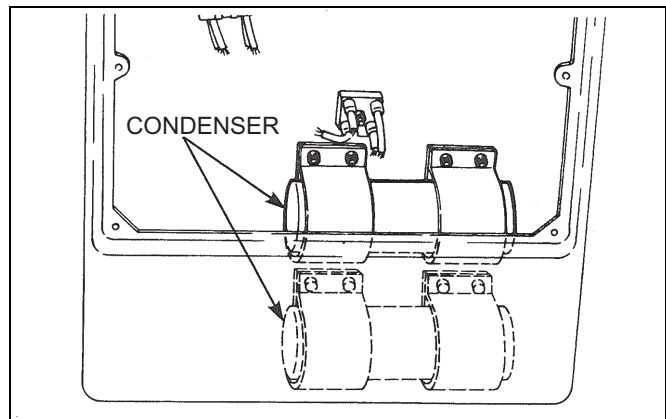

NORMAL CAPACITY OF CONDENSER			
MODEL		RGD3300H	RGD5000H
		60 Hz	60 Hz
CONDENSER	①	20 μF	30 μF
	②	20 μF	30 μF

- If such an instrument is unavailable, the condenser can be checked by replacing with a new one. If the generator performs good with new condenser, the cause of trouble is defect in original condenser.

8-6 DIODE RECTIFIER

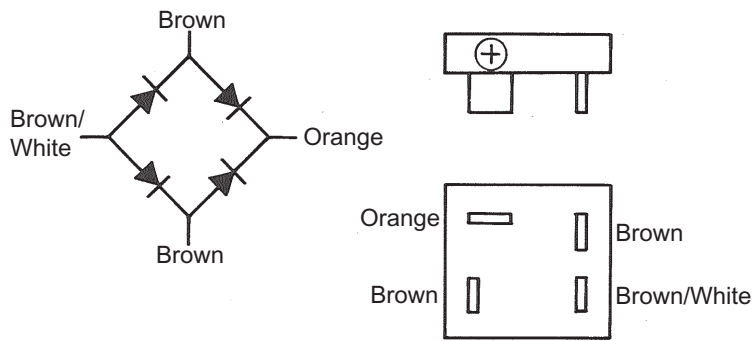

Fig. 5

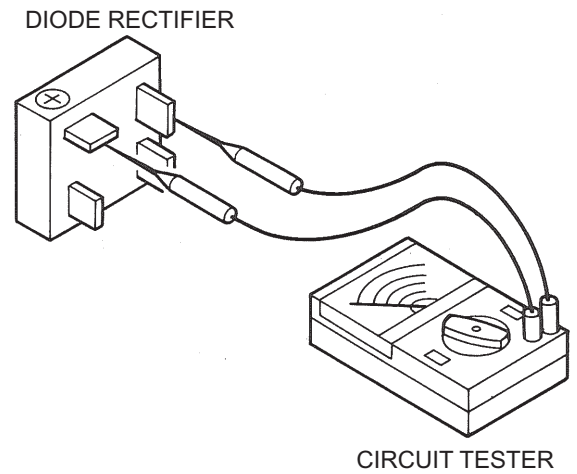

Fig. 6

Circuit inside of the diode rectifiers is as shown in Fig. 5. Check continuity between each terminal by using a circuit tester as shown in Fig. 6. The rectifier is normal when continuity is as follows:

		Apply black \ominus needle of the circuit tester			
		Brown	Brown	Orange	Brown/White
Apply red \oplus needle of the circuit tester	Brown		No continuity	No continuity	Continuity
	Brown	No continuity		No continuity	Continuity
	Orange	Continuity	Continuity		Continuity
	Brown/White	No continuity	No continuity	No continuity	

NOTE 1: In checking the diode, direction of connection is contrary to the ordinary case because of characteristics of the diode and battery incorporated in the tester.

NOTE 2: "Continuity" means forward direction characteristics of the diode, and different from short circuit condition (in which a pointer of the tester goes out of its normal scale), shows resistance to some extent. When results of the checking indicates failure even in one section, replace with a new one.

9. DISASSEMBLY AND ASSEMBLY

9-1 PREPARATION AND PRECAUTIONS

- (1) Be sure to memorize the location of individual parts when disassembling the generator so that the generator can be reassembled correctly. Tie tags noted with the necessary information to facilitate easier and smoother reassembly.
- (2) For more convenience, divide the parts into several groups and store them in boxes.
- (3) To prevent bolts and nuts from being misplaced or installed incorrectly, place them temporarily back at their original position.
- (4) Handle disassembled parts with care; clean them before reassembly using a neutral cleaning fluid.
- (5) Use all disassembly/assembly tools properly, and use the proper tool for each specific job.

9-2 SPECIAL TOOLS FOR DISASSEMBLY AND ASSEMBLY

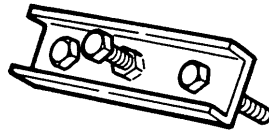

REAR COVER PULLER
388-95001-07

9-3 DISASSEMBLY PROCEDURES

Step	Part to remove	Description	Remarks	Tool
1	Fuel Tank	(1) Close fuel cock.	Draining tank of fuel before disassembly is unnecessary.	
		(2) Remove the fuel cock from the bracket (6 ϕ flange bolt).		
		(3) Remove the hose clamps (three places).		Plier
		(4) Loosen the four nuts (8 ϕ) and remove the fuel tank.	Take care of spilt fuel from the fuel tank.	10 mm spanner or box spanner
		(5) Remove the fuel tank mount. (4 places)		

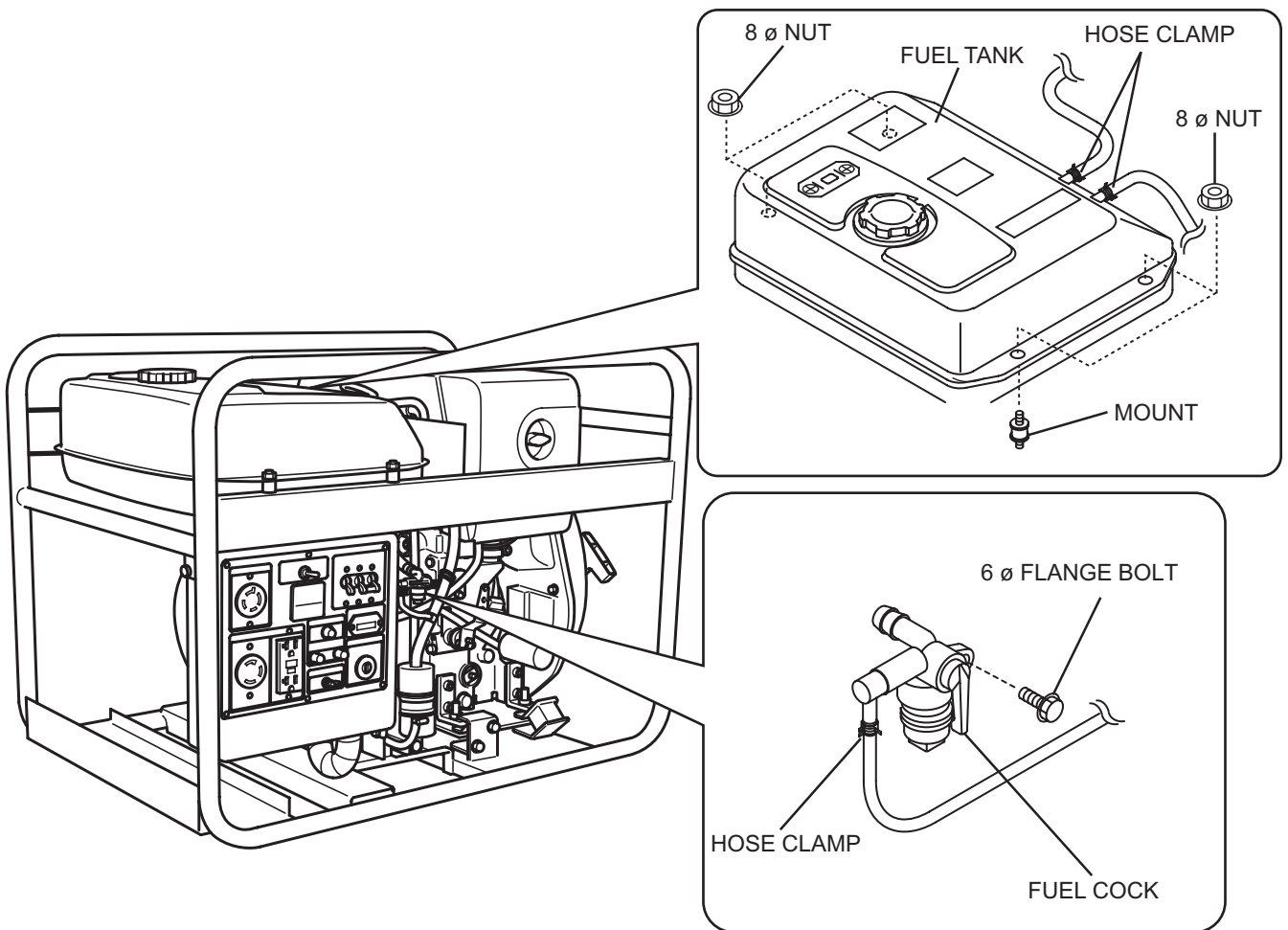

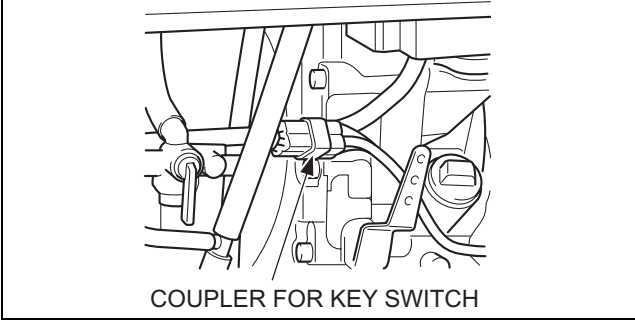
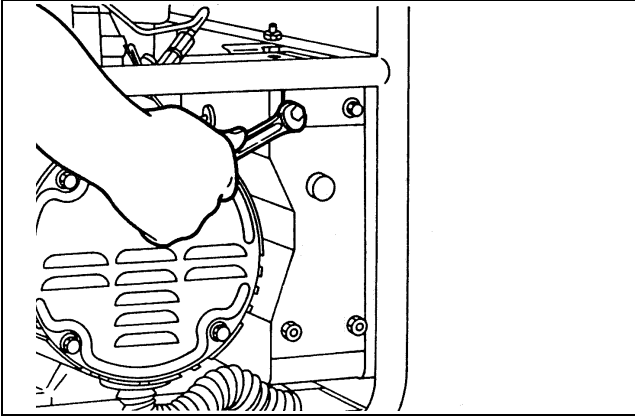
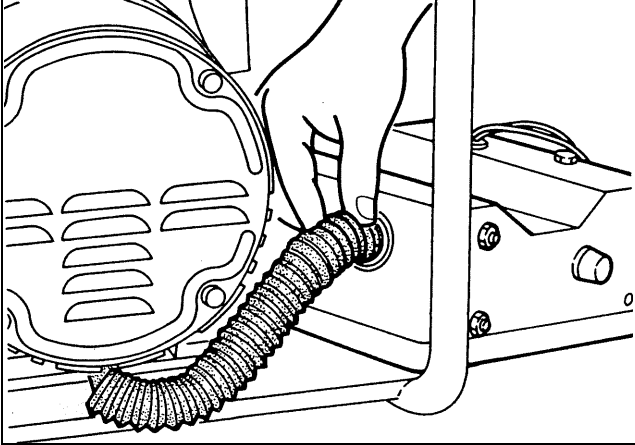
Step	Part to remove	Description	Remarks	Tool
2	Control Box	<p>(1) Disconnect the coupler for key switch.</p>  <p style="text-align: center;">COUPLER FOR KEY SWITCH</p>		
		<p>(2) Remove control box from frame by removing the three bolts (6 \emptyset) joining the control box to frame and side plate.</p> 	Wire harness is still connected.	10 mm spanner or box spanner
		<p>(3) Put the control box with control panel down.</p>	Put a waste cloth under the control panel to protect it.	10 mm spanner
		<p>(4) Loosen the nut (4 \emptyset) to remove the ground wire (green/yellow) from the rear of control box.</p>		
		<p>(5) Pull the bushing out from the control box.</p> 		

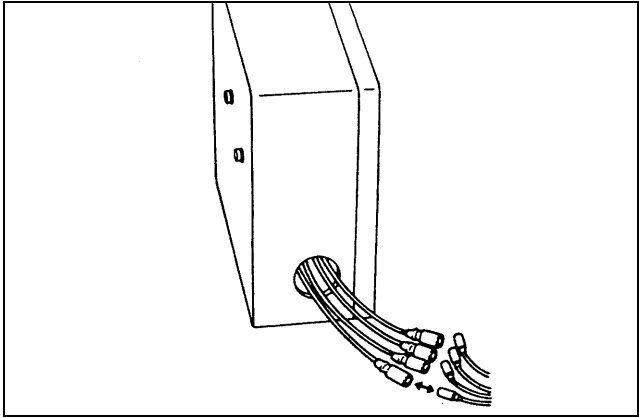
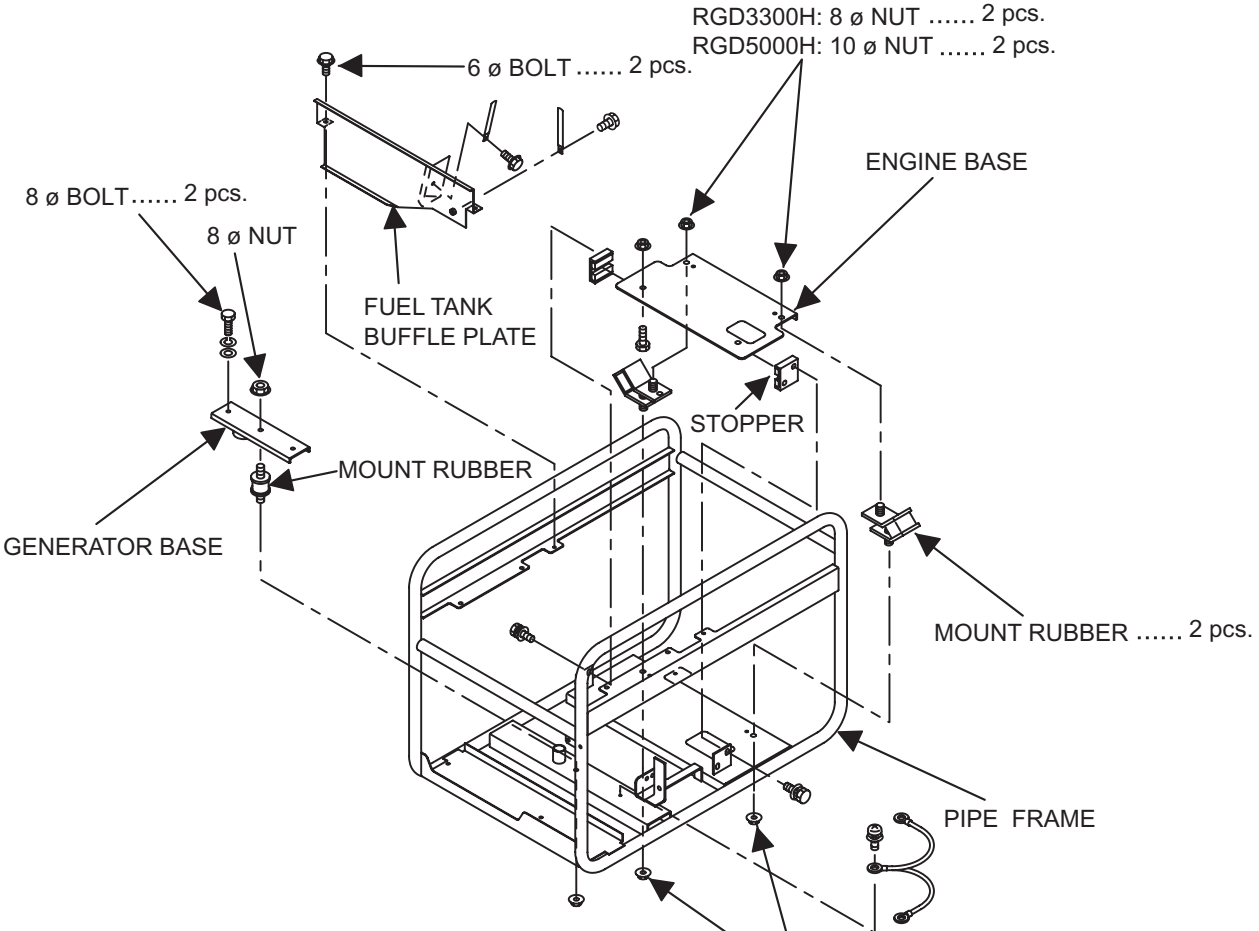
Step	Part to remove	Description	Remarks	Tool
2	Control Box	<p>(6) Pull the wire harness out from the control box. Disengage the connectors to separate the control box.</p> 		
3	Pipe Frame	 <p>RGD3300H: 8 \emptyset NUT 2 pcs. RGD5000H: 10 \emptyset NUT 2 pcs.</p> <p>6 \emptyset BOLT 2 pcs.</p> <p>8 \emptyset BOLT 2 pcs. 8 \emptyset NUT</p> <p>ENGINE BASE</p> <p>FUEL TANK BUFFLE PLATE</p> <p>STOPPER</p> <p>MOUNT RUBBER</p> <p>GENERATOR BASE</p> <p>MOUNT RUBBER 2 pcs.</p> <p>PIPE FRAME</p> <p>RGD3300H: 8 \emptyset NUT 2 pcs. RGD5000H: 10 \emptyset NUT 2 pcs.</p>		

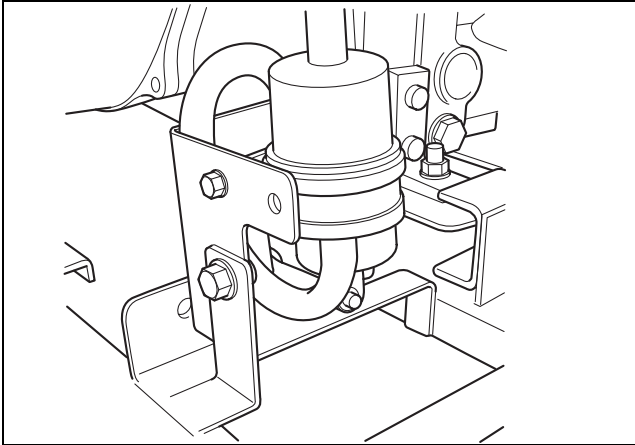
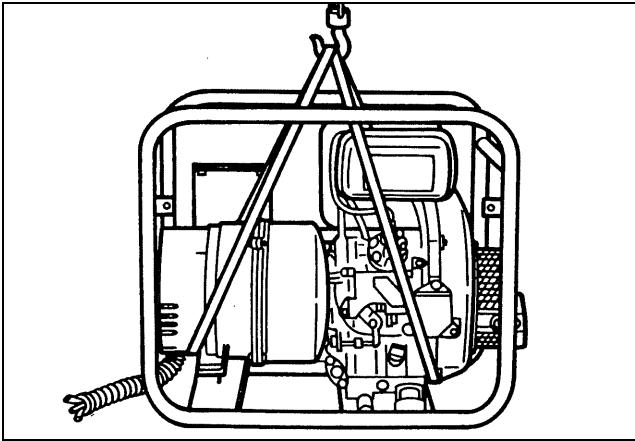
Step	Part to remove	Description	Remarks	Tool	
3	Pipe Frame	(1) Remove the fuel tank baffle plate. 6 ø bolts 2 pcs.			
		(2) Remove the stoppers. 8 ø bolts 4 pcs.		10 mm spanner or box spanner	
		(3) Remove the filter bracket from the frame. 8 ø bolts 2 pcs.	Take care of spilt fuel from the filter.		
					
		(4) Remove the four nuts which join the mount rubbers to the engine.		12 mm spanner	
		(5) Remove the two bolts which join the rear cover to the generator base. 8 ø bolt 2 pcs.		12 mm spanner	
		(6) Remove the bolts and nuts to fix the engine base.			
		(7) Lift up the engine and alternator assembly using a chain-block, and dis- mount it from frame.			
					
(8) Remove generator base from mount rubber. 8 ø nut 1 pc.		12 mm spanner			
(9) Remove mount rubbers from frame.		12 mm spanner			

Step	Part to remove	Description	Remarks	Tool
4	Rear Cover	(1) Remove end cover from rear cover. 6 ϕ bolt..... 4 pcs.		10 mm spanner or box wrench
		(2) Remove through bolt from rotor shaft. Apply a socket wrench on the head of through bolt and hit the wrench handle with a hammer counterclockwise to loosen.		RGD3300H: 14 mm RGD5000H: 14 mm Box wrench
		(3) Remove the four bolts which join the rear cover to the front cover.		
		(4) Take off the rear cover. Use the special tool "REAR COVER PULLER" to remove the rear cover. a. Insert the two bolts of the special tool into the thread holes of the rear cover. b. Apply the center bolt of the special tool to the center hole of the rotor shaft. c. Tighten the center bolt to pull out the rear cover.	Insert the two bolts sufficiently and evenly, or the thread holes may be damaged at removing.	

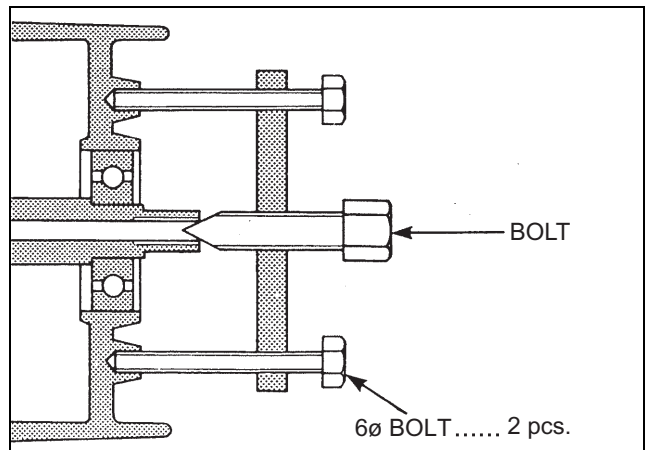
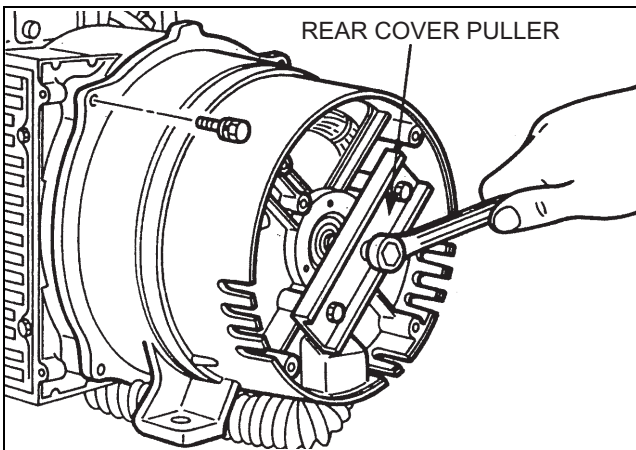
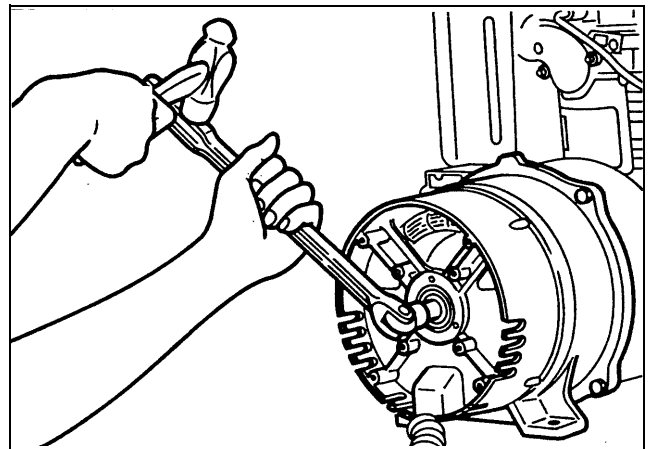
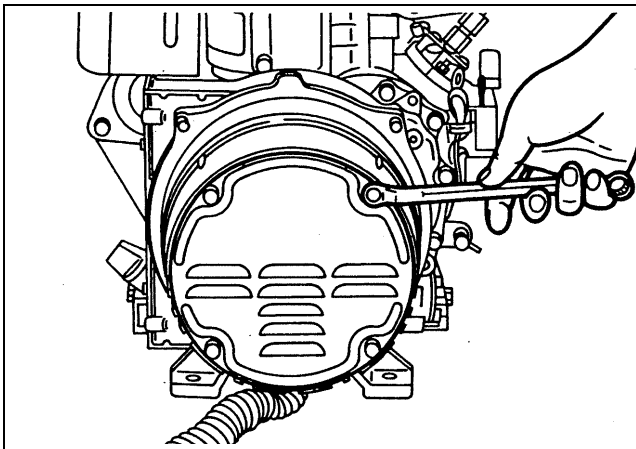

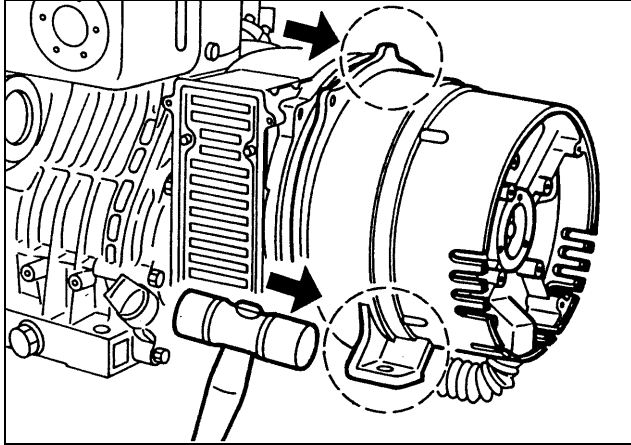
Step	Part to remove	Description	Remarks	Tool
4	Rear Cover	<p>In case that "REAR COVER PULLER" is unavailable, remove the rear cover by the following instructions:</p> <ol style="list-style-type: none"> Insert the through bolt into the rotor shaft and tighten lightly. Hit on the boss at the top of the rear cover and two legs evenly with a plastic hammer to remove. 	Do not give a strong hit on the rear cover boss or legs.	Plastic hammer
5	Stator	<ol style="list-style-type: none"> Remove the four bolts which join the stator to rear cover. Insert a small hook into the hole inside of the support ring and pull it out. <ul style="list-style-type: none"> If a small hook is unavailable, remove the stator by the following procedure: <ol style="list-style-type: none"> Hold the rear cover and stator assembly open side down. Place a cushion under the stator to protect it when dropped. Hit on the bearing housing of rear cover with a wooden block. 	Be careful not to give a damage to the stator winding.	10 mm box wrench

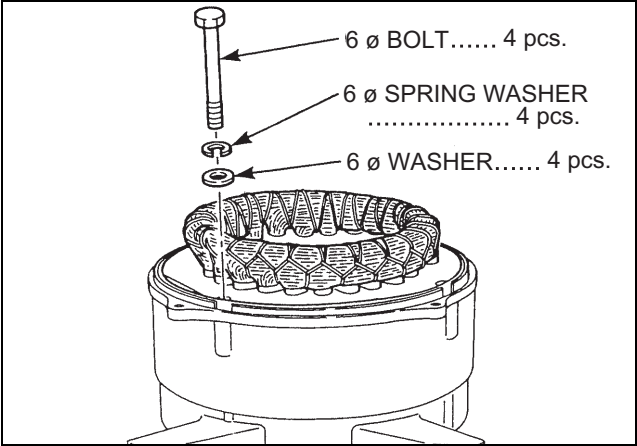

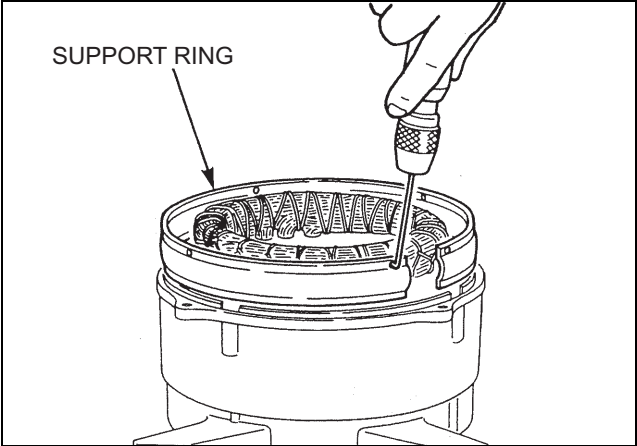

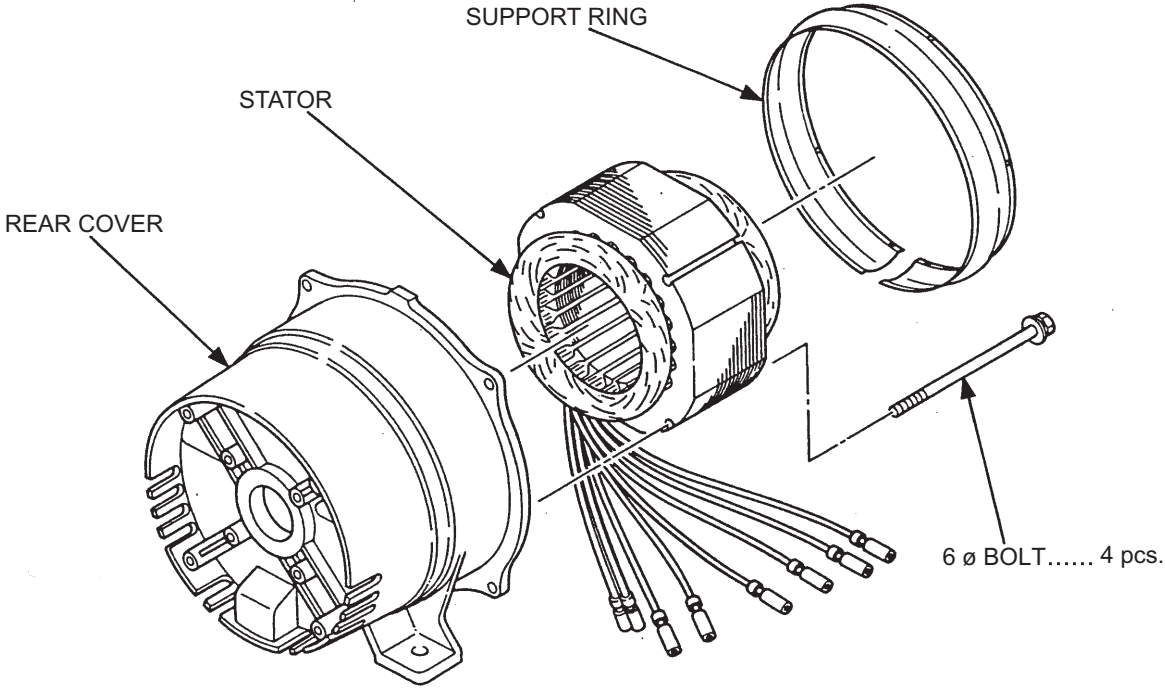
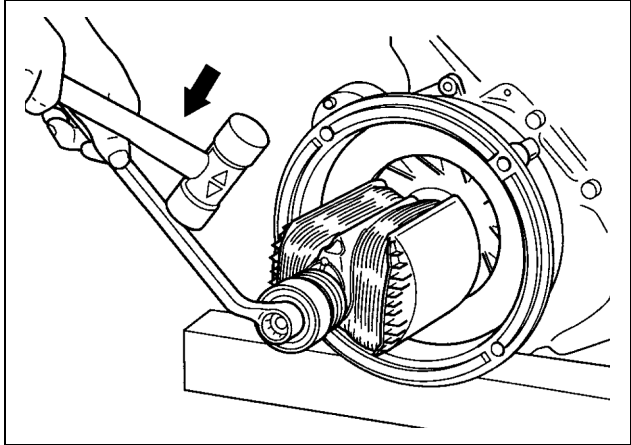
Step	Part to remove	Description	Remarks	Tool
5	Stator	<p>(3) Pull out the wires from rear cover.</p> 		
6	Rotor	<p>(1) Take off the through bolt. Apply a box wrench on the head of through bolt. Hit the wrench handle with a hammer counter-clockwise to loosen.</p>  <p>(2) Put the engine on the working table recoil starter side down.</p>		<p>Box wrench Plastic hammer</p>

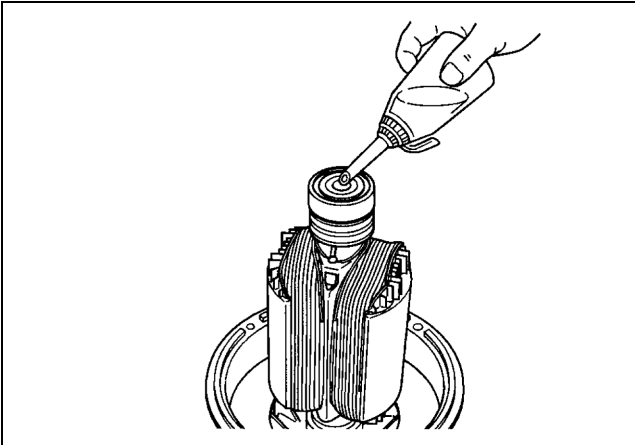
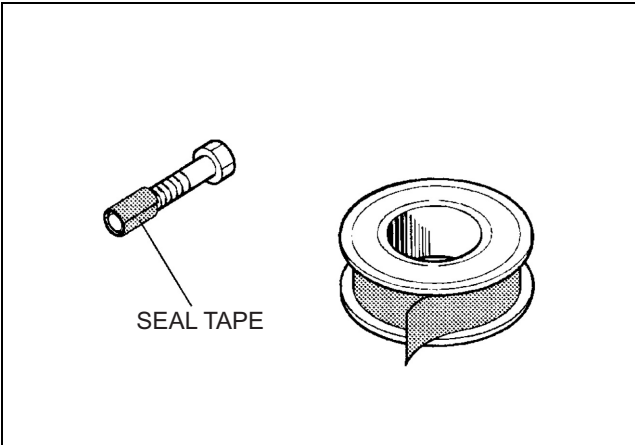
Step	Part to remove	Description	Remarks	Tool
6	Rotor	<p>(3) Use a bolt and oil as a tool for pulling out rotor in the following procedures:</p> <ol style="list-style-type: none"> 1. Pour engine oil into the center hole of rotor shaft. Fill with oil to the shaft end.  <ol style="list-style-type: none"> 2. Prepare a bolt with the following thread size: M12 × P1.5 3. Apply a few turns of seal tape around the tip of the bolt.  <ol style="list-style-type: none"> 4. Screw the bolt into the thread of the rotor shaft. 	<p>Do not stick out your face over the rotor.</p>	

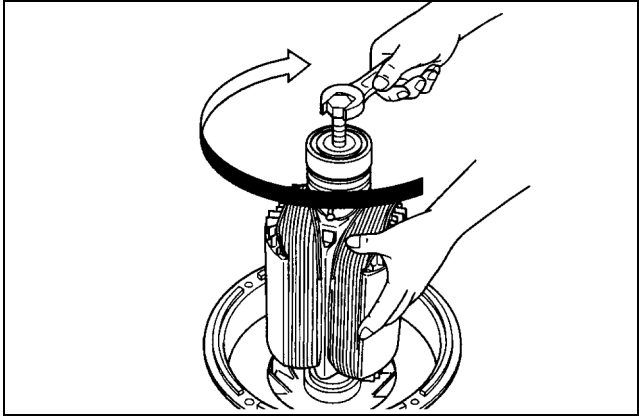
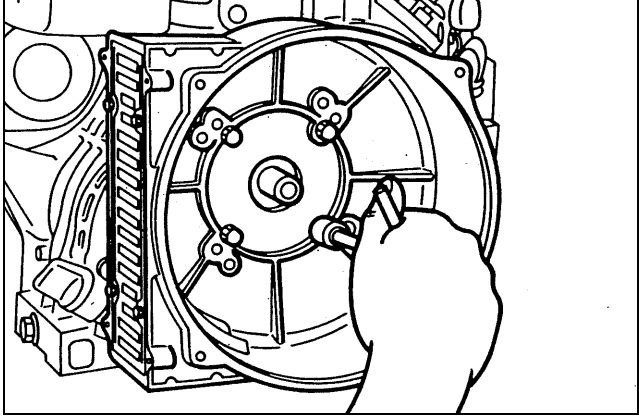
Step	Part to remove	Description	Remarks	Tool
6	Rotor	<p>5. Torque the bolt using a socket wrench until the rotor comes off loose.</p>  <p>* The hydraulic pressure inside the rotor shaft takes apart the rotor from the engine shaft.</p> <p>(4) Wipe off oil thoroughly from rotor shaft and engine PTO shaft.</p>	It may jump up on separation.	Socket wrench
7	Front cover and Front Protector	<p>(1) Remove the four bolts which join the front cover to the engine. 8 ø bolt..... 4 pcs.</p> <p>(2) Remove front protector from front cover.</p> 		<p>12 mm spanner</p> <p>8 mm spanner or screw driver (+)</p>

9-4 ASSEMBLY PROCEDURES

9-4-1 FRONT PROTECTOR AND FRONT COVER

- (1) Attach the front protector to front cover.
The louvers of the front protector project into the inside of front cover.

5 ϕ × 10 mm Tapping screw..... 4 pcs.

Tightening torque: 3.4 ~ 5.4 N-m (35 ~ 55 kg-cm, 2.5 ~ 4 ft-lb)

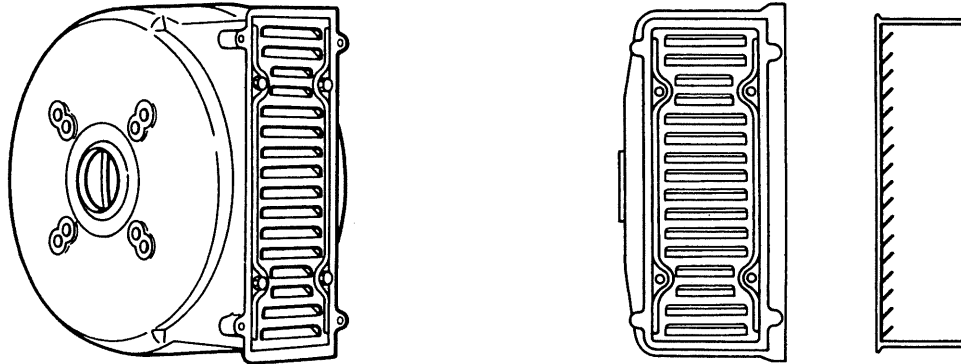

- (2) Install the front cover to the engine. Apply thread locking agent (Loctite 221 or Threebond 1342N) to the bolt as shown by the arrow without fail.

8 ϕ × 20 mm bolt and washer assy
..... 4 pcs.

Tightening torque: 11.8 ~ 13.7 N-m (120 ~ 140 kg-cm, 8.68 ~ 10.1 ft-lb)

NOTE 1: *Insufficient thread locking agent application could cause oil leakage.*

NOTE 2: *The size of faucet joint and pitch of mounting holes of front cover is different by models RGD3300H and RGD5000H.*

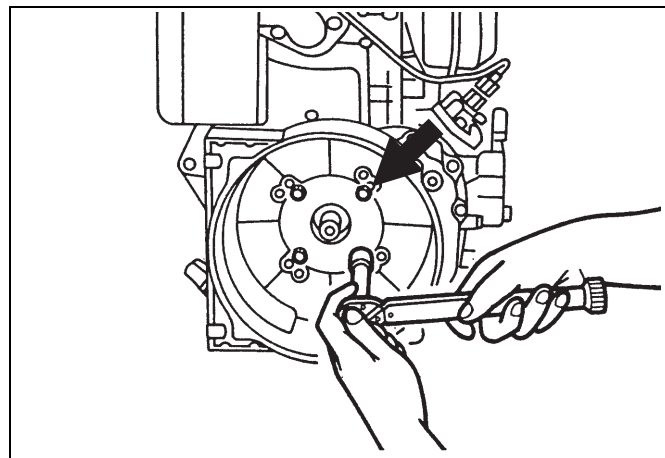

9-4-2 ROTOR

- (1) Clean the tapered portion of driving shaft and the matching tapered hole of rotor shaft of oil and dirt using a waste cloth.

- (2) Attach rotor to the driving shaft.
Tighten through bolt with washer and spring washer.

Tightening torque: 22.6 ~ 24.5 N-m (230 ~ 250 kg-cm, 16.6 ~ 18.1ft-lb)

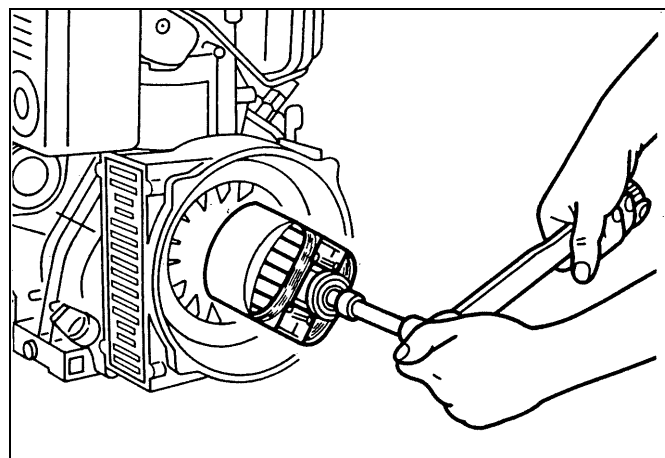

9-4-3 STATOR AND REAR COVER

- (1) Set the stator on the jig.
Match the grooves of the stator with the grooves of the jig.
- (2) Attach the support ring around the stator setting the open ends of the ring to the position of stator leads.
Check that the hooking holes are placed at the flat sides of the stator.
- (3) Insert four guide bolts into the bolt holes of the rear cover and mount it on the stator matching the guide bolts with the grooves of the stator.
Tighten the guide bolts tentatively.
- (4) Take the stator leads out from the window of the rear cover.
- (5) Put a board on the rear cover and press it using a pressing machine.
If a pressing machine is unavailable, tap around the board on the rear cover evenly with a plastic hammer to press fit the rear cover over the stator.

CAUTION: Take care of the rear cover to be pressed in upright position.

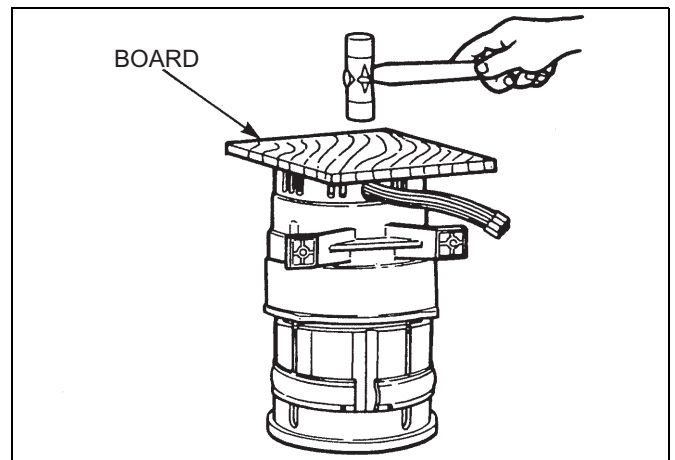
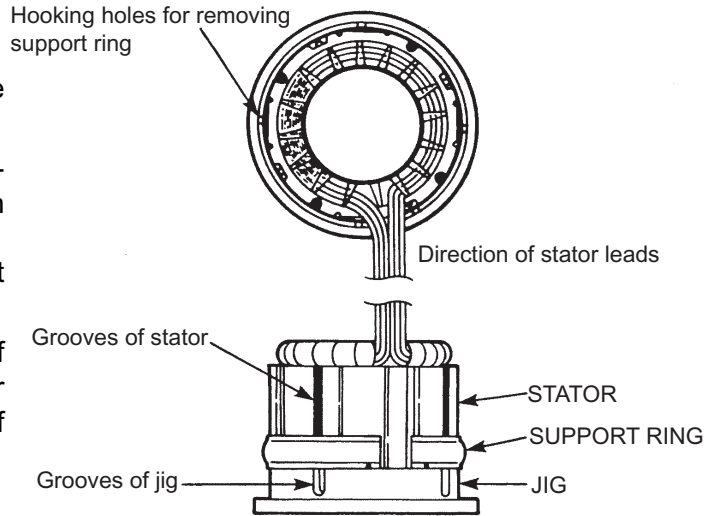

- (6) Join the stator to rear cover with four bolts, washers and spring washers.

- 6 \emptyset bolt 4 pcs.
- 6 \emptyset washer 4 pcs.
- 6 \emptyset spring washer..... 4 pcs.

Tightening torque: 7.8 ~ 9.8 N-m (80 ~ 100 kg-cm, 5.8 ~ 7.2 ft-lb)

NOTE: Tighten four bolts evenly taking several steps.

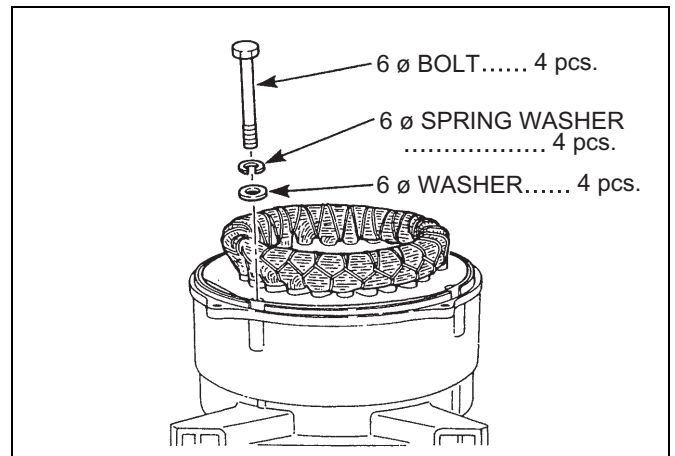

● The dimensions of the stator bolts are shown in the table below.

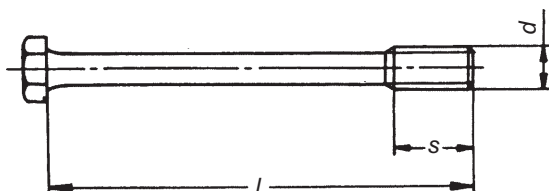

Model		<i>l</i>	<i>s</i>	<i>d</i>
RGD3300H	(mm)	85	25	6
	(inch)	3.35	0.99	0.24
RGD5000H	(mm)	115	25	6
	(inch)	4.53	0.99	0.24

- (7) Attach the boot over the lead wires drawn out from the rear cover. Press the smaller end of boot into the rear cover.

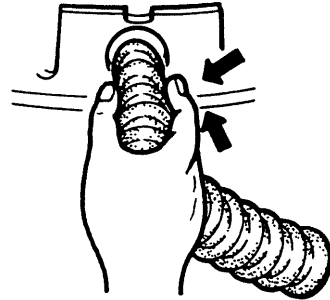
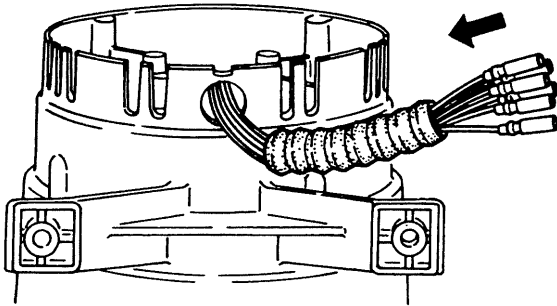

- (8) Put the rear cover and stator assembly over the rotor. Tap on the rear cover evenly with a plastic hammer to press the rotor bearing into the rear cover.

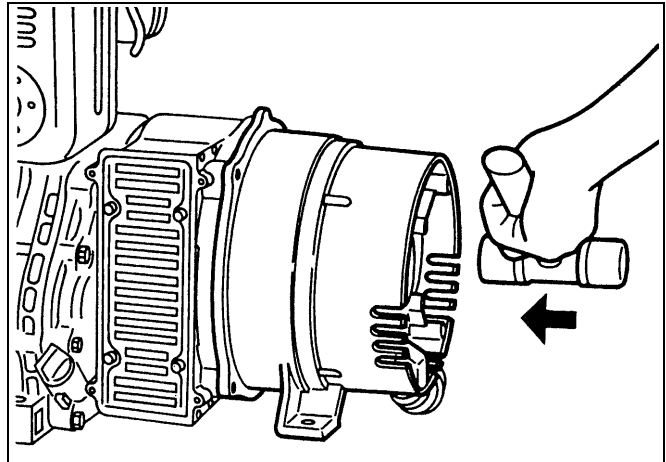

- (9) Tighten the four bolts, washers and spring washers to join the rear cover to the front cover.

- 6 ϕ \times 25 mm bolt..... 4 pcs.
 - 6 ϕ wash 4 pcs.
 - 6 ϕ spring washer 4 pcs.
- Tightening torque: 4.9 ~ 5.9 N-m (50 ~ 60 kg-cm, 3.6 ~ 4.3 ft-lb)

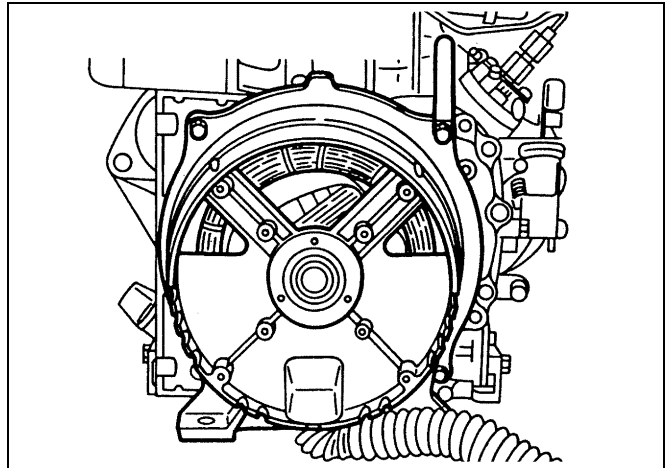

9-4-4 END COVER

Attach end cover to the rear cover.

The air-inlets of the end cover have to face downward.

- 6 ϕ \times 8 mm flange bolt..... 4 pcs.
- Tightening torque: 3.9 ~ 5.9 N-m (40 ~ 60 kg-cm, 2.9 ~ 4.3 ft-lb)

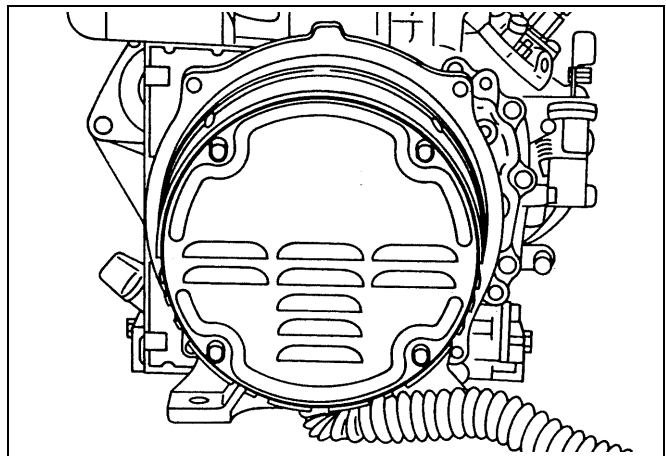

9-4-5 PIPE FRAME

- (1) Attach two mount rubbers for the engine base onto the frame.

Tighten the nuts from the bottom side of the frame.

8 ϕ flange nut 2 pcs.

Tightening torque: 11.8 ~ 13.7 N-m (120 ~ 140 kg-cm, 8.68 ~ 10.1 ft-lb)

- (2) Attach the 5 ϕ terminal of grounding wires (green/yellow) to the unpainted thread hole of the frame base plate using a 5 mm brass screw.

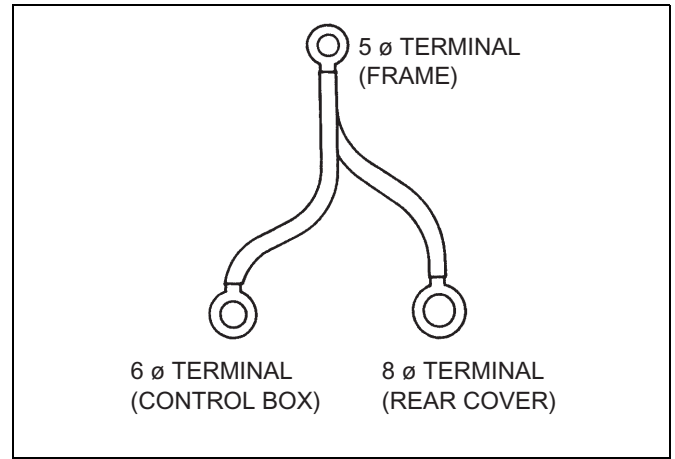

- (3) Attach the generator mount rubber to the frame.

NOTE: The mount rubbers are selected to reduce vibration most effectively by model and its frequency.

Be sure to use the correct mount rubber for your generator.

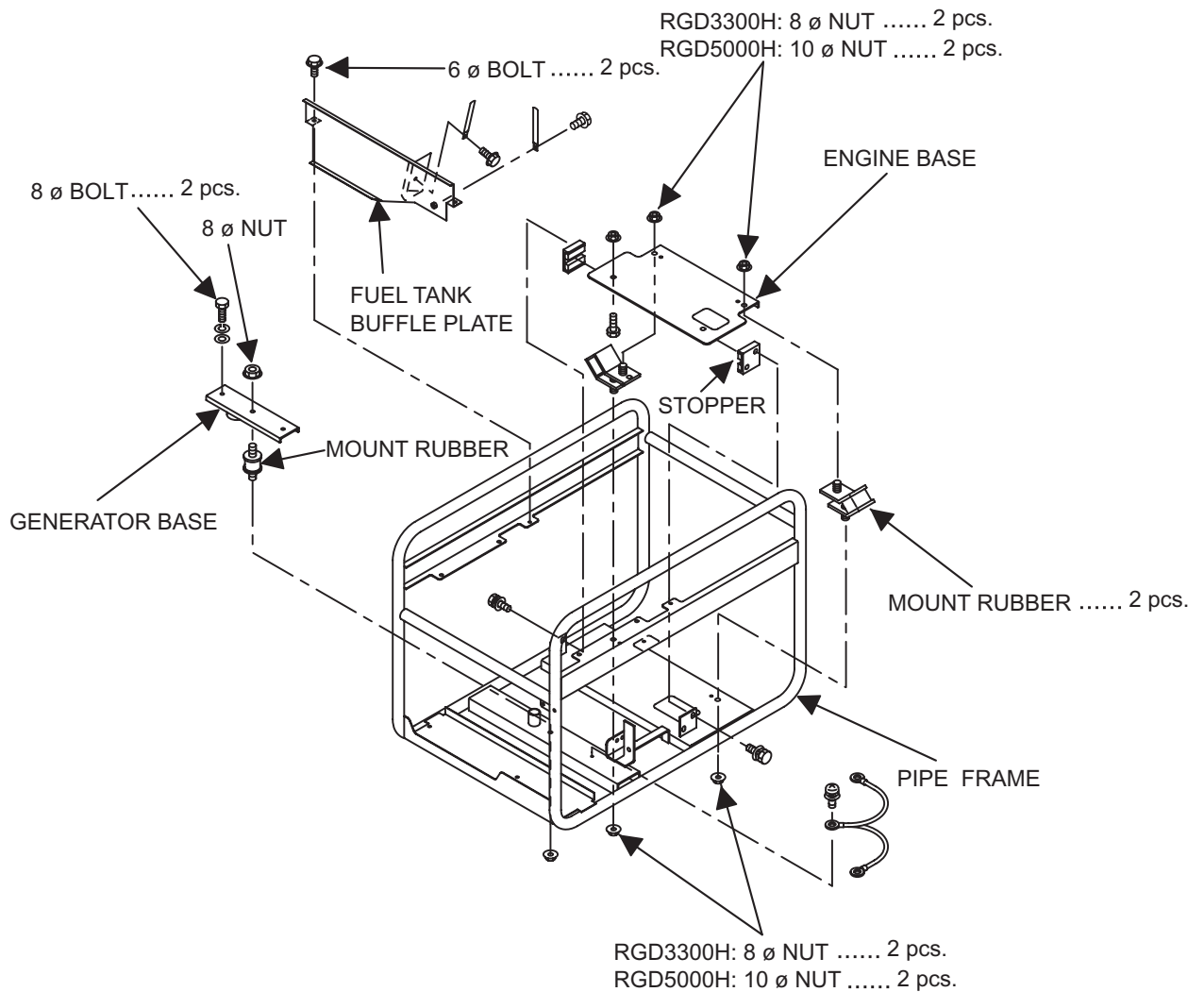

(4) Mount the GENERATOR BASE on the mount rubber attached to the frame at step (3).

8 ϕ flange nut..... 1 pc.

Tightening torque: 11.8 ~ 13.7 N-m (120 ~ 140 kg-cm, 8.68 ~ 10.1 ft-lb)

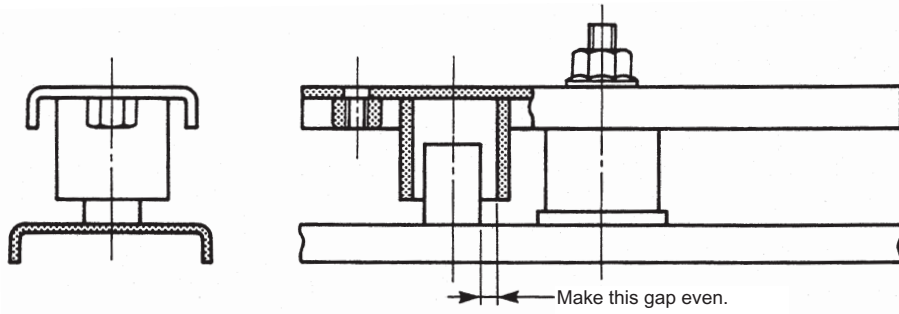

(5) Attach the base plate to the engine.

RGD3300H 8 ϕ

RGD5000H 10 ϕ

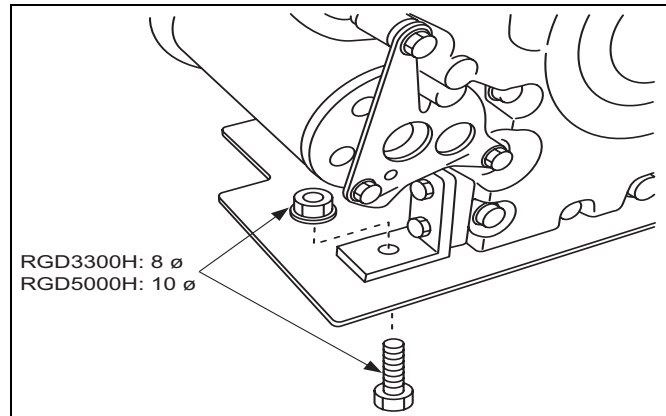

(6) Lift engine and alternator assembly with a chain block and mount it to the frame.
Down the alternator first then the engine into the frame.

Lift the engine by approx. 25 mm so as not to apply weight to the engine mount rubbers.

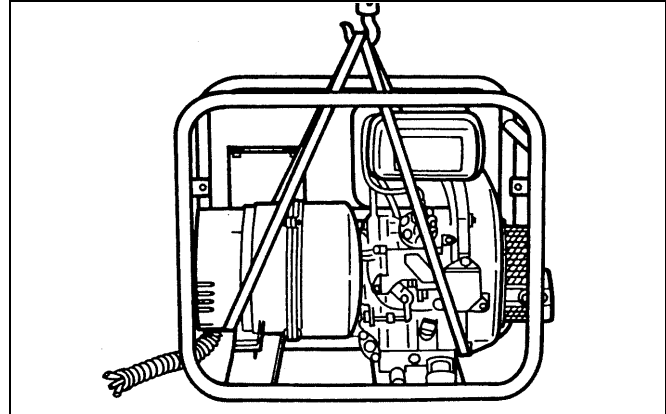

- (7) Fix the legs of rear cover to the generator base.
 Attach the 8 ϕ terminal of the grounding wires and the clamp to the right side leg of the rear cover at the same time.
 Attach the 8 ϕ terminal of the grounding wires, a clamp and the BATTERY CABLE (-) and a clamp to the left side leg of the rear cover at the same time.

NOTE: Two nuts are welded to the bottom side of the GENERATOR BASE.

8 ϕ \times 25 mm bolt & washer assy ... 2 pcs.

Tightening torque: 11.8 ~ 13.7 N-m (120 ~ 140 kg-cm, 8.68 ~ 10.1 ft-lb)

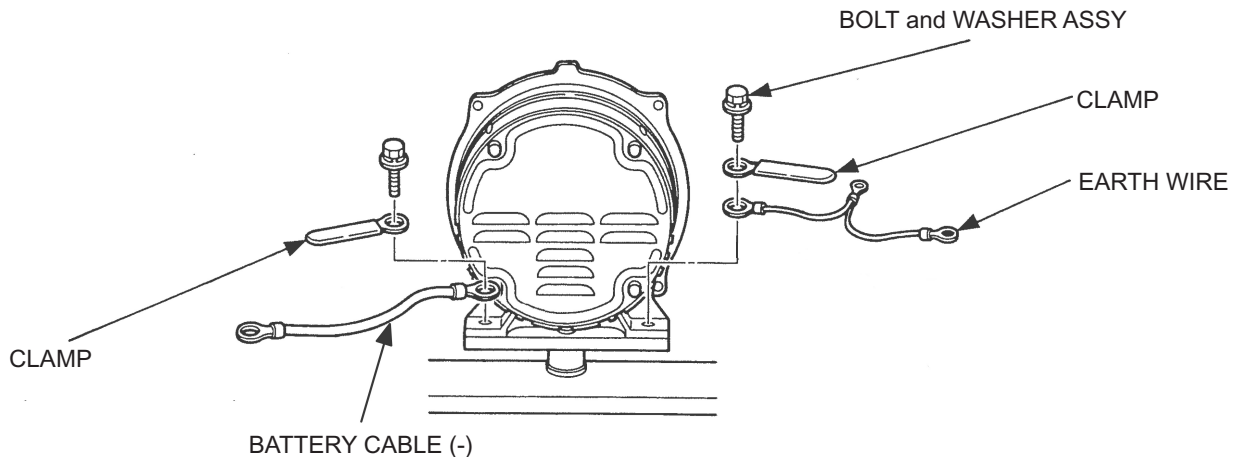

- (8) Fix the engine mount rubbers to the crankcase bracket.

RGD3300H: 8 ϕ flange nut..... 2 pcs.

RGD5000H: 10 ϕ flange nut..... 2 pcs.

Tightening torque: 11.8 ~ 13.7 N-m (120 ~ 140 kg-cm, 8.68 ~ 10.1 ft-lb)

CAUTION: Pay attention to the position of the mount rubbers.

Lift down the engine and alternator assembly and remove the chain block belt.

- (9) Attach the stoppers to the frame.

8 ϕ \times 12 mm bolt 4pcs. (2 places)

Tightening torque: 11.8 ~ 13.7 N-m (120 ~ 140 kg-cm, 8.68 ~ 10.1 ft-lb)

NOTE 1: Set the stoppers so that the engine base is placed in the center of the upper and the lower rubbers.

NOTE 2: If the engine mount rubbers are replaced with new ones, set the stoppers so that the upper rubber touches the engine base. The new mount rubber shall be distorted by approx. 3mm in one month.

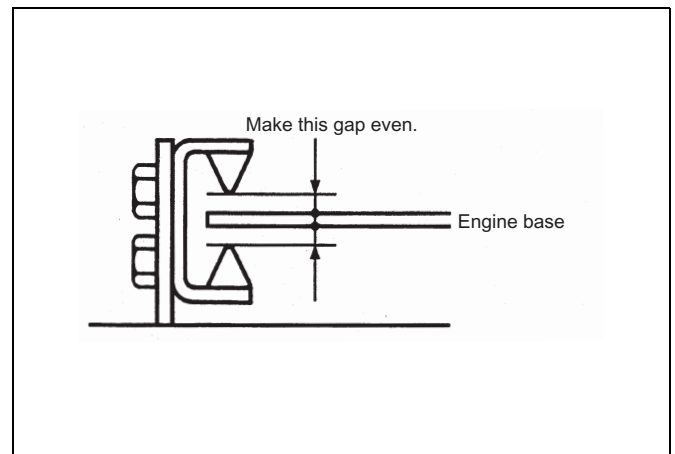

9-4-6 CONTROL BOX

Mount the control box assembly to the frame.

Refer to Section 9-5 for disassembly, checking and reassembly procedures of the control box.

- (1) Attach the 6 \emptyset terminal of the grounding wires to the rear of the control box.

4 \emptyset nut (brass) 1 pc.

Tightening torque: 4.9 ~ 5.9 N-m (50 ~ 60 kg-cm, 3.6 ~ 4.3 ft-lb)

- (2) In the case of generator models equipped with oil sensor, connect the wires to oil pressure switch and solenoid.

- Screw the black/yellow wire to the center of the oil pressure switch.
- Connect the two blue wires to the solenoid and clamp the connectors to the side of speed control unit.

- (3) Connect the wires drawn out from the stator to the wires from the control box.

NOTE 1: Connect the wires of the same color.

NOTE 2: On 240 V model, connect one blue stator lead with a white control box lead.

NOTE 3: Engage the connectors securely.

- (4) Push the wires into the control box and attach the bushing over the wires.

Press the upper end of the bushing into the control box.

- (5) Install the control box to the frame.

6 \emptyset \times 16 mm flange bolt 2 pcs.

6 \emptyset \times 12 mm flange bolt 1 pc.

- 1 Tighten the above three bolts tentatively.
- 2 Tighten the two black bolts which join the side plate to the frame.
- 3 Tighten the above three bolts adjusting the position of the control box.

Tightening torque: 4.9 ~ 5.9 N-m (50 ~ 60 kg-cm, 3.6 ~ 4.3 ft-lb)

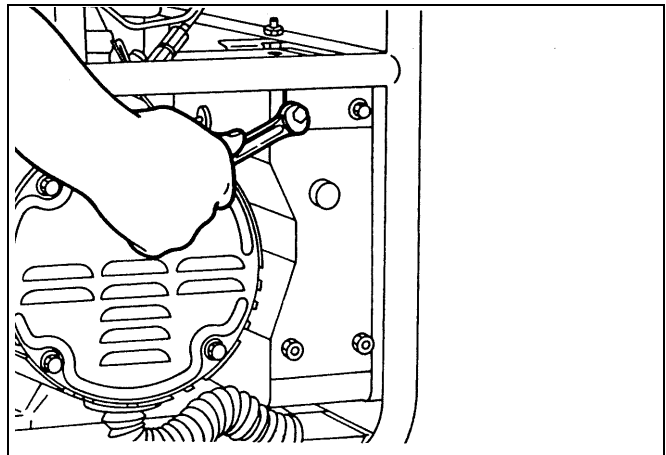
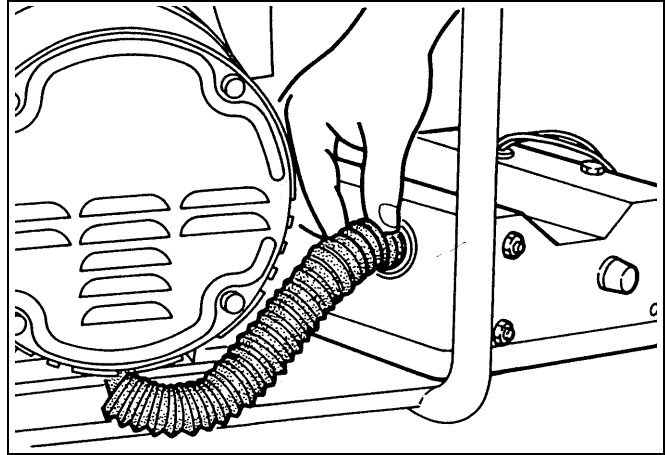

- (6) Connect the coupler for key switch.

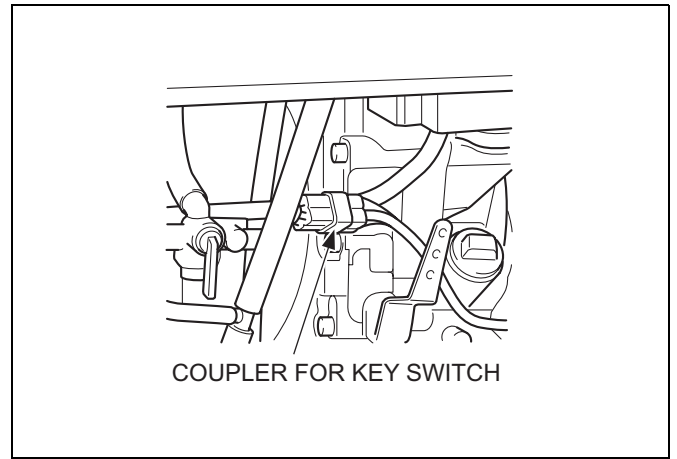

9-4-7 FUEL TANK

- (1) Install the fuel tank with four nuts (8 ϕ).
- (2) Connect the hose clamps (three places).
- (3) Install the fuel cock to the bracket (6 ϕ flange bolt).
- (4) Open the fuel cock.

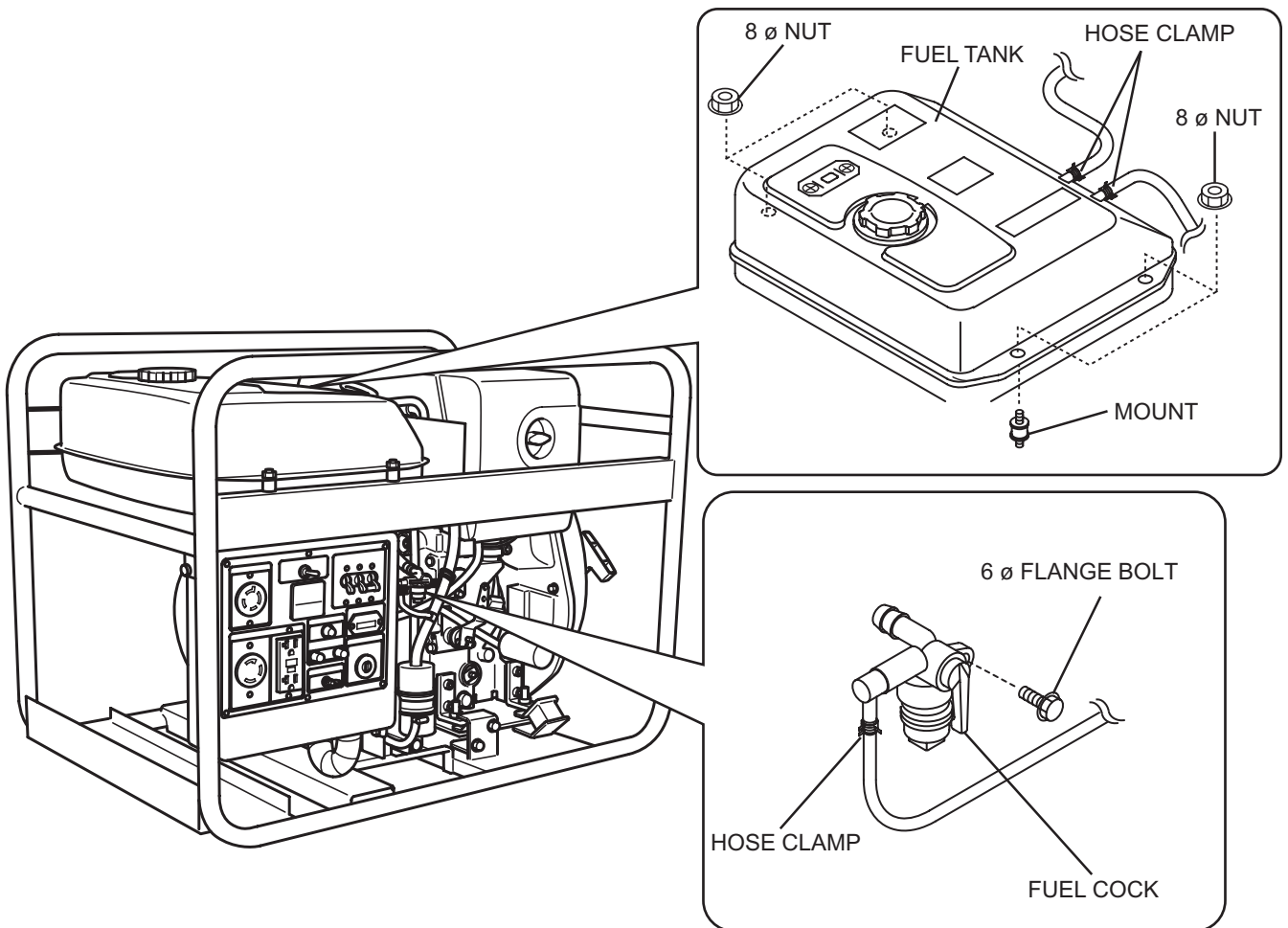

9-4-8 BATTERY FRAME AND BATTERY

- (1) Apply the battery stay to the battery and tighten two nuts with battery bolts installed in position.
6 \emptyset nut..... 2 pcs.
Tightening torque: 4.9 ~ 5.9 N-m (50 ~ 60 kg-cm, 3.6 ~ 4.3 ft-lb)
- (2) Connect battery cables to the battery.
Connect the positive (+) cable first and then the negative (-) cable.

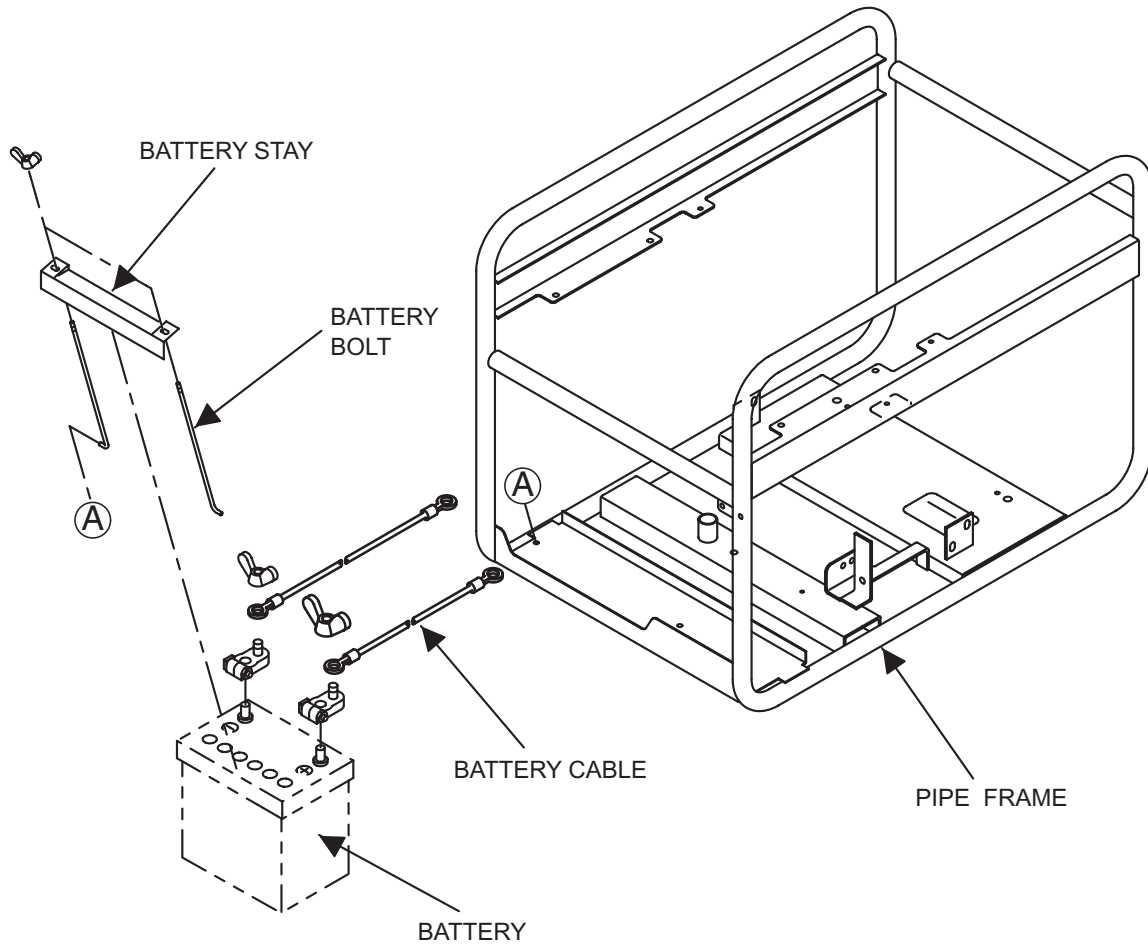

9-5 CONTROL BOX

9-5-1 CHECKING OF THE CONTROL BOX

Dismount the control box from frame.

Remove the control panel and check each components and wiring.

Refer to Section 8. for the detail of checking the components in the control box.

9-5-2 DISASSEMBLY

- (1) Remove the control panel from the control box.

4 \emptyset screw..... 8 pcs.

- (2) Disconnect the connectors on the wires to detach the control panel and box.
- (3) Remove the oil sensor unit, condensers and diode rectifier from the control box.
- (4) After disconnecting individual wires, remove the control panel components.

NOTE: DC fuse, full power switch, pilot lamp and warning lamp have their wires soldered. Unsolder them to remove those parts if necessary.

9-5-3 REASSEMBLY

- (1) Install the receptacles, no-fuse breaker, fuse, terminals, switches, etc. on the control panel and wire them.

NOTE: Circuit diagrams are shown in Section 11. Colored wires are used for easy identification, and are of the correct capacity and size. Use heat-resistant type wires (permissible temperature range 75°C or over).

- (2) Install regulator, oil sensor unit, condensers, and diode rectifier into the control box.
- (3) Connect the wires of control panel components and control box.
Fasten the earth wires to the rear of the control box using a 6 \emptyset nut to the bolt which fixes the condenser bracket to the inside of the control box.
- (4) Attach the control panel to the control box.
4 \emptyset screw..... 8 pcs.
Tightening torque 1.2 ~ 1.5 N-m (12 ~ 15 kg-cm, 0.9 ~ 1.1 ft-lb)

10. TROUBLE SHOOTING

10-1 NO AC OUTPUT

10-1-1 CHECKING STATOR

- Remove control panel and disconnect black, blue, red, and white wires at the connectors.
- Measure the resistance between terminals on stator leads.
Refer to the table below for normal resistance, If stator is faulty, replace with a new one.

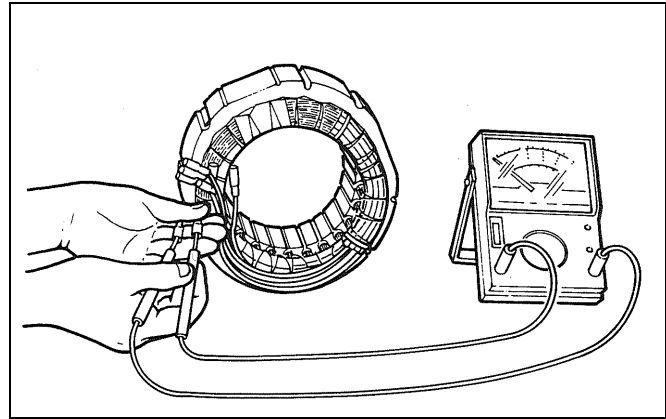

10-1-2 CHECKING CONDENSER

- If an instrument (QC-meter or C-meter) for measuring capacity of condenser is available, check the capacity of condenser.

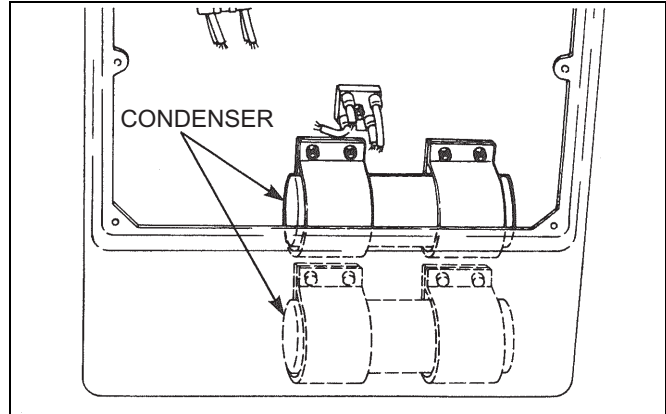

NORMAL CAPACITY OF CONDENSER			
MODEL		RGD3300H	RGD5000H
		60 Hz	60 Hz
CONDENSER	①	20 μ F	30 μ F
	②	20 μ F	30 μ F

- If such an instrument is unavailable, the condenser can be checked by replacing with a new one. If the generator performs good with new condenser, the cause of trouble is defect in original condenser.

10-1-3 CHECKING OF ROTOR

(1) CHECKING FIELD COIL

- Remove rear cover and stator.
- Unsolder the coil ends from the terminals on the rotor.

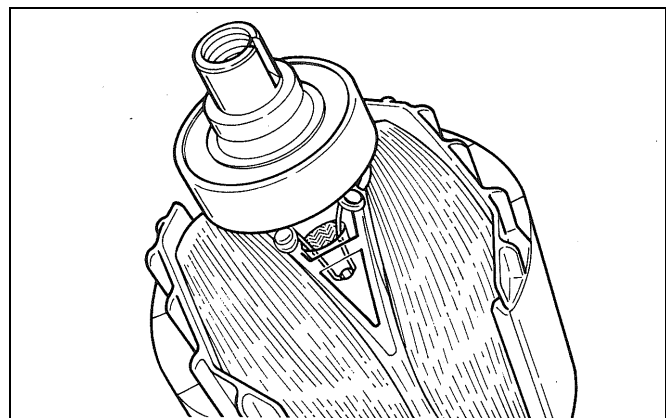

- Measure the resistance of field coil with a circuit tester.

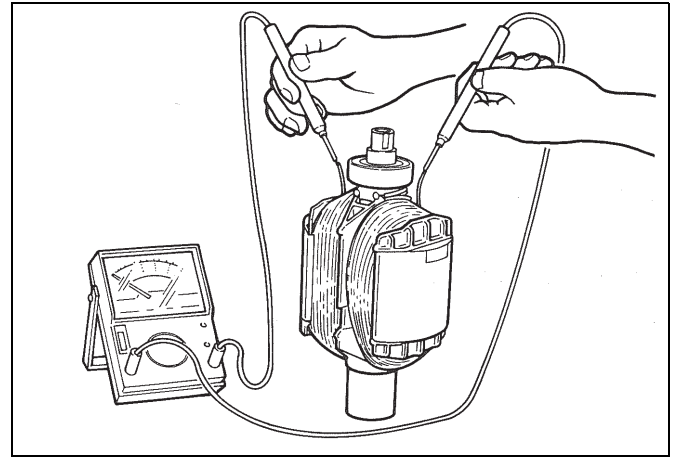

■ NORMAL RESISTANCE

MODEL	RGD3300H	RGD5000H
Resistance	2.1 Ω	1.6 Ω

[Remedy]

If the resistance is not normal, replace rotor with a new one.

(2) CHECKING OF DIODES AND RESISTORS ON THE ROTOR

- Unsolder and take out the diodes and a resistor from rotor.
- Measure the resistance of diodes.

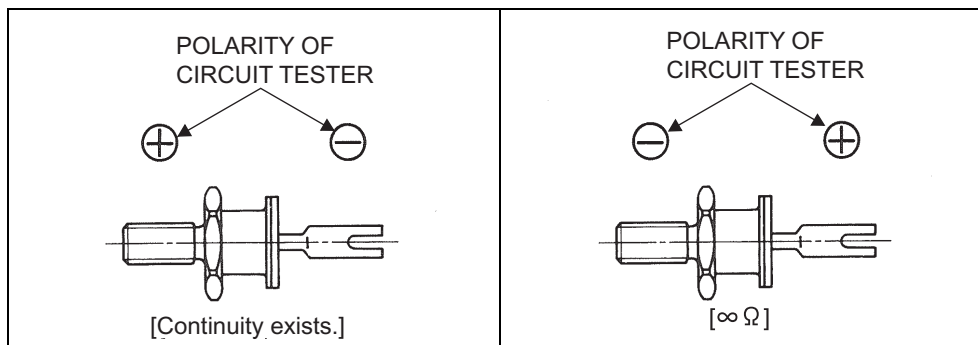

Each rotor has three diodes. Check the resistance of each diode.

- Measure the resistance of surge absorber connected to the diode holder.

NORMAL RESISTANCE: $\infty \Omega$

- Check the magnetic force of permanent magnets molded in the rotor.

[Remedy]

- (1) If the magnetic force of rotor magnets is weak, or if the surge absorber is not good, replace the rotor with a new one.
- (2) If the diode is not good, replace it with a new one.

CAUTION: In case the diode troubles are frequent, check the surge absorber because it might be broken even if its resistance is normal ($\infty \Omega$). In such a case, replace the rotor with a new one.

[Reassembling]

- (1) As shown in the figure, place the white mark on the magnet to the left and solder the diodes so that cathode mark is to be placed at the bottom.
- (2) Solder the coil ends to the terminal.

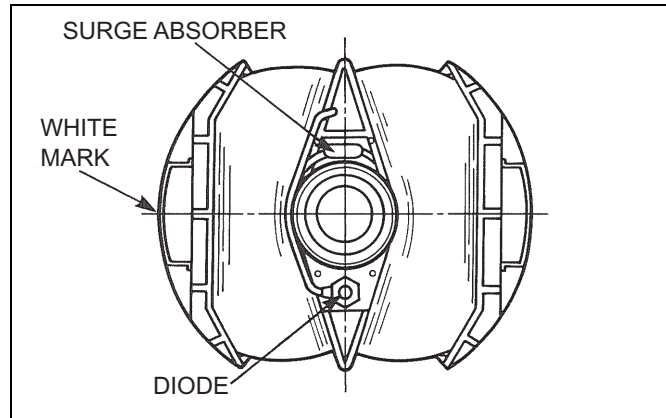

10-2 AC VOLTAGE IS TOO HIGH OR TOO LOW.

10-2-1 CHECKING STATOR

Check stator referring to Step 10-1-1.

10-2-2 CHECKING CONDENSER

Check condenser referring to Step 10-1-2.

10-2-3 CHECKING ROTOR

Check rotor referring to Step 10-1-3.

10-3 AC VOLTAGE IS NORMAL AT NO-LOAD, BUT THE LOAD CANNOT BE APPLIED.

10-3-1 CHECK THE ENGINE SPEED.

If the engine speed is low, adjust it to the rated r.p.m.

* Refer to Step 10-2-1 for engine speed adjustment.

10-3-2 CHECK THE TOTAL WATTAGE OF APPLIANCES CONNECTED TO THE GENERATOR.

Refer to Section 6. "RANGE OF APPLICATIONS" for the wattage of the appliances.

If the generator is over-loaded, reduce the load to the rated output of the generator.

10-3-3 CHECK THE APPLIANCE FOR TROUBLE.

If the appliance is faulty, repair it.

10-3-4 CHECK IF THE ENGINE IS OVERHEATED.

If the cooling air inlet and/or cooling air outlet is clogged with dirt, grass, chaff or other debris, remove it.

10-3-5 CHECK THE INSULATION OF THE GENERATOR.

Stop the engine. Measure the insulation resistance between the live terminal of the receptacle and the ground terminal.

If the insulation resistance is less than 1 M Ω , disassemble the generator and check the insulation resistance of the stator, rotor and the live parts in the control box. (Refer to Section 7-3.)

Any part where the insulation resistance is less than 1 M Ω , the insulation is faulty and may cause electric leakage.

Replace the faulty part.

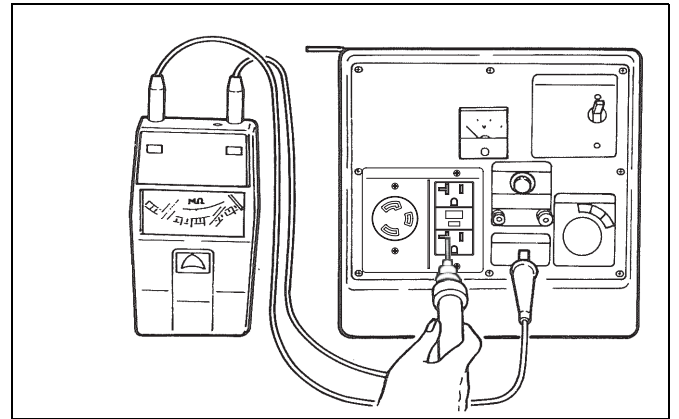

10-4 NO DC OUTPUT

10-4-1 CHECK THE AC OUTPUT.

Check the generator by following Step 10-1-1 through Step 10-1-3.

10-4-2 CHECK THE DC FUSE.

Check the fuse in the fuse holder.

If the fuse is blown, check for the cause of fuse blowing, and then replace with a new one.

FUSE: 10 A

NOTE: If the DC output is used to charge a large capacity battery or an over-discharged battery, an excessive current may flow causing fuse blow.

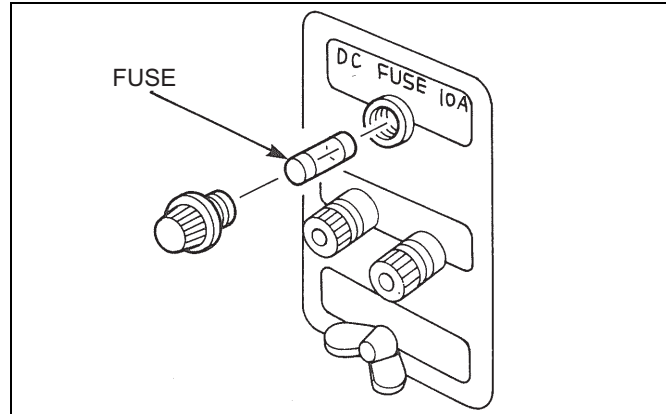

10-4-3 CHECK THE WIRING.

Check all the wires to be connected correctly.

10-4-4 CHECK THE DIODE RECTIFIER.

Remove the control panel and check the diode rectifier with a circuit tester.

Refer to Section 8-6 "DIODE RECTIFIER" for the checking procedure.

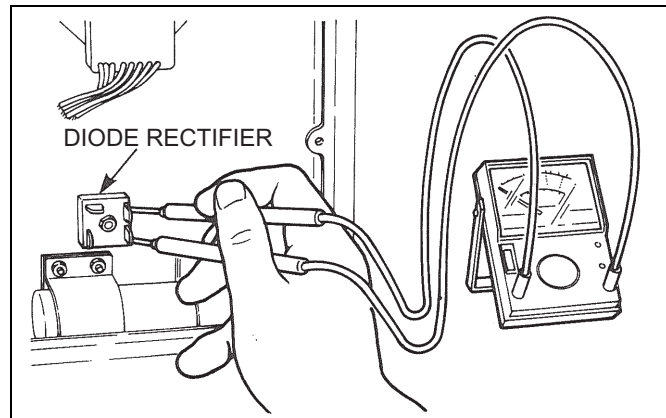

10-4-5 CHECK THE DC COIL

Check the resistance between two brown leads from stator with a circuit tester.

MODEL	SPECIFICATION		RESISTANCE
RGD3300H	60 Hz	120 V 120 V/240 V	0.18
RGD5000H	60 Hz	120 V 120 V/240 V	0.13

If the resistance reading is much larger or smaller than the specified value, the DC coil of the stator is faulty.

Replace stator with a new one.

11. WIRING DIAGRAM

● RGD3300H: 60 Hz-120 V, 240 V TYPE

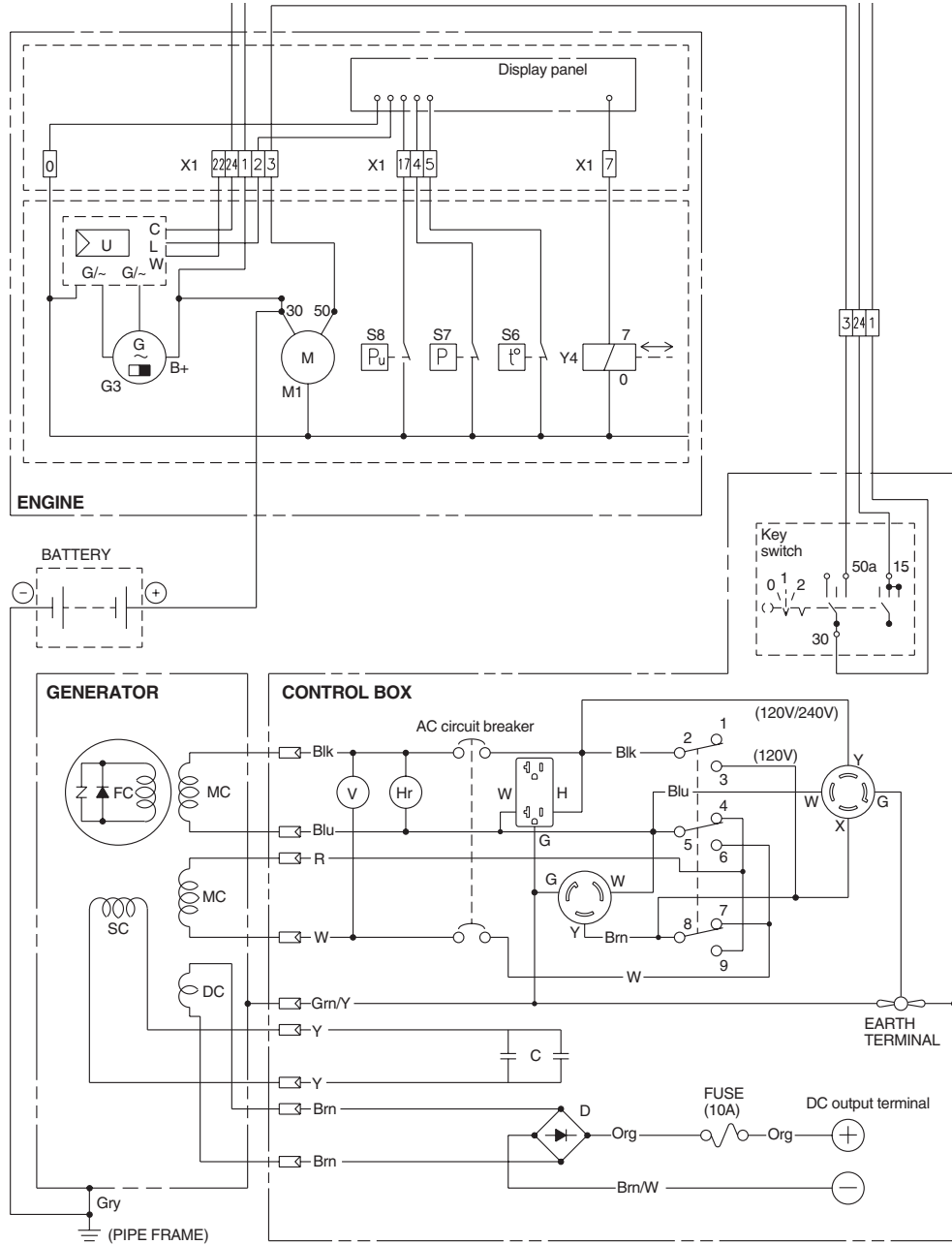

Wiring color cord

Blk : Black	Org : Orange	W : White	Brn/W : Brown/White
R : Red	Brn : Brown	Gry : Gray	
Blu : Blue	Y : Yellow	Grn/Y : Green/Yellow	

MC : AC winding	SC : Auxiliary winding
DC : DC winding	FC : Field winding
C : Condenser	D : Diode stack Assy
V : Voltmeter	

● RGD5000H: 60 Hz-120 V/240 V TYPE

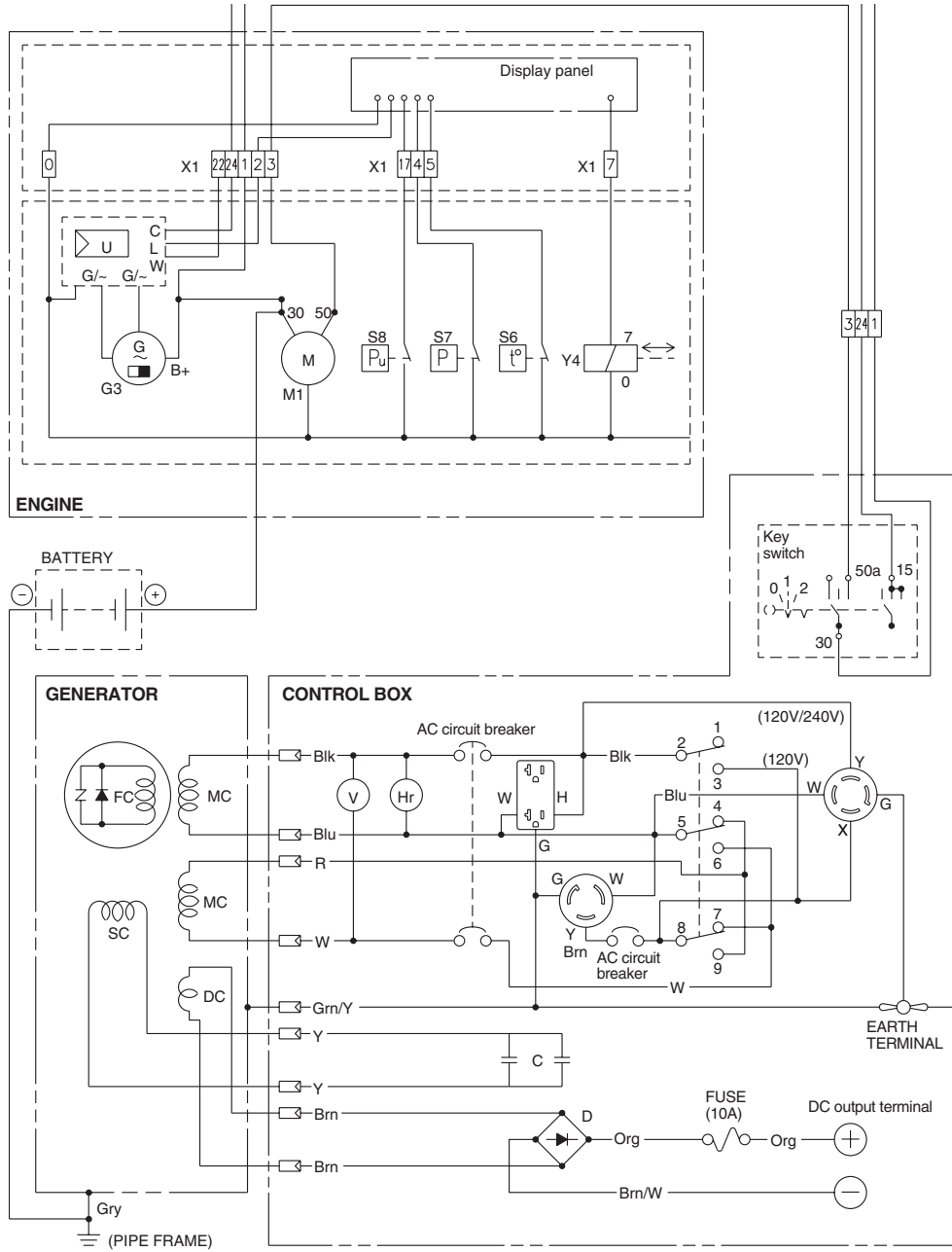

Wiring color cord

Blk : Black	Org : Orange	W : White	Brn/W : Brown/White
R : Red	Brn : Brown	Gry : Gray	
Blu : Blue	Y : Yellow	Grn/Y : Green/Yellow	

MC : AC winding	SC : Auxiliary winding
DC : DC winding	FC : Field winding
C : Condenser	D : Diode stack Assy
V : Voltmeter	

Robin America, Inc.

940 Lively Blvd. • Wood Dale, IL 60191 • Phone: 630-350-8200 • Fax: 630-350-8212
e-mail: sales@robinamerica.com • www.robinamerica.com

© Copyright 2008 Robin America, Inc.

PRINTED IN THE USA