

PARTS MANUAL

Models

**RGD3300H
GENERATOR**

PUB-GP6449
Rev. 10/07

Robin America, Inc.

940 Lively Blvd. • Wood Dale, IL 60191 • Phone: 630-350-8200 • Fax: 630-350-8212
e-mail: sales@robinamerica.com • www.robinamerica.com

© Copyright 2007 Robin America, Inc.

MANUAL LAYOUT

1— SECTION 6 FUEL GROUP

2— FIG. 600

3

4

5

6

7

8

9

10

15

20,27

30

31

40

50

DETAIL A

1—SECTION 6 FUEL GROUP

REF.	PART NO.	DESCRIPTION	QTY.	REMARKS	FROM-TO	FIG.
10	267-60103-01	FUEL TANK CP	1	YD, YS TYPE, BLACK		600
	267-60101-01	FUEL TANK CP	1	YELLOW		600
27	073-20039-00	LABEL, WARNING	1	YD, YS TYPE		600
30	043-04300-15	FUEL TANK CAP CP	1			600
31	267-95201-03	LABEL, EMISSION	1	YD, YS TYPE		600
40	064-13600-10	FUEL FILTER	1			600
50	064-20021-01	FUEL STRAINER AY	1			600
-1	064-20002-20	FILTER	1			600
-2	064-20002-30	GASKET	1			600
-3	064-20019-10	CUP	1			600

1. SECTION NAME Parts are broadly classified according to their functions. Refer to the Group Index (table of contents) for respective section name.
2. FIG. No. The FIG. number indexes the reference and part numbers to the illustration. Figure numbers that vary only in the tens place (i.e.: 700 and 710) are in a group of the same section (i.e.:Electrical Device Group).
3. REF. No . The Reference number identifies the part illustration with the corresponding part number in the part list.
4. SUBASSEMBLY SUBASSEMBLY parts of part assembly are listed below the assembly part. The subassembly part reference number is indicated by the number led by "-" such as "-1", "-2".
5. PART NUMBER It is the number assigned for sales unit. Use the PART No. when making an order.
6. DESCRIPTION It is designation of the part.
7. QTY. Quantity of each part used for each product.
8. REMARKS This gives a distinctive feature and/or a supplementary comment for the type, the specification, and the part concerned. It also shows part number(s) interchangeable for the part.
9. FROM-TO This section shows the CODE No. to indicate the history of progress in which improved parts have been introduced in the product. The FROM-TO CODE No. helps to identify PART No. being employed in the product concerned. See the examples below:
 - The part is used in the product irrespective of CODE No.
 - 2101- The part is used in the products with CODE No. of 2101 and after this number.
 - 2100 The part is used in the products with CODE No. of 2100 and before this number.

GROUP INDEX

Group Name	Page
CRANKCASE GROUP	6
CRANKSHAFT GROUP	8
INTAKE and EXHAUST GROUP	10
GOVERNOR GROUP	18
COOLING and STARTING GROUP	22
FUEL, LUBRICANT GROUP	26
CARBURETOR GROUP	28
ELECTRIC DEVICE GROUP	32
ACCESSORY GROUP	38

INDEX OF DESCRIPTION SYMBOLS			
SYMBOL	DESCRIPTION	SYMBOL	DESCRIPTION
AY	ASSEMBLY	P=	PITCH (in mm)
CP	COMPLETE	P.T.O. (PTO)	POWER TAKE OFF
EX	EXPORT (from Japan)	REF	REFERENCE
FIG	FIGURE	R.H. (RH)	RIGHT HAND SIDE
FR	FRONT	RR	REAR
"	INCH	STD.	STANDARD
INCL.	INCLUDE	SW	SWITCH
~L	LITER	T=	THICKNESS (in mm)
L=	LENGTH (in. mm)	UN	UNIT
L.H. (LH)	LEFT-HAND SIDE	U.S.	UNDER SIZE
MECH	MECHANICAL	~V	VOLTAGE
NO (NON)	NONE	~W	WATT
OPT	OPTIONAL	W/	WITH
O.S.	OVER SIZE	W/O	WITHOUT

SECTION 1 GENERATOR GROUP

FIG. 100

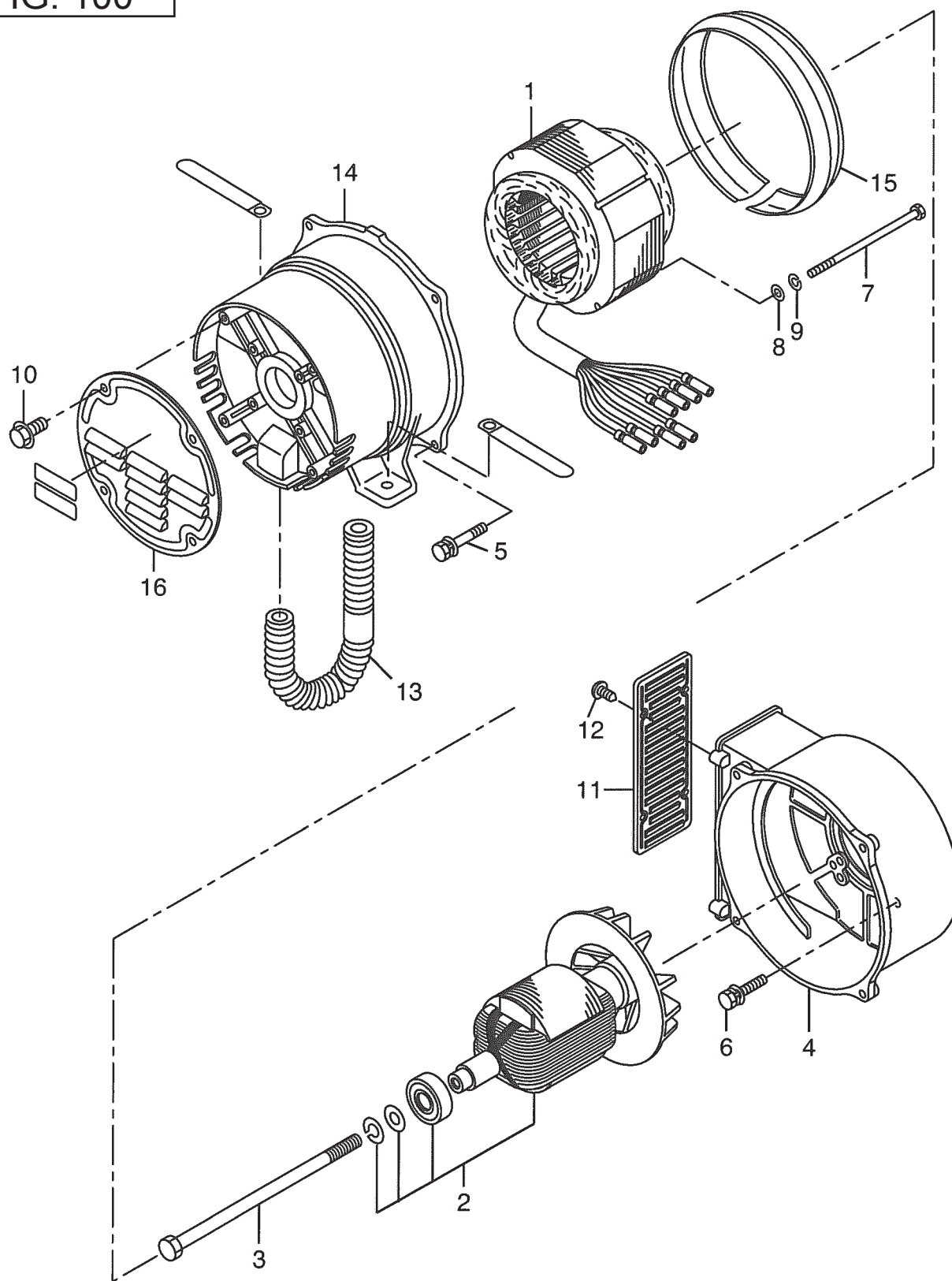

SECTION 2 CONTROL PANEL GROUP

FIG. 200

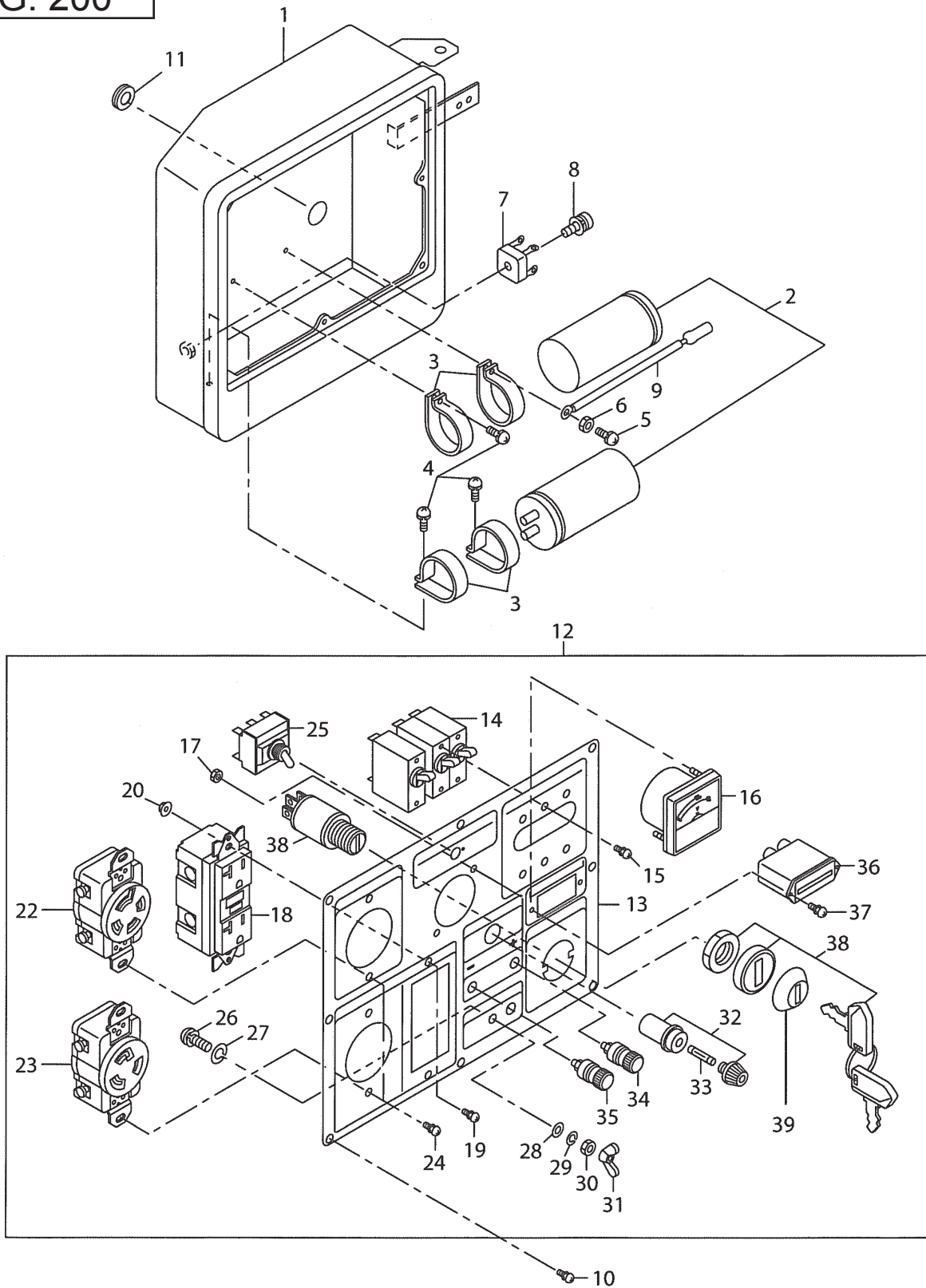

SECTION 3 FRAME GROUP

FIG. 300

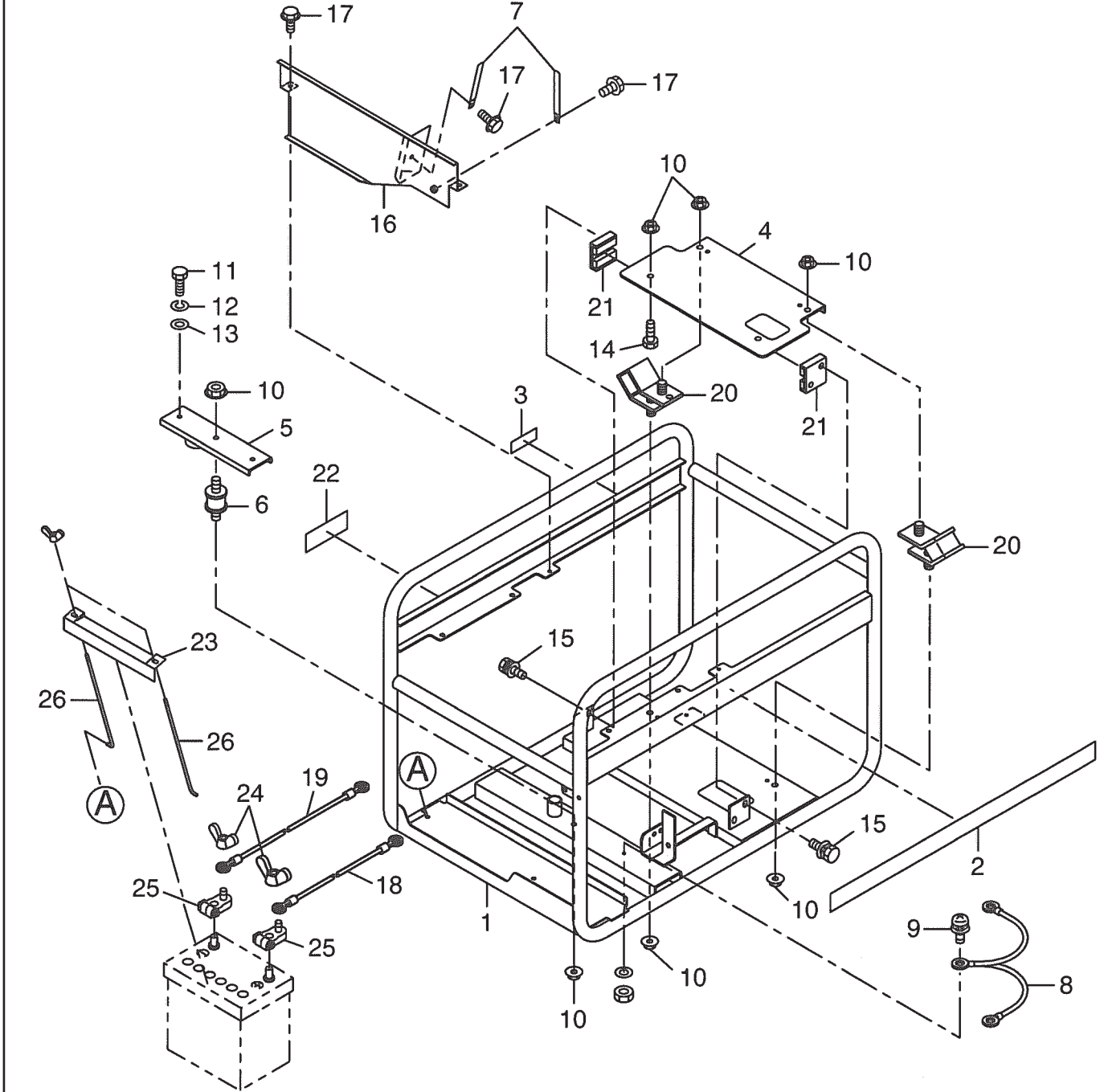

SECTION 4 FUEL TANK GROUP

FIG. 400

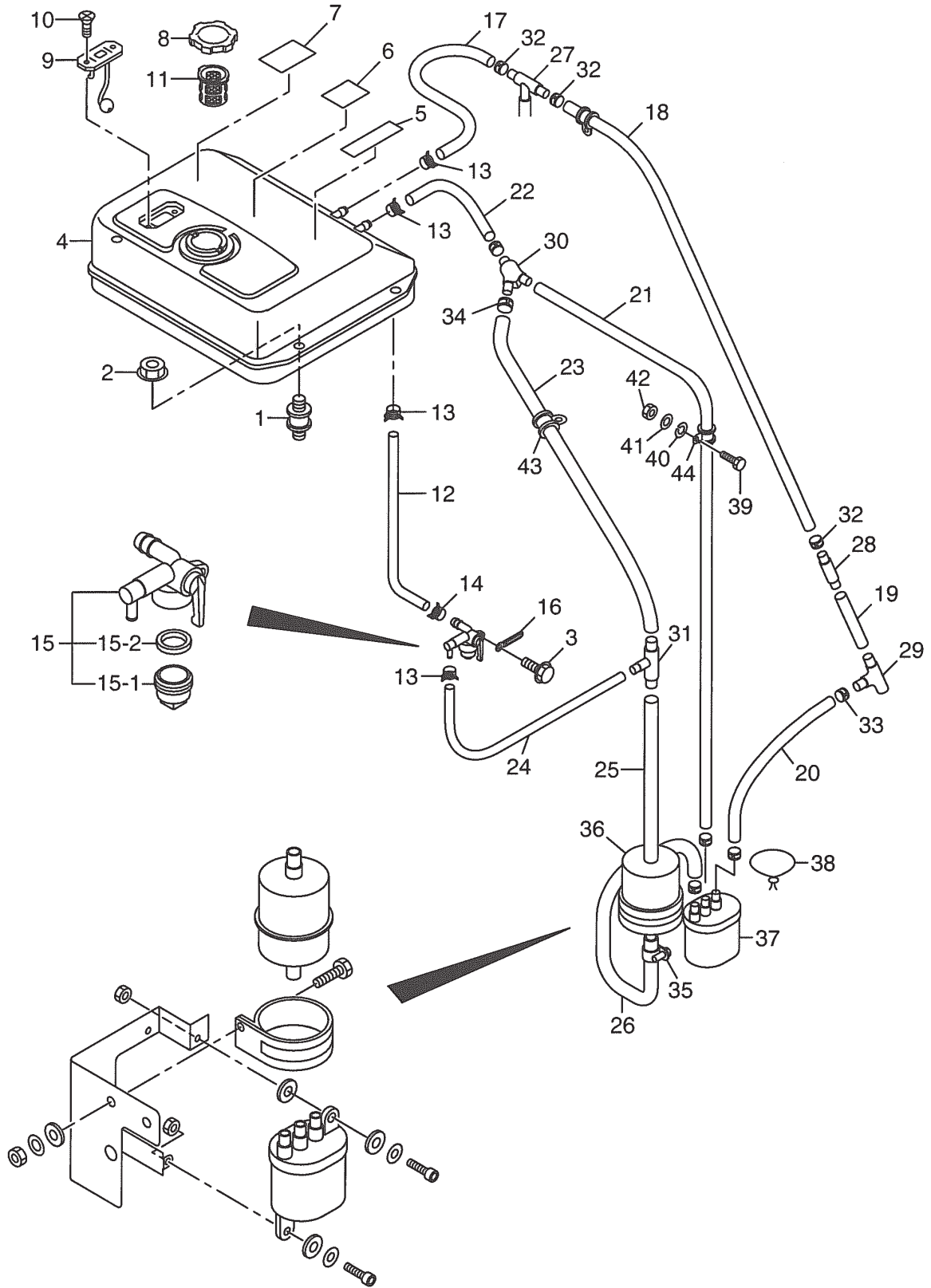

SECTION 4 FUEL TANK GROUP

REF.	PART NO.	DESCRIPTION	QTY.	REMARKS	FROM-TO	FIG.
1	356-57045-08	MOUNT CP	4			400
2	002-37080-00	FLANGE NUT	4			400
3	011-00600-20	FLANGE BOLT	1			400
4	35F-60001-01	FUEL TANK CP	1			400
5	377-92500-03	LABEL, CAUTION	1			400
6	391-94002-03	LABEL, FUEL ONLY	1			400
7	073-20055-80	LABEL, CO GAS	1			400
8	043-04300-15	FUEL TANK CAP CP	1			400
9	064-80006-00	FUEL GAUGE CP	1			400
10	014-50500-40	SCREW, COUNTER HEAD	2			400
11	064-13600-10	FUEL FILTER	1			400
12	35F-60001-01	RUBBER PIPE	1			400
13	377-92500-03	HOSE CLAMP	4			400
14	391-94002-03	HOSE CLAMP	1			400
15	064-20120-00	FUEL COCK AY	1			400
-1	064-20117-00	CUP	1			400
-2	064-20014-30	RUBBER PACKING	1			400
17	DH0-53171-00	RUBBER PIPE	1			400
18	DH0-38071-10	RUBBER PIPE	1			400
19	DH0-52656-00	RUBBER PIPE	1			400
20	DH0-36636-10	RUBBER PIPE	1			400
21	DH0-38068-10	RUBBER PIPE	1			400
22	DH0-53105-00	RUBBER PIPE	1			400
23	DH0-51166-00	RUBBER PIPE	1			400
24	DH0-51888-10	RUBBER PIPE	1			400
25	DH0-53337-00	DH0-38068-10	1			400
26	DH0-51166-00	RUBBER PIPE	1			400
27	DH0-51756-01	T CONNECTOR	1			400
28	DH0-15346-01	CONNECTOR	1			400
29	DH0-17568-00	T CONNECTOR	1			400
30	DH5-05854-00	T CONNECTOR	1			400
31	DH5-04596-00	T CONNECTOR	1			400
32	DH5-05709-00	HOSE CLAMP	6			400
33	DH5-03998-01	HOSE CLAMP	1			400
34	DH5-05112-01	HOSE CLAMP	2			400
35	DH4-00261-00	HOSE CLAMP	1			400
36	DH5-04788-00	FUEL FILTER	1			400
37	DH5-05392-00	FUEL FILTER	1			400
38	DH4-00215-00	WIRE	1			400
39	DH5-01707-00	BOLT	2			400
40	DH5-01445-00	SPRING WASHER	2			400
41	DH5-01709-00	WASHER	2			400
42	DH5-01444-00	NUT	2			400
43	DH5-01584-00	PIPE CLIP	1			400
44	DH5-01735-00	PIPE CLIP	1			400

SECTION 5 CRANKCASE GROUP

FIG. 500

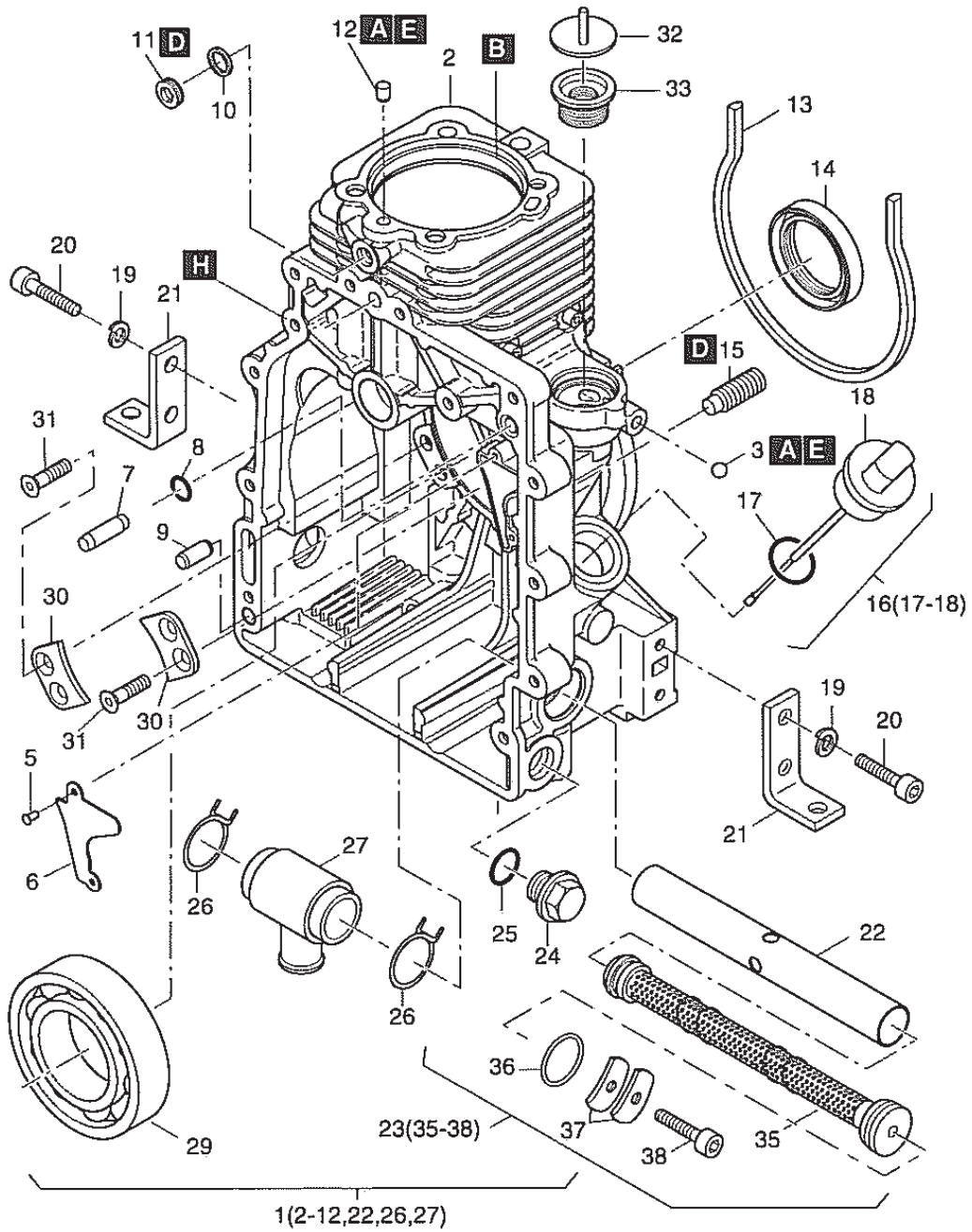

SECTION 6 CRANKSHAFT GROUP

FIG. 600

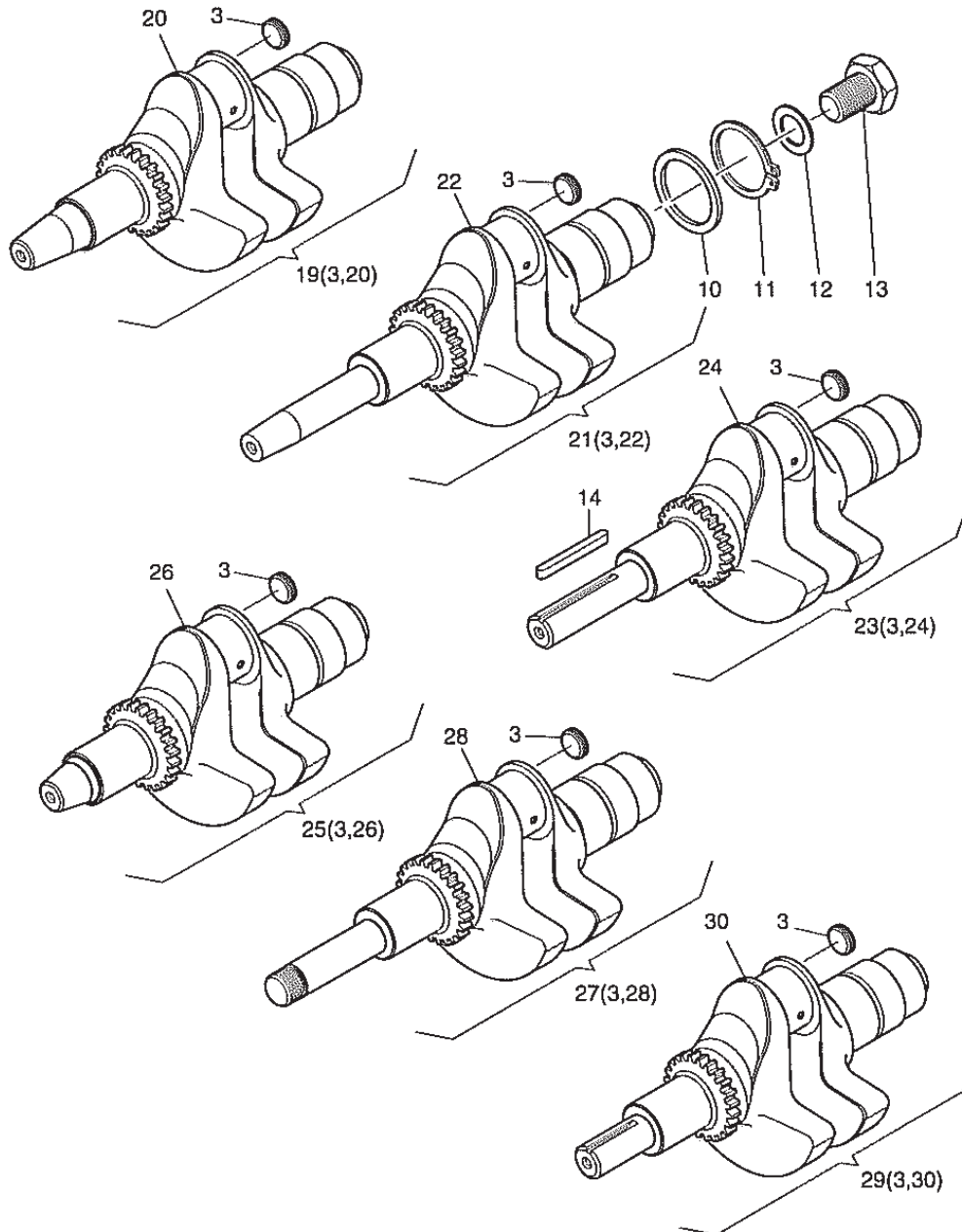

SECTION 8 PISTON GROUP

FIG. 800

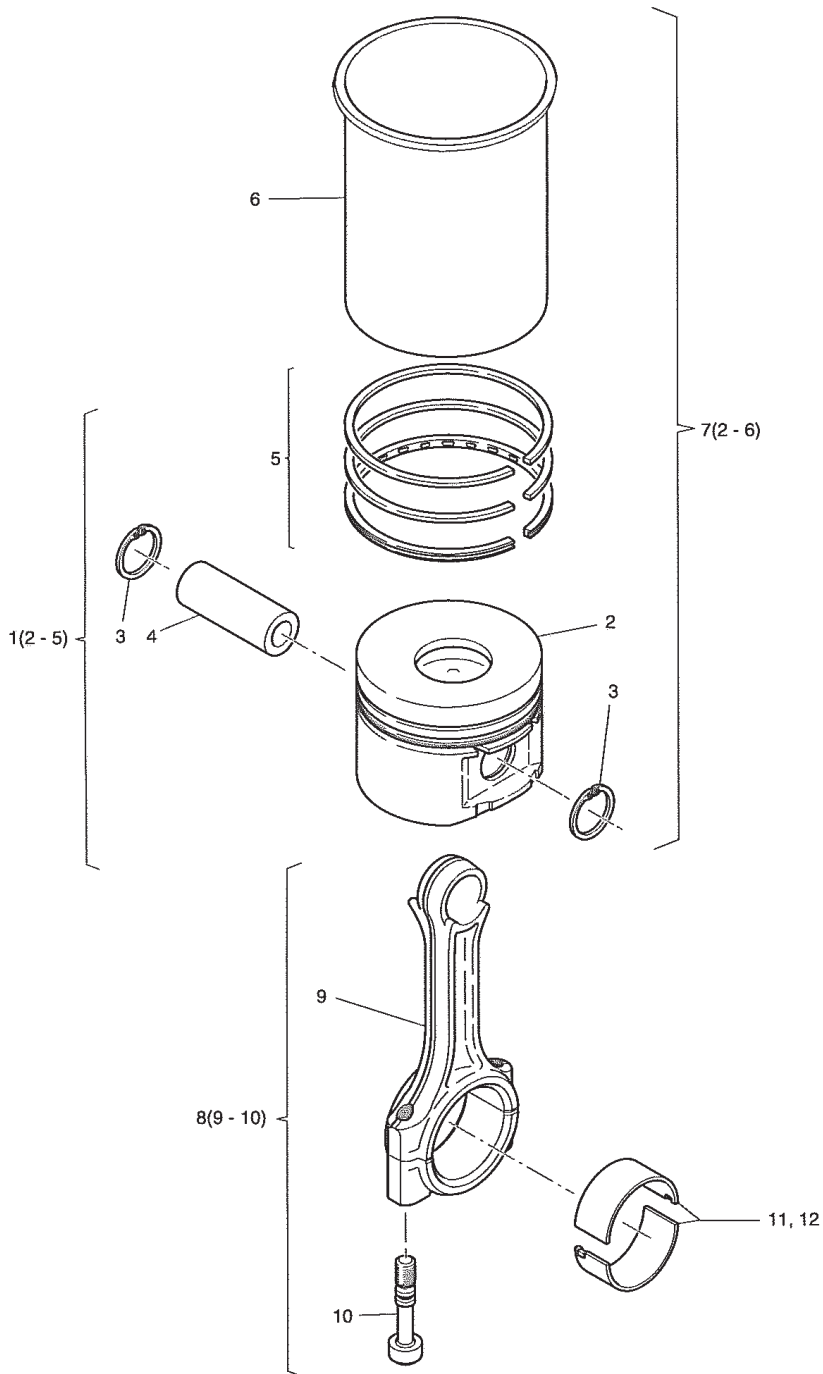

SECTION 9 CYLINDER HEAD GROUP

FIG. 900

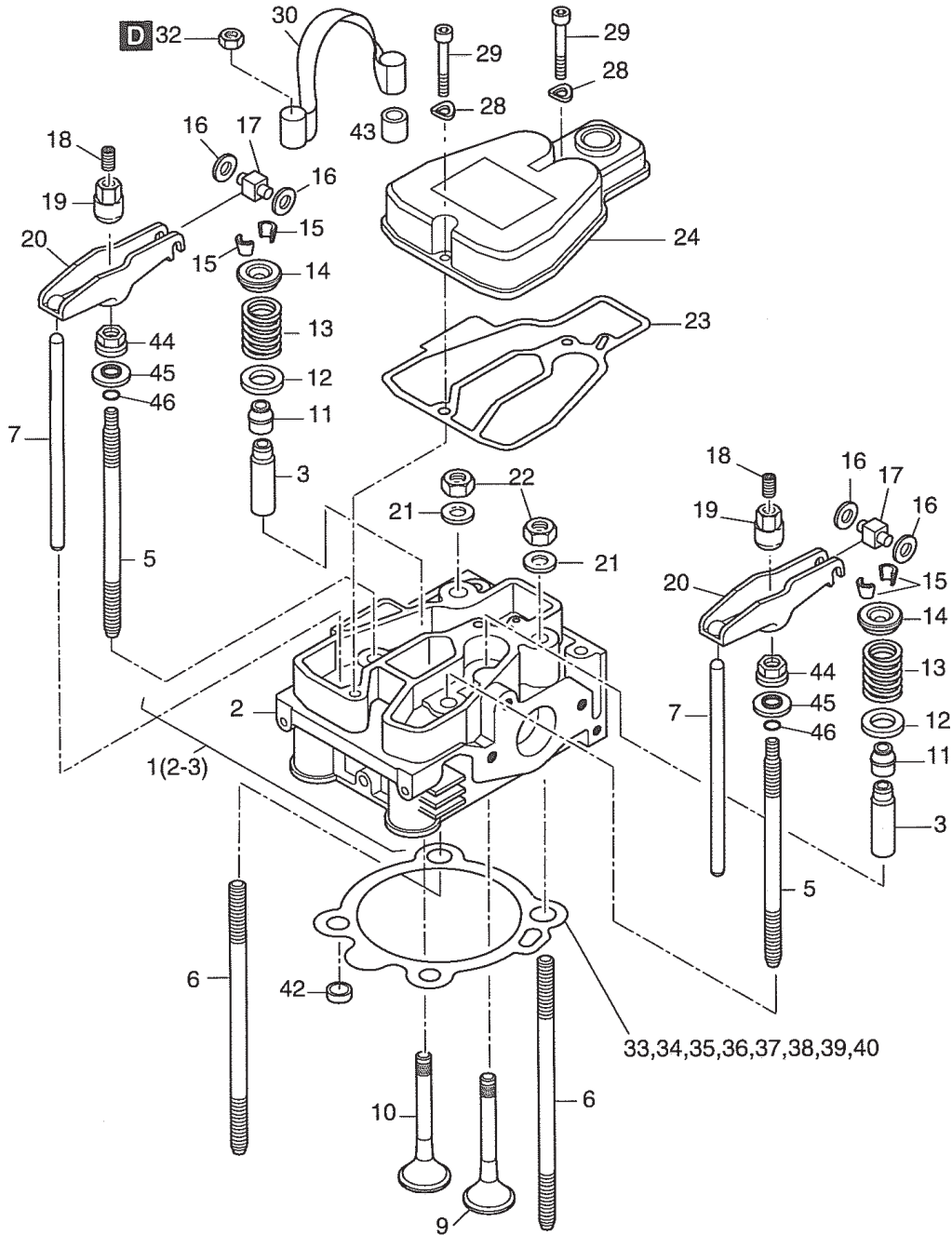

SECTION 10 OIL PUMP, SPEED CONTROL GROUP

FIG.1000

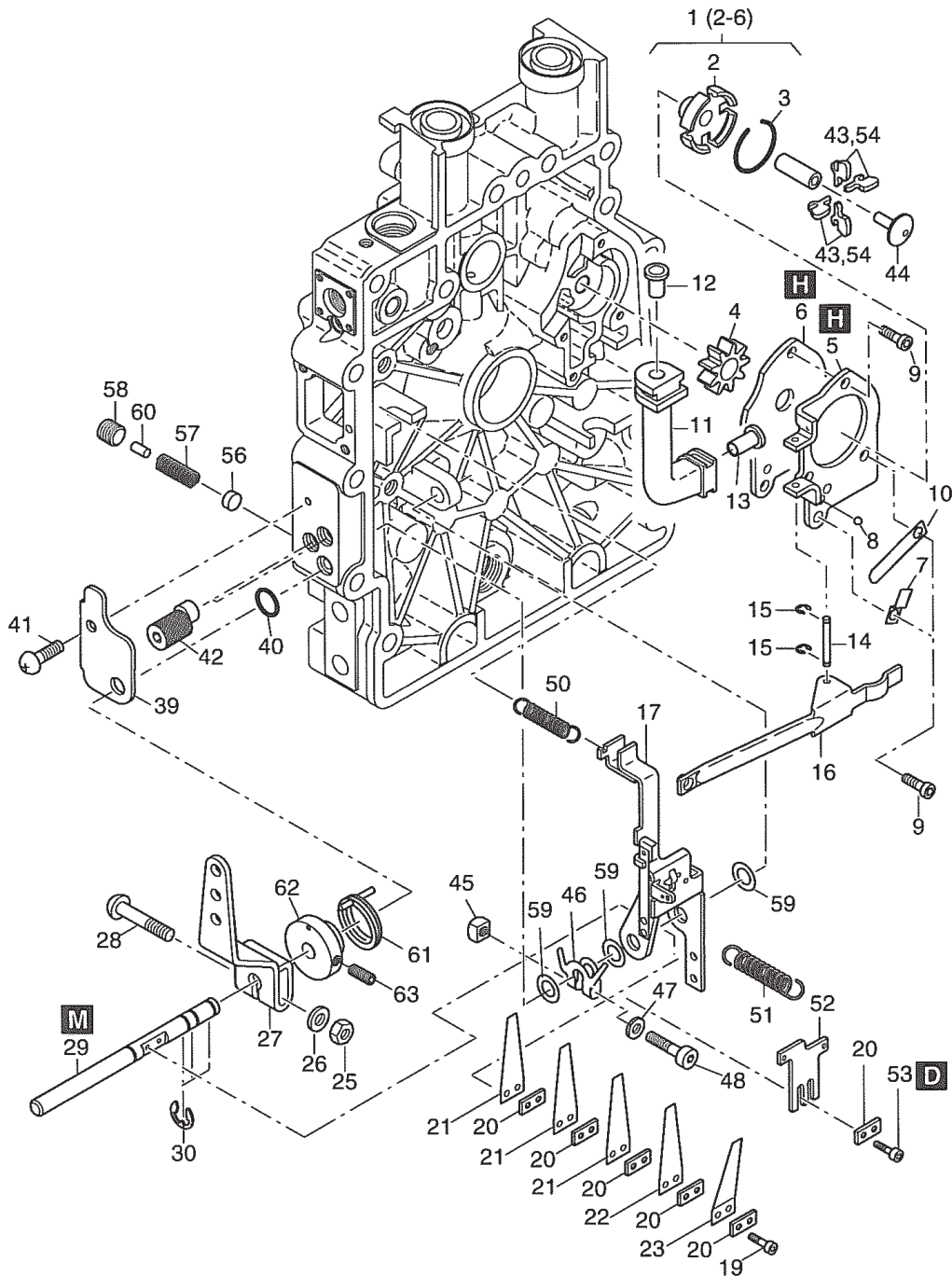

SECTION 10 OIL PUMP, SPEED CONTROL GROUP

REF.	PART NO.	DESCRIPTION	QTY.	REMARKS	FROM-TO	FIG.
1	DH0-15302-20		1			1000
3	DH0-42109-10		1			1000
7	DH0-50971-00	RETAINING STRAP	1			1000
8	DH5-04479-00	BALL 3,5MM	1			1000
9	DH5-04294-00	ALL.SCR. M 5X 12	4			1000
10	DH0-50973-00	FLAT SPRING 0,4	1			1000
11	DH0-41029-00	TUBE OIL SUCTION	1			1000
12	DH5-04474-00	TUBE RIVET A8X0,5X12	1			1000
13	DH5-04475-00	TUBE RIVET 10X12	1			1000
14	DH0-50786-00	SHAFT	1			1000
15	DH5-04348-00	CIRCLIP 1,9	2			1000
16	DH0-50794-01	LEVER	1			1000
17	DH0-15304-01		1			1000
19	DH5-04350-00	ALL.SCR. M 3 X 12	2			1000
20	DH0-50798-00	INTERMED. PLATE	1-5			1000
21	DH0-51316-00	GOVERNOR SPRING 0,2	1-3			1000
22	DH0-50789-00	GOVERNOR SPRING 0,3	1			1000
23	DH0-51486-00	STOP SPRING	1			1000
25	DH5-03465-00	HEXAGON NUT M6	1			1000
26	DH5-01445-00	FLAT WASHER 6,4	1			1000
27	DH0-40956-00		1			1000
28	DH0-39273-01	SCREW M6X32	1			1000
29	DH0-50793-01	SHAFT	1			1000
30	DH5-00927-00	CIRCLIP 7	3			1000
39	DH0-51784-00	PLATE	1			1000
40	DH4-00224-01	O-RING 8 X 2 GRAY	1			1000
41	DH5-04923-00	FILL.HEAD SCR.M5X12	1			1000
42	DH0-51788-10	ECCENTRIC SCREW	2			1000
43	DH0-50796-11	CENTRIFUGAL WEIGHT	0-4			1000
44	DH0-50785-02	GOVERNOR SLEEVE	1			1000
45	DH5-04227-00	SQUARE NUT M 5	1			1000
46	DH0-51785-00	STOP	1			1000
47	DH5-02163-00	WASHER 5,3	1			1000
48	DH5-04922-00	ALL.SCR. M 5X 25	1			1000
50	DH5-05634-00		1			1000
51	DH0-51309-10		1			1000
52	DH0-51308-00	STOP	1			1000
53	DH5-04653-00	ALL.SCR.M 3X 8	2			1000
54	DH0-51602-11	CENTRIFUGAL WEIGHT	0-4			1000
56	DH0-51517-00	PLUG	1			1000
57	DH5-04887-00	PRESSURE SPRING	1			1000
58	DH5-04757-00	GRUB SCREW M10X10	1			1000
59	DH5-04224-00	SHIM 8X14X1	3			1000
60	DH5-00579-00	CYL.PIN 4 M6X 8	1			1000
61	DH0-51791-00	SPRING	1			1000
62	DH0-51790-00	BUSH	1			1000
63	DH5-04006-00	GRUB SCREW M 5X10	1			1000

SECTION 11 TIMING COVER GROUP

FIG. 1100

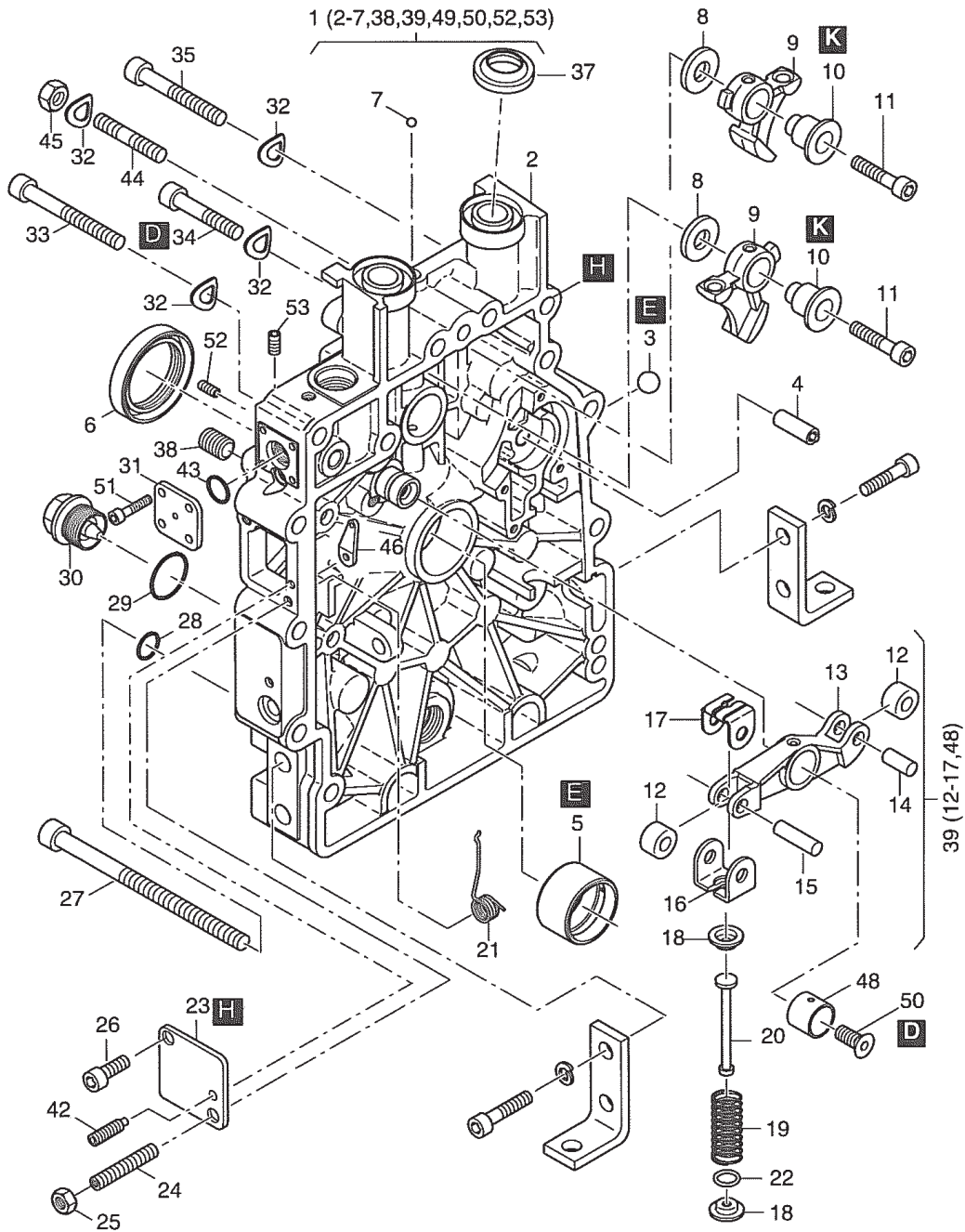

24

SECTION 11 TIMING COVER GROUP

REF.	PART NO.	DESCRIPTION	QTY.	REMARKS	FROM-TO	FIG.
1	DH0-19073-00		1			1100
4	DH0-15339-00		1			1100
5	DH0-41248-00	MAIN BEARING -0.5	1			1100
5	DH0-50531-00	MAIN BEARING	1			1100
6	DH4-00337-01	OIL SEAL 30X47X8	1			1100
8	DH0-37941-00	WASHER	2			1100
9	DH0-50534-00	CAM FOLLOWER	2			1100
10	DH0-37942-01	CAM FOLLOW SPINDLE	2			1100
11	DH5-04579-00		2			1100
18	DH0-40948-02	CUP	2			1100
19	DH0-40957-00	PRESSURE SPRING	1			1100
20	DH0-40947-00	DRAW ROD	1			1100
21	DH0-50952-10	SPRING F.GOVERNOR	1			1100
22	DH0-41339-00	DISC 10,7X19X0,5	1			1100
23	DH0-40952-10	COVER	1			1100
24	DH5-04489-01		1			1100
25	DH5-01444-00	HEXAGON NUT M 6	1			1100
26	DH5-03842-00	ALL.SCR.M 6X 12	1			1100
27	DH5-04630-00	ALL.SCR. M 8X130	2			1100
28	DH5-01629-00	JOINT A 8 X14	2			1100
29	DH5-04698-00	JOINT A22X27	1			1100
30	DH5-03731-00	DRAIN PLG.MAGNT.M22	1			1100
31	DH0-13517-00	COVER	1			1100
32	DH5-00951-00	SPRING WASHER A 8	13			1100
33	DH5-02488-00	ALL.SCREW M 8X60	1			1100
34	DH5-04534-00		2			1100
35	DH5-03929-00	ALL.SCR.M 8 X 50	9			1100
37	DH0-41065-00	SEALG.RING TIM.COV.	2			1100
38	DH5-05306-00	GRUB SCREW M 8X10	5			1100
39	DH0-13196-20		1			1100
42	DH5-02749-01		1			1100
43	DH5-03290-00	O-RING 9,5X2,5	1			1100
44	DH5-00387-00		1			1100
45	DH5-01480-00	HEXAGON NUT M 8	1			1100
46	DH0-51271-00	LEVER	1			1100
50	DH5-04450-00	CTR.SUNK SCR.M6X35	1			1100
51	DH5-03971-00	ALL.SCR.M 4 X 10	4			1100
52	DH5-04006-00	GRUB SCREW M 5X10	2			1100
53	DH5-02624-00	THREADED PIN M 6X10	1			1100

SECTION 12 BLOWER, FLYWHEEL GROUP

FIG. 1200

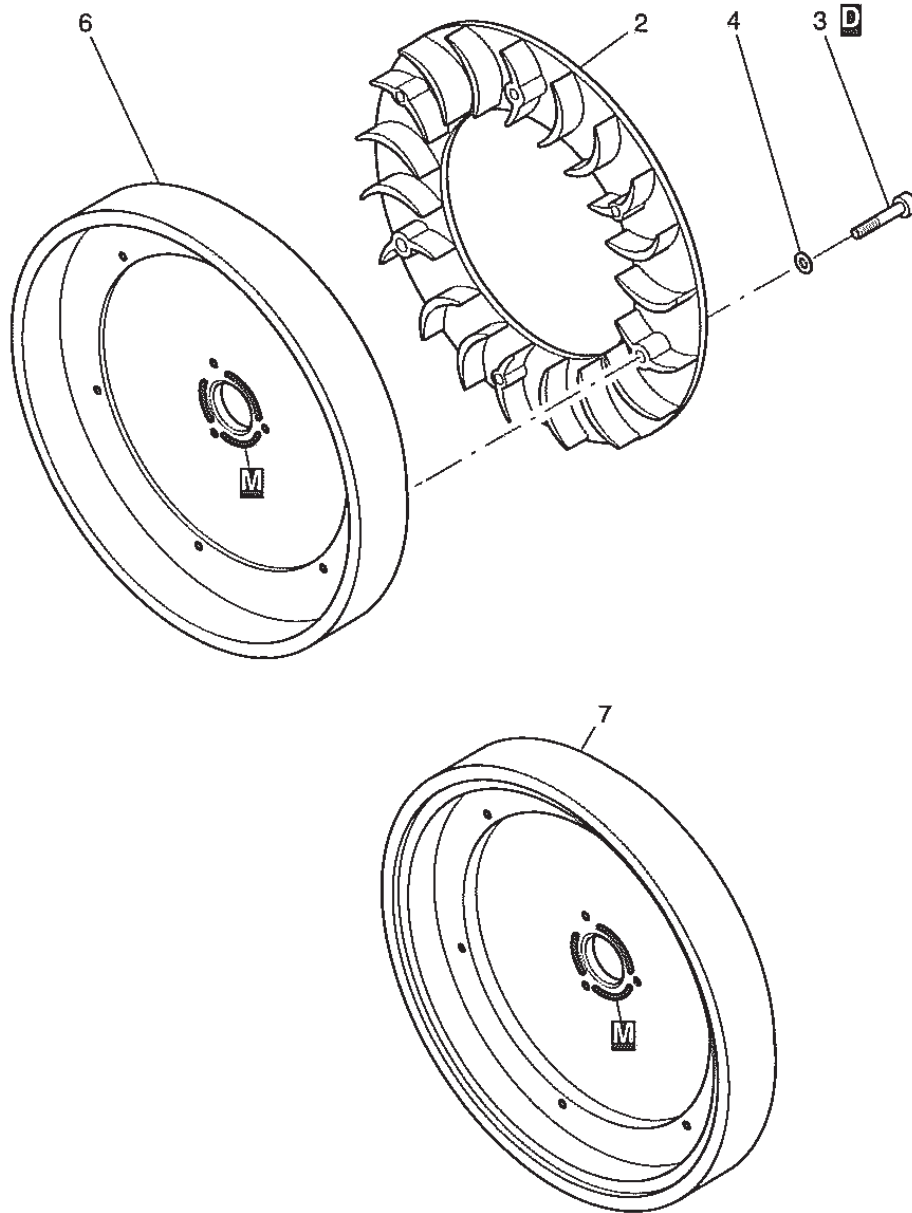

SECTION 13 INJECTION EQUIPMENT GROUP

FIG. 1300

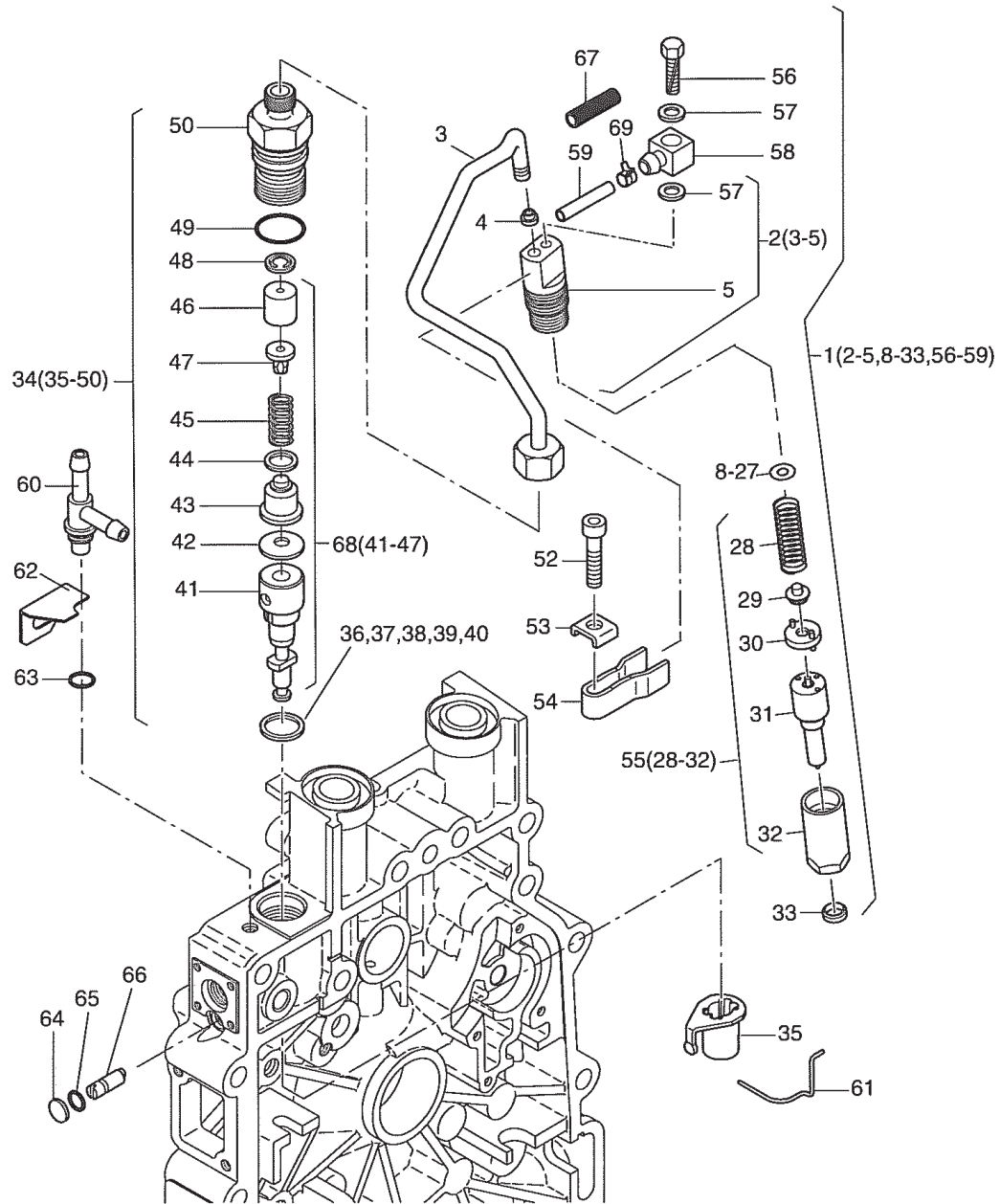

SECTION 13 INJECTION EQUIPMENT GROUP

REF.	PART NO.	DESCRIPTION	QTY.	REMARKS	FROM-TO	FIG.
1	DH0-13896-00	INJECTOR CPL EPA2	1			1300
2	DH0-15828-00	NOZZLE HOLD. PIPE	1			1300
4	DH0-50706-01	SEALING CONE	1			1300
8	DH5-04364-00	SHIM 1,0	1			1300
9	DH5-04365-00	SHIM 1,04	1			1300
10	DH5-04366-00	SHIM 1,10	1			1300
11	DH5-04367-00	SHIM 1,14	1			1300
12	DH5-04368-00	SHIM 1,20	1			1300
13	DH5-04369-00	SHIM 1,24	1			1300
14	DH5-04370-00	SHIM 1,30	1			1300
15	DH5-04371-00	SHIM 1,34	1			1300
16	DH5-04372-00	SHIM 1,40	1			1300
17	DH5-04373-00	SHIM 1,44	1			1300
18	DH5-04374-00	SHIM 1,50	1			1300
19	DH5-04375-00	SHIM 1,54	1			1300
20	DH5-04376-00	SHIM 1,60	1			1300
21	DH5-04377-00	SHIM 1,64	1			1300
22	DH5-04378-00	SHIM 1,70	1			1300
23	DH5-04379-00	SHIM 1,74	1			1300
24	DH5-04380-00	SHIM 1,80	1			1300
25	DH5-04381-00	SHIM 1,84	1			1300
26	DH5-04382-00	SHIM 1,90	1			1300
27	DH5-04383-00	SHIM 1,94	1			1300
31	DH5-05667-00	NOZZLE EPA2	1			1300
33	DH0-50705-00	JOINT WASH.F.INJECT	1			1300
34	DH0-15829-10	INJECTION PUMP EPA2	1			1300
35	DH0-13308-01	CONTROL SLEEVE	1			1300
38	DH0-40965-00	SHIM 14X18X0,4	1			1300
39	DH0-40966-00	SHIM 14X18X0,5	1			1300
40	DH0-40967-00	SHIM 14X18X0,6	1			1300
42	DH0-41652-00	CON.SPR.WASHER 8	1			1300
44	DH5-04769-00	JOINT WASHER	1			1300
48	DH0-51808-00	VALVE PLATE	1			1300
49	DH5-04892-00	O-RING 17 X 2	1			1300
50	DH0-51811-00	DELIV.VALVE HOLDER	1			1300
52	DH5-03239-00	ALL.SCR.M 6X 30	1			1300
53	DH0-50893-00	RETAINING YOKE	1			1300
54	DH0-50567-00	FORK F. INJECTOR	1			1300
56	DH5-04645-00	HEX SCREW AM 4 X 16	1			1300
57	DH5-01108-00	JOINT A 4X8	2			1300
58	DH0-51290-00	CONNECTING NIPPLE	1			1300
59	DH0-52150-00	HOSE 2,5X195	1			1300
60	DH0-17568-00	NIPPLE	1			1300
61	DH0-41618-00	HOLDING SPRING	1			1300
62	DH0-51831-00	SUPPORT	1			1300
63	DH5-01543-00	O-RING 7,5X10,5X1,5	1			1300

SECTION 13 INJECTION EQUIPMENT GROUP

FIG. 1300

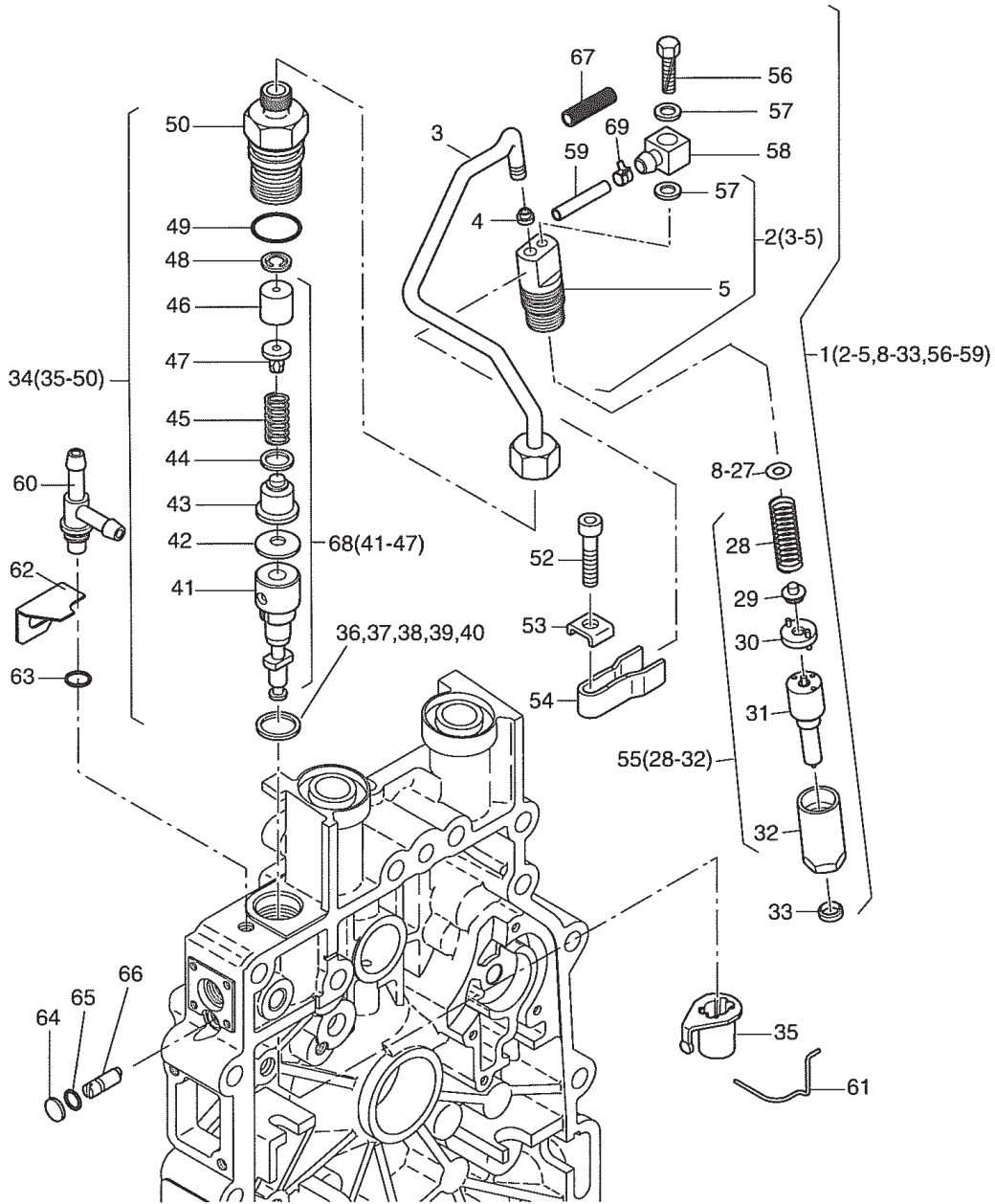

SECTION 14 RECOIL STARTER GROUP

FIG. 1400

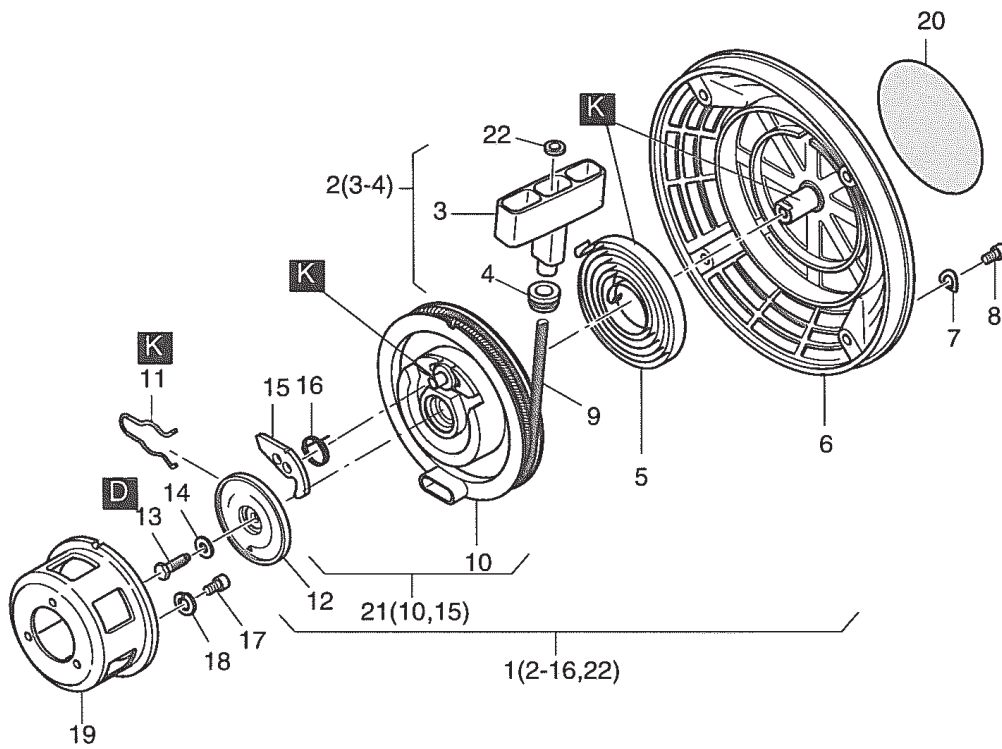

SECTION 15 AIR DUCTING GROUP

FIG. 1500

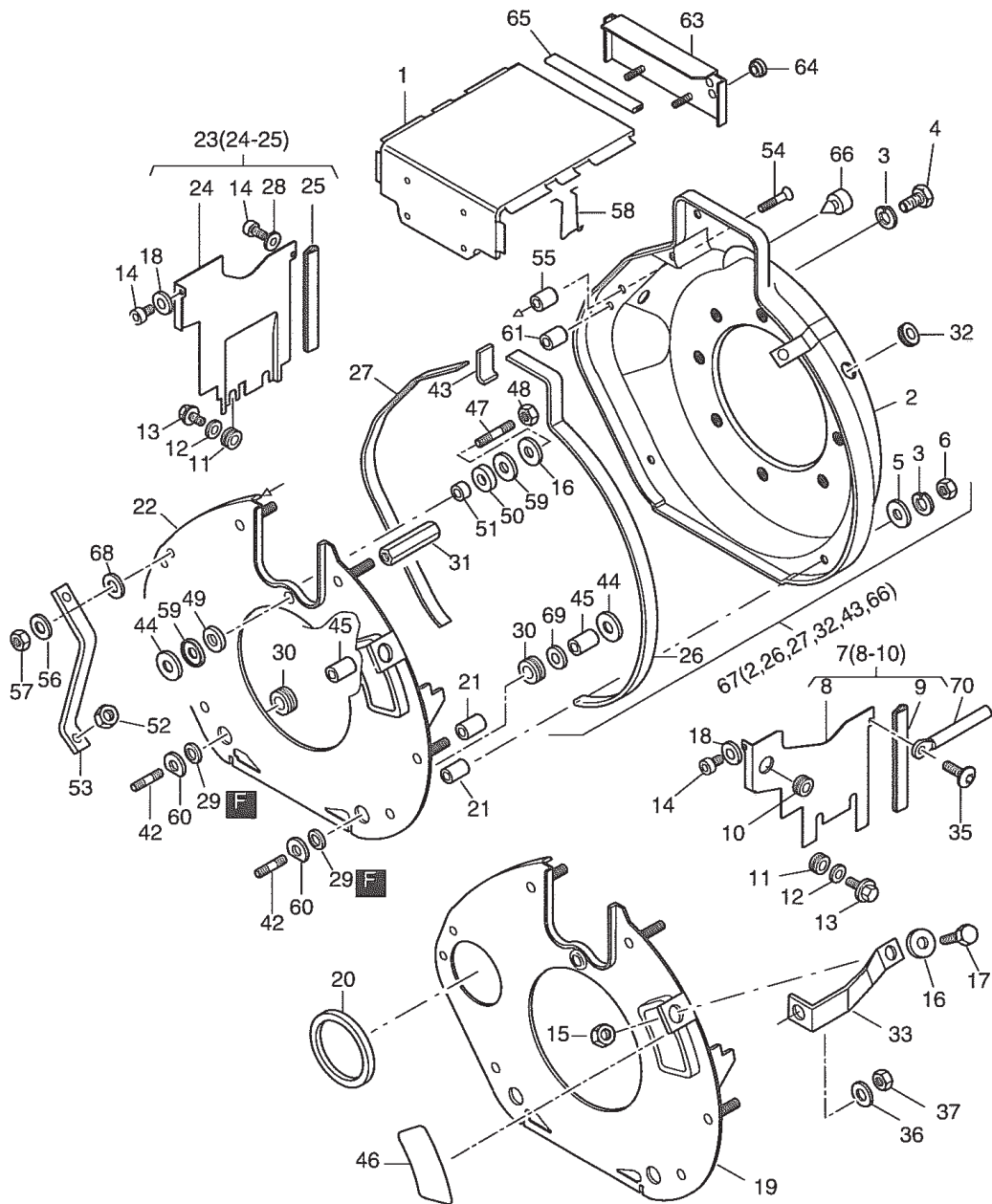

SECTION 15 AIR DUCTING GROUP

REF.	PART NO.	DESCRIPTION	QTY.	REMARKS	FROM-TO	FIG.
1	DH0-18528-00		1			1500
3	DH5-01709-00	SPRING WASHER 6	7			1500
4	DH5-01463-00	HEX SCREW M 6X 18	1			1500
5	DH5-01200-00	DISC A 6,4	2			1500
6	DH5-01444-00	HEXAGON NUT M 6	6			1500
7	DH0-13263-00	COOLING AIR DUCTING	1			1500
9	DH0-51289-00	SEALING STRIP 80MM	1			1500
10	DH5-03348-00	RUBBER SLEEVE	1			1500
11	DH5-01638-01	RUBBER SLEEVE	3			1500
12	DH5-04416-00	WASHER 4,3	3			1500
13	DH5-04454-01	FILL.HEAD SCR.M4X10	3			1500
14	DH5-05281-00	ALL.SCR. M 6X 16	3			1500
15	DH5-01444-00	HEXAGON NUT M 6	1			1500
16	DH5-01143-00	DISC 6,4	2			1500
17	DH5-01771-00	HEX SCREW M 6X 16	1			1500
18	DH5-01445-00	FLAT WASHER 6,4	2			1500
19	DH0-13268-10	PARTING SHEET	1			1500
20	DH0-40995-00	SEALING RING	1			1500
21	DH0-51975-00	BUSH 6,5X12X20	4			1500
22	DH0-13267-10	PARTING SHEET	1			1500
23	DH0-13262-00	COOLING AIR DUCT.	1			1500
25	DH0-41115-00	SEALING STRIP 119MM	1			1500
26	DH0-51081-00	SEALING STRIP495MM	1			1500
27	DH0-41246-00	SEALING STRIP 388MM	1			1500
28	DH0-40606-00	WASHER 6,4X16X1,5	1			1500
29	DH0-35755-00	RUBBER SEAL RING	2			1500
30	DH0-13783-00	SPACER BUSH	2			1500
31	DH0-51981-00	SPACER	1			1500
32	DH5-04533-00	RUBBER SLEEVE	1			1500
33	DH0-15996-10	SUPPORT	1			1500
35	DH5-04950-00	SCREW M6X12	1			1500
36	DH5-00951-00	SPRING WASHER A 8	1			1500
37	DH5-03447-00	HEXAGON NUT M 8	1			1500
42	DH5-04581-00	STUD M 6 X45	2			1500
43	DH0-51982-00	SEALING STRIP 48	1			1500
44	DH0-40420-00	WASHER 6,5X22,5X1	3			1500
45	DH0-40984-00	SPAC.TUBE 7X12X16,3	2			1500
46	DH0-42150-00		1			1500
47	DH5-04644-01	STUD M 6FO X35	1			1500
48	DH5-03283-00	HEXAGON NUT VM6	1			1500
49	DH0-51338-00	RUBBER SEAL RING	1			1500
50	DH0-51339-00	RUBBER SEAL RING	1			1500
51	DH0-51327-00	BUSH 6,5X17X11,5	1			1500
52	DH5-01480-00	HEXAGON NUT M 8	1			1500
53	DH0-51330-01	SUPPORT F.FUEL TANK	1			1500
54	DH5-04450-00	CTR.SUNK SCR.M6X35	1			1500

SECTION 15 AIR DUCTING GROUP

FIG. 1500

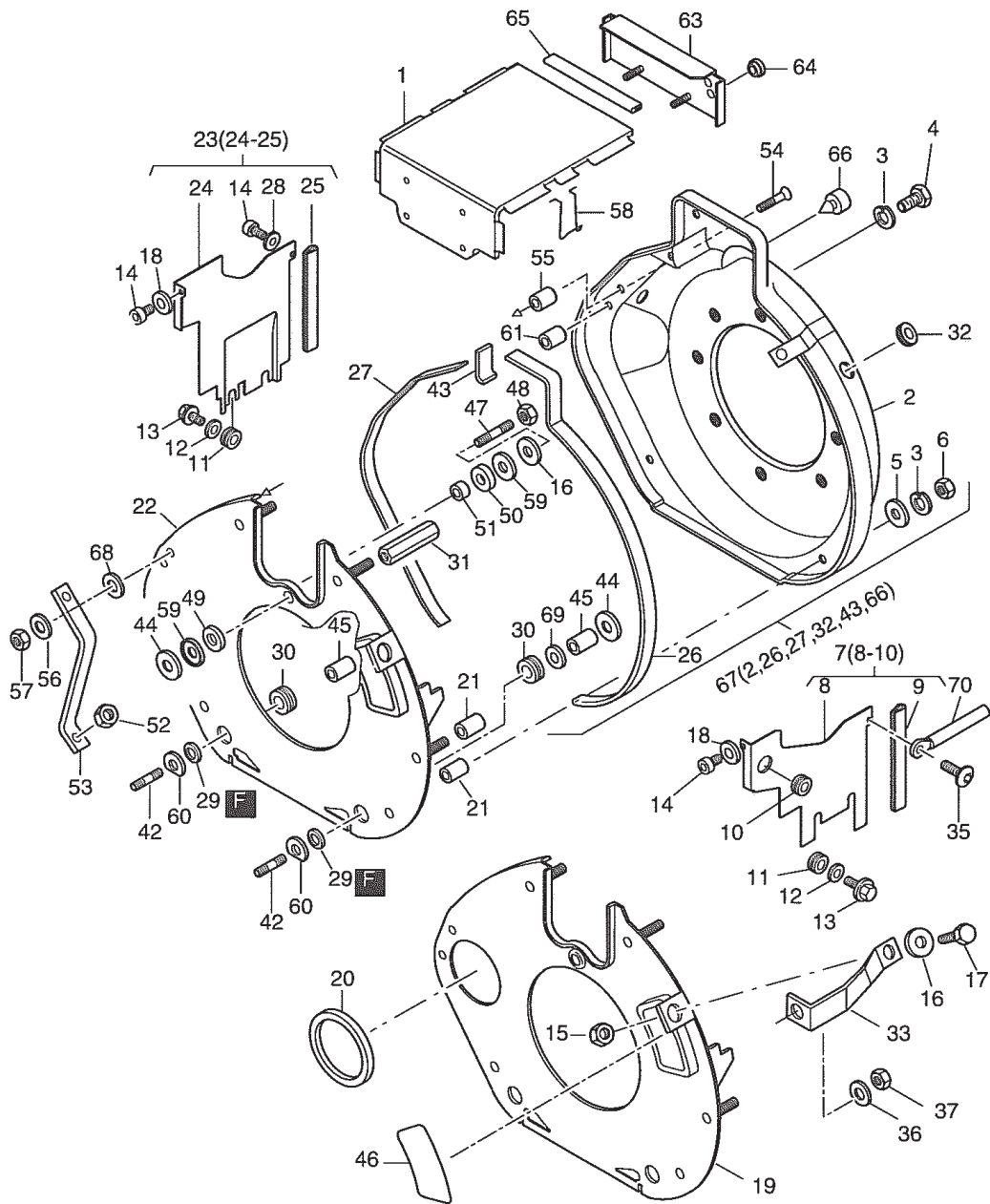

SECTION 16 BREATHING GROUP

FIG. 1600

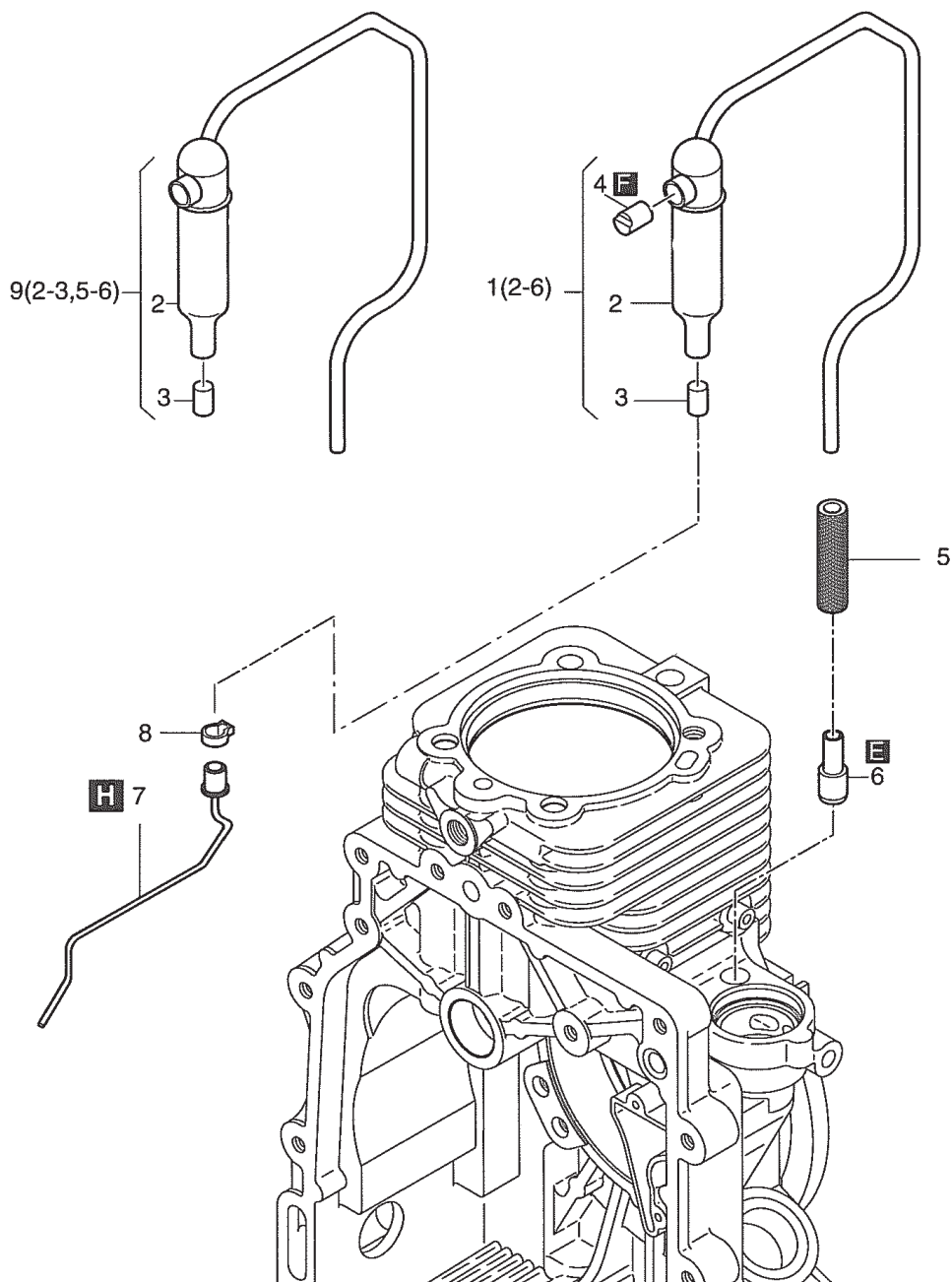

SECTION 17 FUEL SYSTEM GROUP

FIG. 1700

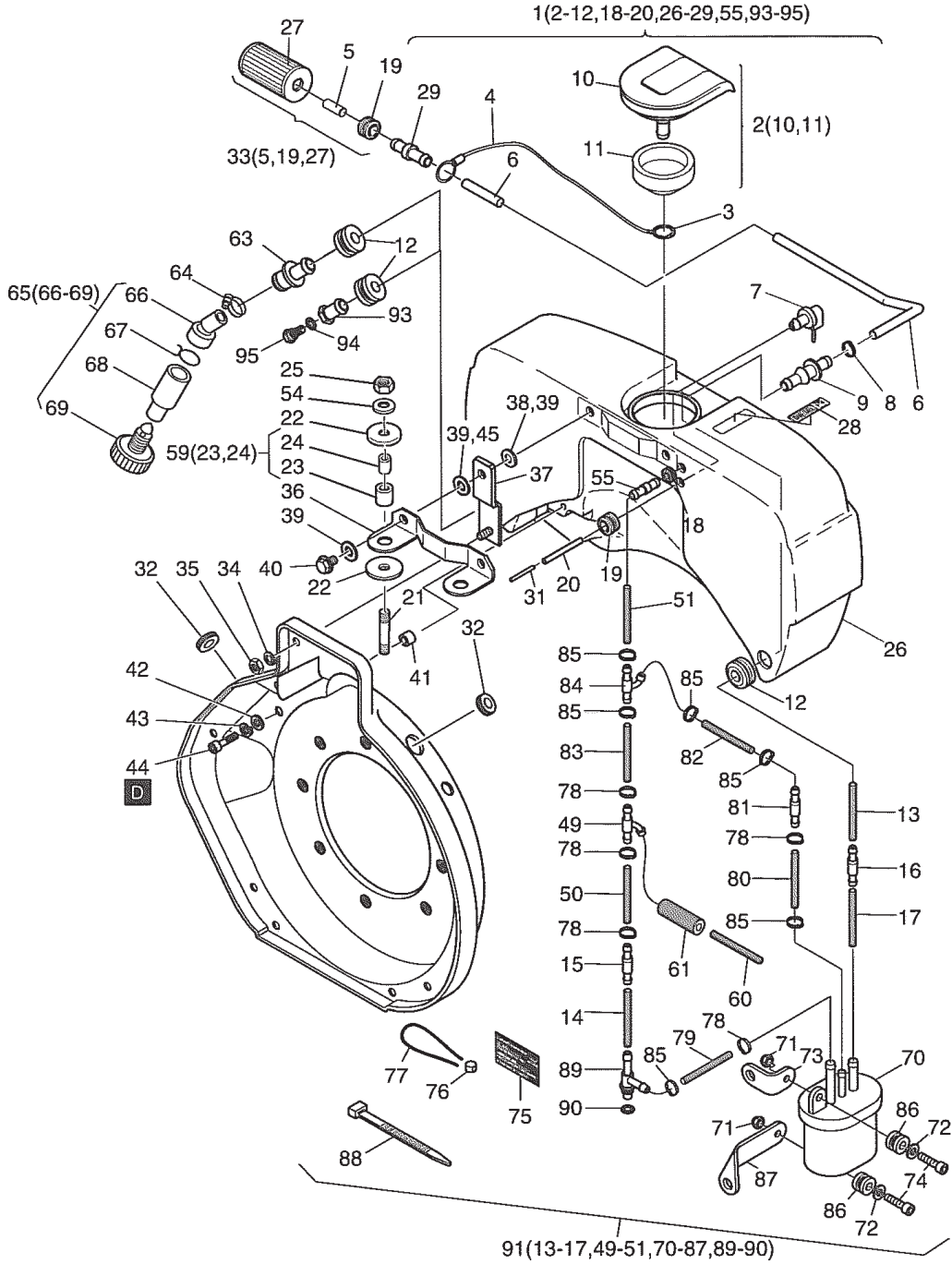

SECTION 17 FUEL SYSTEM GROUP

REF.	PART NO.	DESCRIPTION	QTY.	REMARKS	FROM-TO	FIG.
1	DH0-18529-00	FUEL TANK 5L F.SEP	1			1700
2	DH0-15353-02	CAP F. FUEL TANK	1			1700
3	DH5-05008-00	CIRCLIP 8	1			1700
4	DH0-16289-00	ROPE	1			1700
6	DH0-51899-00	FUEL HOSE 3,5X300	1			1700
7	DH0-15349-00	FUEL VENT. VALVE	1			1700
8	DH5-03998-01	CLAMP 11,3	1			1700
9	DH0-50840-10	CONNECTING NIPPLE	1			1700
11	DH0-50864-01	GASKET F. FUEL CAP	1			1700
12	DH5-04408-00	RUBBER SLEEVE	2			1700
13	DH0-52840-10	FUEL PIPE 3.5X160	1			1700
14	DH0-51232-00	FUEL HOSE 3,5 / 40	1			1700
15	DH0-15346-01		1			1700
16	DH0-53012-00		1			1700
17	DH0-36637-10	FUEL HOSE	1			1700
18	DH0-51304-00	RUBBER SLEEVE	1			1700
19	DH5-04409-01	RUBBER SLEEVE	2			1700
20	DH0-50856-00	BREATH. HOSE 1X3X85	1			1700
21	DH5-02319-00	STUD M 8X 25	2			1700
22	DH0-51098-10	DISC 8,20X22X2	4			1700
24	DH0-51228-00	INSULATING SLEEVE	2			1700
25	DH4-00284-00	HEX.NUT M 8	2			1700
28	DH0-52356-01		1			1700
29	DH0-51890-01	CONNECTING NIPPLE	1			1700
31	DH0-50855-00	TUBE 2X0,3X 16	1			1700
33	DH0-16352-10	FUEL FILTER	1			1700
34	DH5-01709-00	SPRING WASHER	2			1700
35	DH5-01444-00	HEXAGON NUT M 6	2			1700
36	DH0-51223-00	SUPPORT	1			1700
37	DH0-13313-00	SUPPORT	2			1700
39	DH0-51100-10	DISC 7,1X17,9X2	4			1700
40	DH0-16771-00	HEX SCREW M6X20	2			1700
41	DH0-41188-00	DISC 6,5X13X4,8	4			1700
42	DH5-01445-00	FLAT WASHER 6,4	4			1700
43	DH5-01709-00	SPRING WASHER 6	4			1700
44	DH5-01707-00	ALL.SCR.M 6 X 16	4			1700
45	DH5-01143-00	DISC 6,4	2			1700
49	DH0-51756-01	HOSE NIPPLE T	1			1700
50	DH0-38071-10		1			1700
51	DH0-53069-00		1			1700
54	DH5-01481-00	FLAT WASHER 8,4	2			1700
55	DH0-51844-00	CONNECTING NIPPLE	1			1700
59	DH0-16558-00	INSULATING TUBE	2			1700
60	DH0-52150-00	HOSE 2,5X195	1			1700
61	DH0-52130-10		1			1700
63	DH0-51723-00	CONNECTING NIPPLE	1			1700

SECTION 17 FUEL SYSTEM GROUP

FIG. 1700

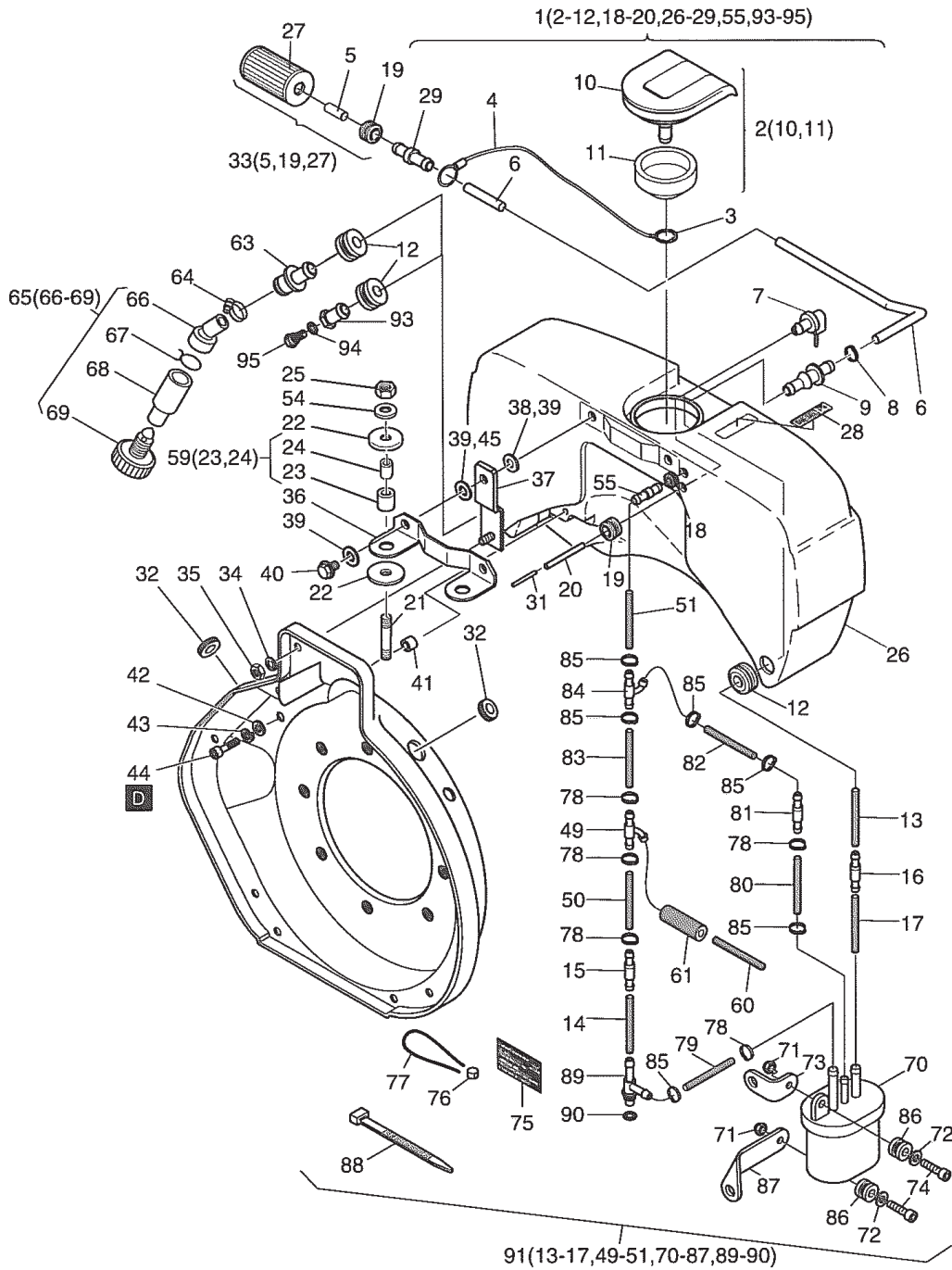

SECTION 18 AIR FILTER GROUP

FIG. 1800

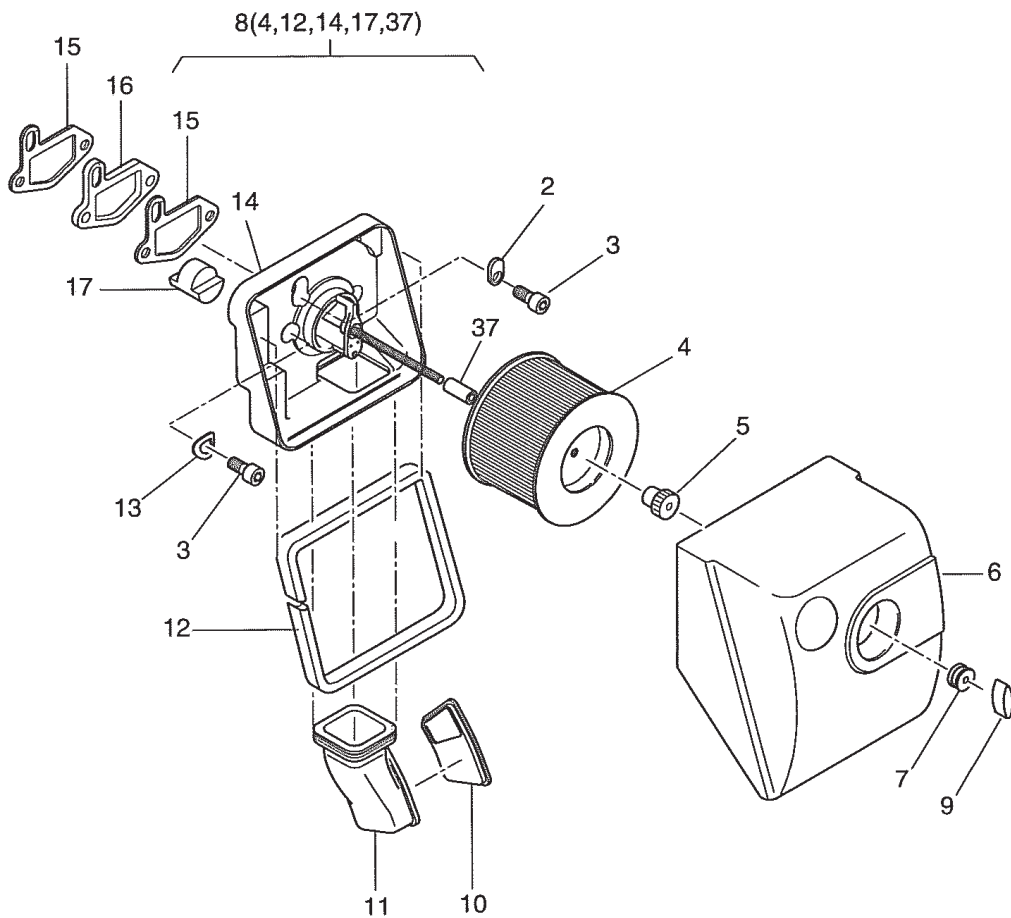

SECTION 19 EXHAUST GROUP

FIG. 1900

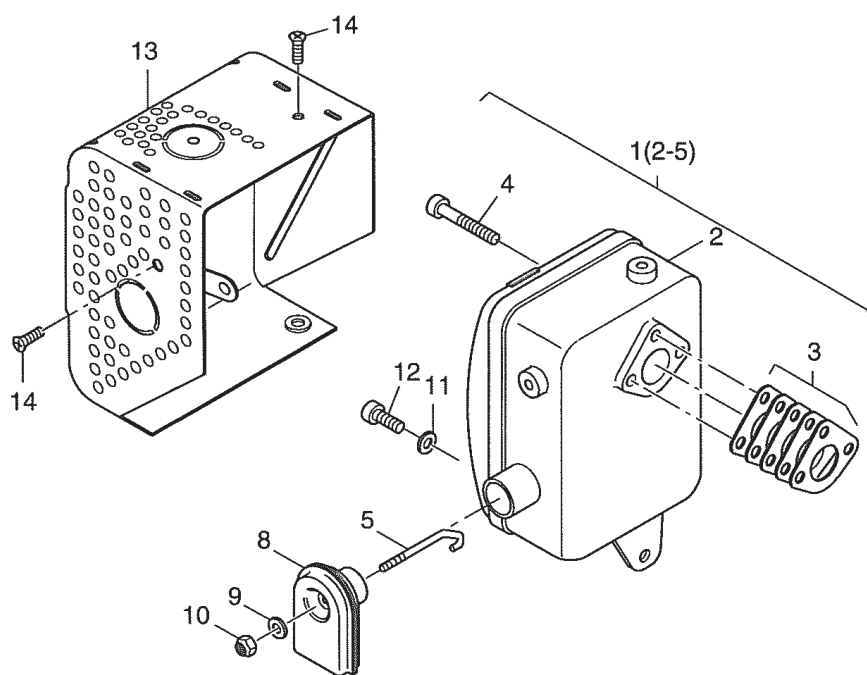

SECTION 20 STARTER, ALTERNATOR GROUP

FIG. 2000

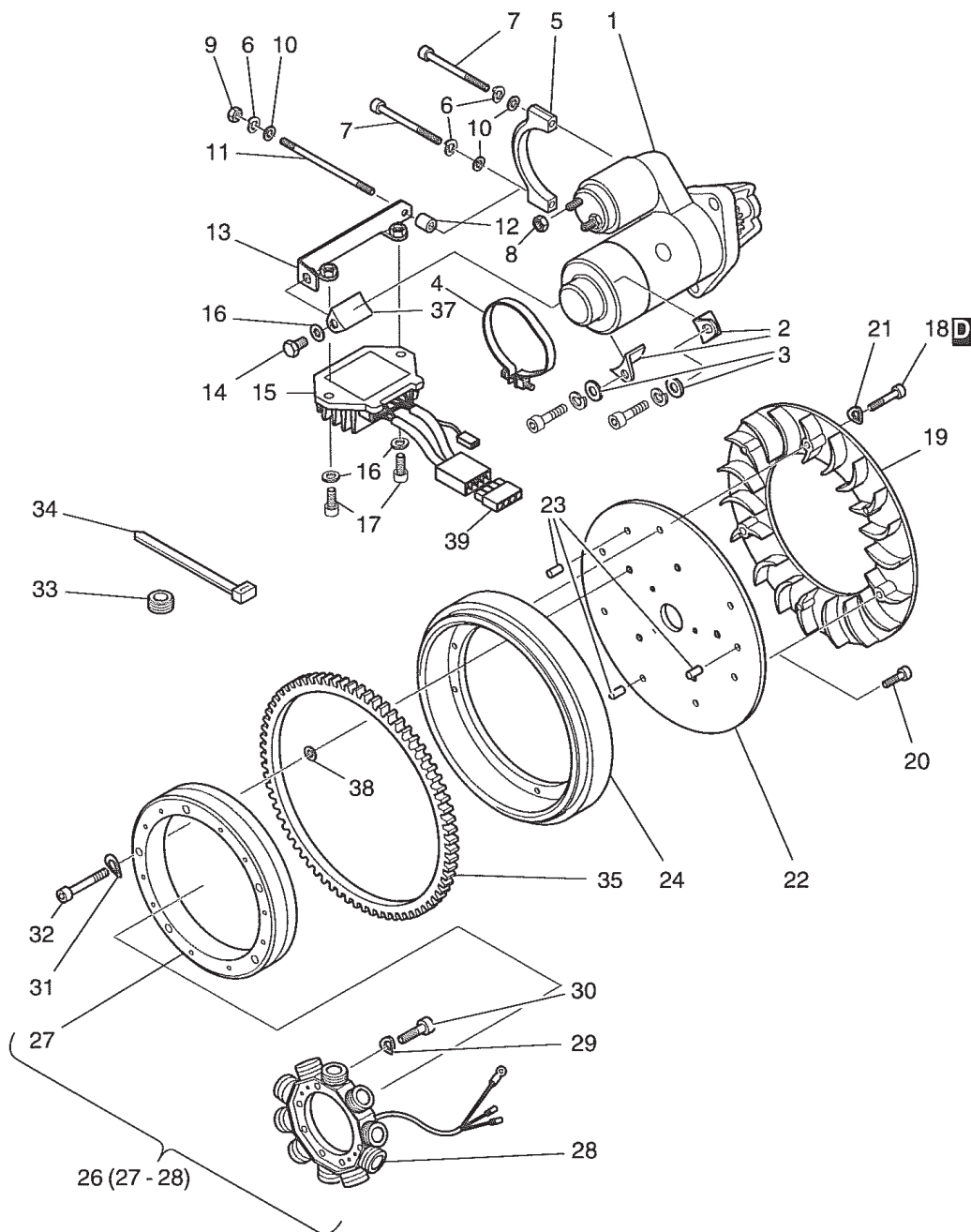

SECTION 21 ELECTRIC GROUP

FIG. 2100

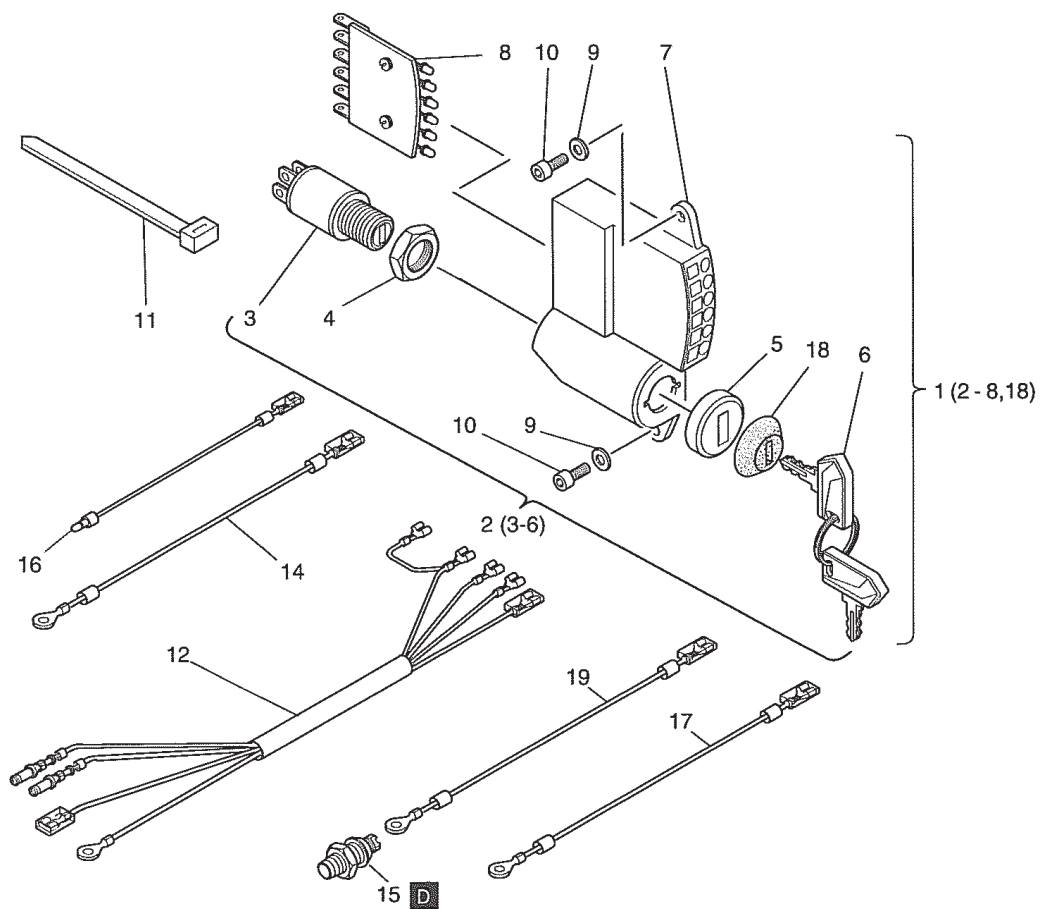

SECTION 22 SPEED CONTROL GROUP

FIG. 2200

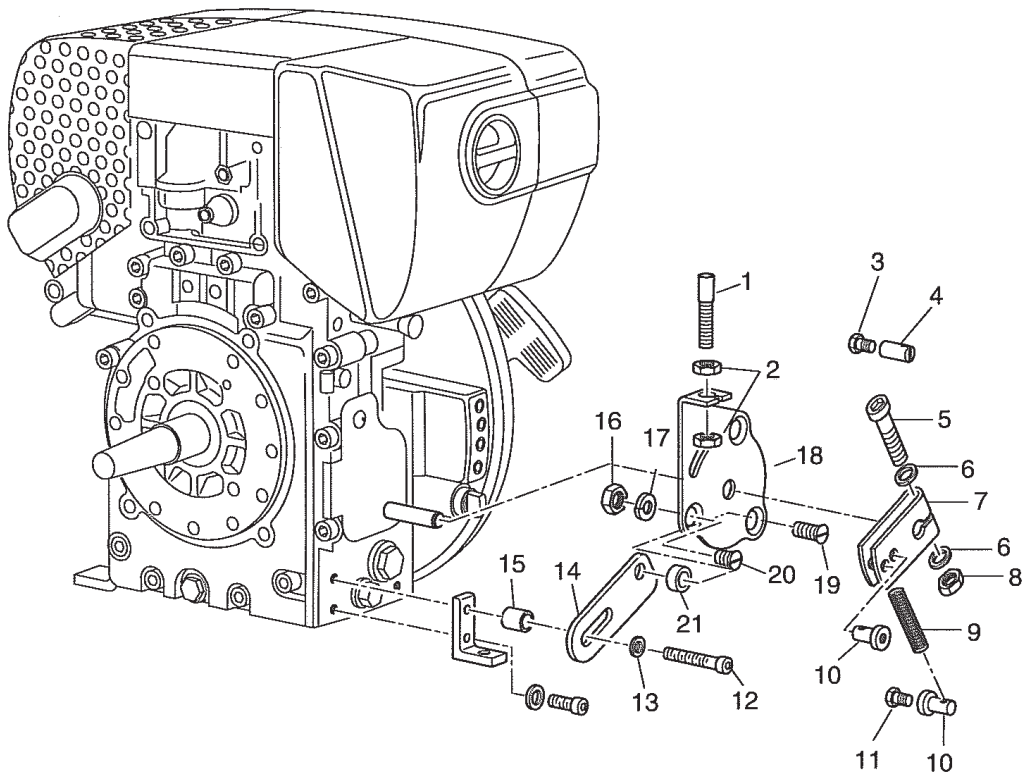

SECTION 23 STOP DEVICE GROUP

FIG. 2300

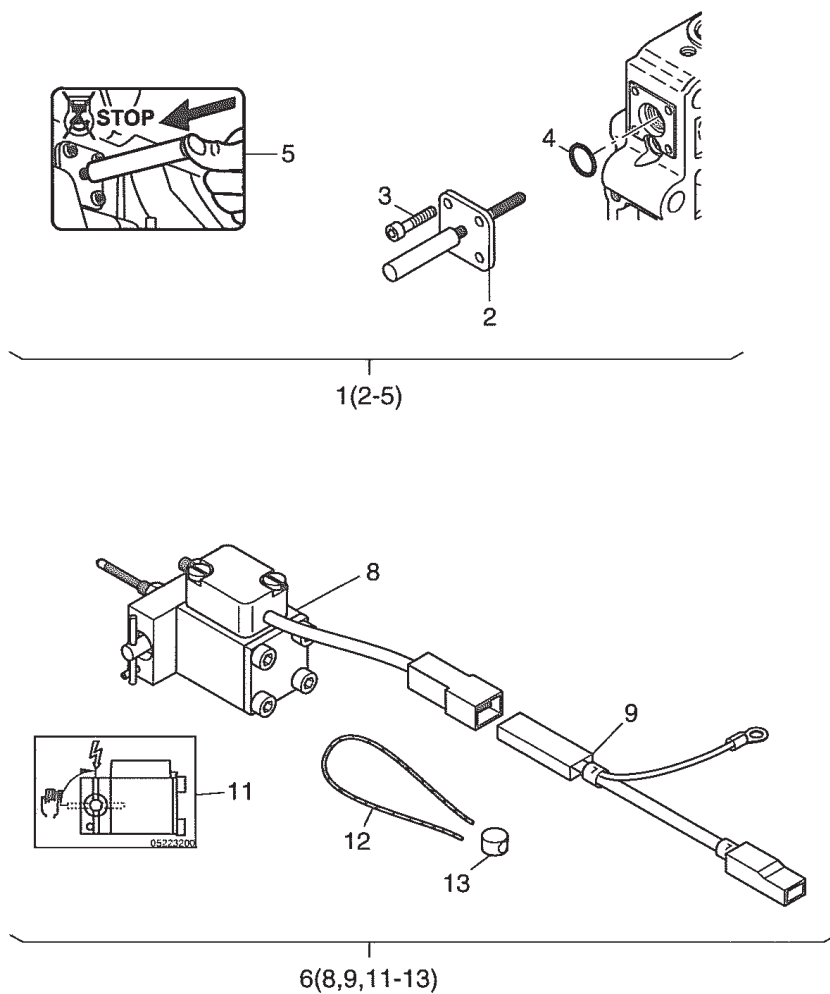

SECTION 24 SPEC. EQUIPMENT GROUP

FIG. 2400

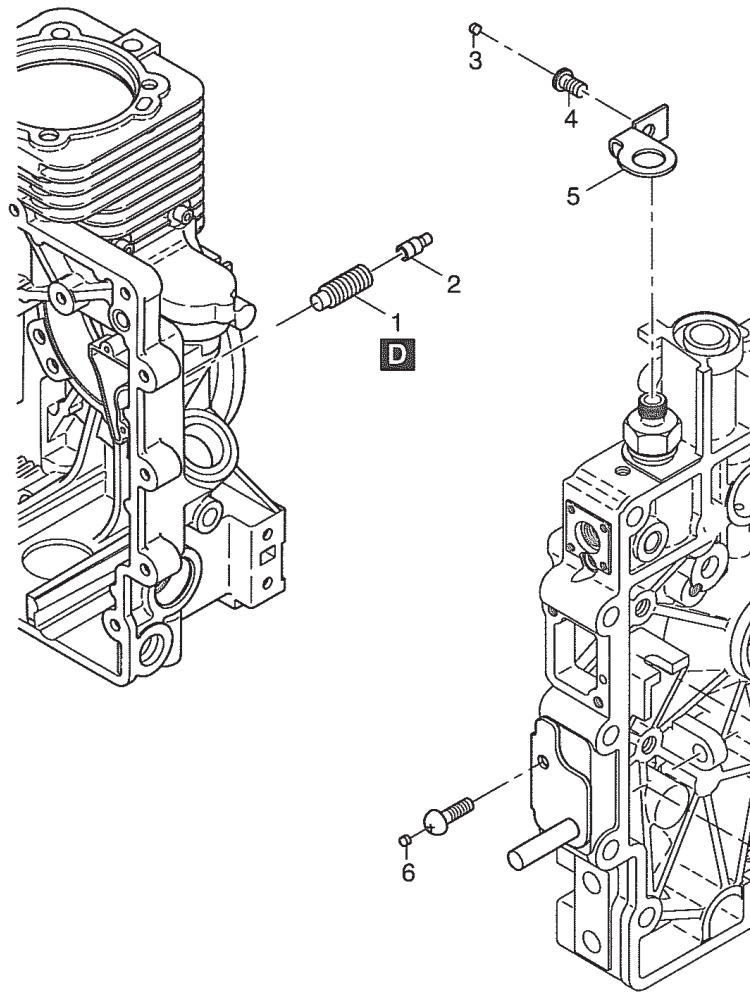

PRINTED IN THE USA