

SERVICE MANUAL

Models

**PTG109, PKV101, PKX201H,
PKX201, PKX301,
PKX201T, PKX301T,
PKX201ST, PKX301ST**

**Step by Step Procedure for Removal or
Repair of Pump Components on Subaru Robin**

Pumps

**(This Includes Mechanical Seal Replacement
and Proper Shimming)**

PUB-PS001
Rev. 09/05



SUBARU

Industrial Power Products

Robin America, Inc.

905 Telsler Road • Lake Zurich, IL 60047 • Phone: 847-540-7300 • Fax: 847-438-5012
e-mail: sales@robinamerica.com • www.subarupower.com

© Copyright 2005 Robin America, Inc.

GROUP INDEX

Group Name	Page
PTG109	4
PKV101	16
PKX201, PKX301 - Centrifugal.....	28
PKX201T, PKX301T - Trash	42
PKX201ST, PKX301ST - Semi-Trash.....	60
PKX201H - High Pressure.....	74

PTG 109

Always refer to the pump ID tag when ordering parts for the pump. The engine has a separate ID tag as well. Refer to the engine tag when ordering engine parts.

1. Remove the four outer pump housing bolts.



2. Remove the outer pump housing cover.



3. Remove the volute from the pump back plate .

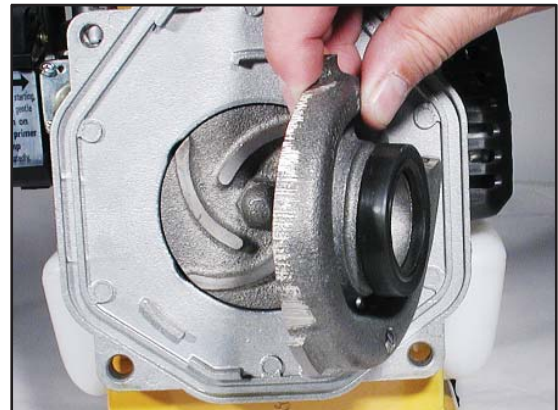

4. Remove the outer pump housing to pump back plate gasket. This will be a good time to check the gasket for cracks, tears, and overall condition. Replace if necessary.



5. Loosen the impeller by hitting on one of the blades in a counter clockwise position with a rubber mallet.



6. Turn the impeller by hand in a counter clockwise position until free from the crankshaft of the engine.



7. Pull the impeller away from the pump back plate and make sure that any shim(s) that might be positioned on the crankshaft or the impeller be saved and counted.



8. Pull the engine away from the frame.



9. For engine service work, or seal replacement, the pump back plate will need to be removed. Loosen and remove the four bolts with a allen socket or wrench.



10. Pull the pump back plate away from the engine.



11. The engine is now separated from the pump components for service.



12. To remove the stationary seal from the back plate it will be necessary to turn the pump back plate face down on the workbench. Take a 3/4 inch socket and position it into the cavity behind the seal.



13. Hit the backside of the socket until the seal drops to the workbench below.



14. This is what the seal will look like when in new condition. The sealing face will not have gouges, cracks, chips or burnt edges. Replace if any of the previous conditions apply.



15. To remove the rotating seal from the impeller it might become necessary to apply some liquid soapy water to loosen it from the impeller. After the soapy water loosens the seal in the impeller, take a small screw driver and pry gently upward making sure not to gouge the surface.



16. The impeller must be inspected for no cracks, chips, and blades that are missing or broken off. Replace with new if these conditions apply.



17. Check the condition of the volute seal for cracks, worn spots, and overall condition. Replace with new if necessary.



18. Check the condition of the volute. If cracked chipped or bent, it must be replaced.



19. When reinstalling the back plate to the engine make sure the weep hole faces downward. Weep hole must be free from debris.

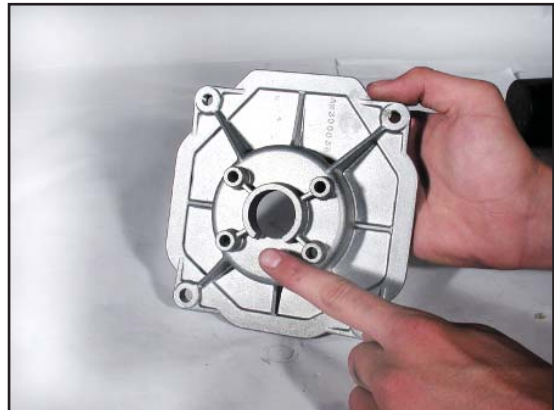

20. When replacing with a new seal, silicone compound is not needed. However, if original seal is removed and replaced back into pump back plate, then a small amount of silicone sealant will help seal it. Place a thin bead of sealant around the metal part of the seal.



21. Place the seal over the pump back plate for alignment.



22. Using a 1" inch socket, place the socket over the seal for installation.



23. After setting the seal in the pump back plate, set the socket over the top.



24. Tap the seal into position, looking at the position of the seal after each blow of the hammer to make sure it is installing evenly.



25. After the seal has been installed place the pump back plate over the crankshaft and loosely install one of the bolts to hold it in position.



26. A small amount of thread locker compound should be used on the tip of the bolts. This thread locker should be a service replaceable type such as Permatex® Blue or Purple.



27. After placing the bolts into the back plate, tighten the bolts snugly. Proper torque clearance should be 2.2 to 3.7 ft. lbs



28. If the pump came installed with shim(s) they must be replaced with same number that came off. If none were installed originally, then do not put a new shim on unless gap between impeller and volute is wider than the tolerance allows.



29. The side of the rotating seal that has the colored warning mark on it must be facing towards the impeller and not facing towards the other seal face.



30. To help installation of the seal and rubber grommet that holds it in the impeller, it might become necessary to place a little liquid dish washing soap and water around the seal to help slip it into the cavity of the impeller.



31. Using two thumbs, press the seal into the cavity making sure that the rubber grommet does not bind. The seal should be even and level.



32. Turn the impeller on the crankshaft in a clockwise position until hand tight.



33. Tighten the impeller with a rubber mallet by hitting on one of blades in a clockwise position until tight.



34. The casting marks on the pump back plate indicate where the volute must be placed. Make sure that the volute is placed correctly inside these marks.

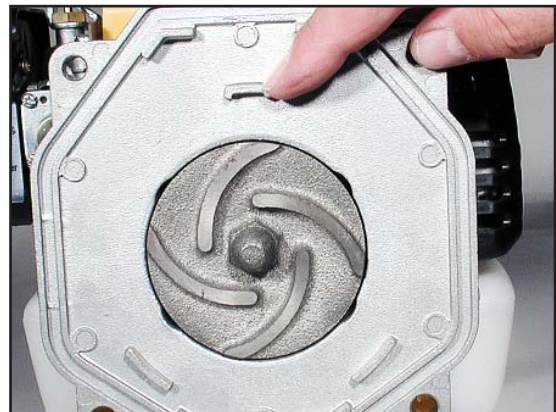

35. After installing the rubber gasket on the face of the volute, place the volute on the pump back plate. Tip the unit back slightly to hold it in position.



36. Make sure there is enough clearance between the volute and impeller, use a feeler gauge to check the gap. While holding the volute tightly against the pump back plate, insert different size feeler gauge blades until the correct reading is obtained. The recommended clearance is 0.024 to 0.039 thousands of an inch.



37. Place the outer cover over the pump back plate. It might make it easier if the pump is tipped back and the volute is in position. Do not forget the outer pump housing to back plate gasket.



38. Tighten the four bolts snugly.

The recommended tightening torque is 9 to 11 ft.lbs.

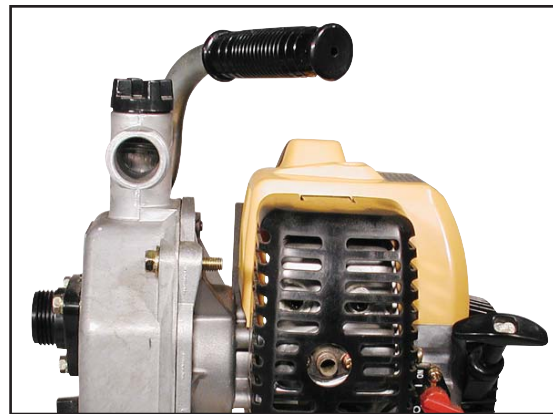

39. Should it become necessary to remove the intake nozzle, remove the three bolts that hold it in position.



40. Watch the position of the gasket and nozzle when removing from the pump housing. Also note the correct position of the gasket tab which should be facing upward.



41. This picture shows the correct placement of the gasket to the intake nozzle housing.



42. Tighten the three outer bolts, making sure not to over tighten. The gasket will be distorted and squeezed when overtightening these bolts.

The recommend tightenting torque is 3.3 to 4.8 ft. lbs.



43. Pull the engine over by the start pull cord, making sure nothing is binding in the pump.



44. After adding priming water and fuel, start the unit and check with test vacuum plate to make sure there are no vacuum leaks.

The recommended vacuum reading at sea level should be 25 lbs of vacuum.



PKV101

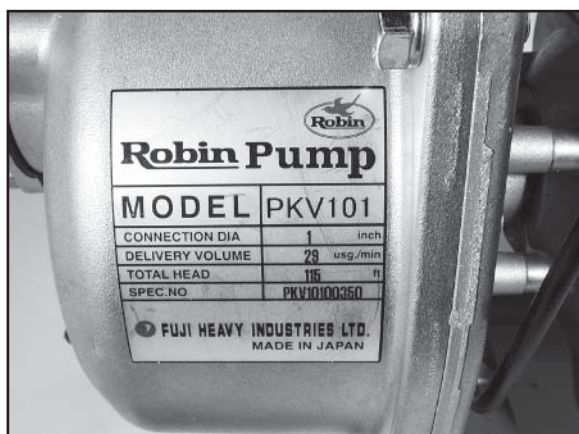

Always refer to the ID tag when ordering parts for the pump. The engine has a separate ID tag as well. Refer to the engine tag when ordering engine parts.

1. Drain any water from the reservoir and remove the 4 bolts that hold the outer casing to the pump back plate.

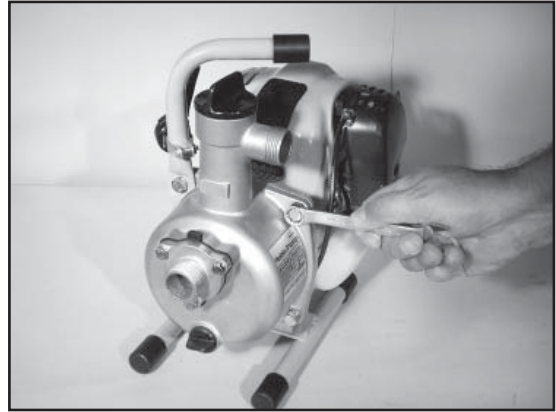

2. Pull the cover away from the back plate, keeping tipped back.



3. Note position of volute slot and outer case locating tab. This tab and slot holds the volute in the correct position. This must be positioned correctly during re-assembly.

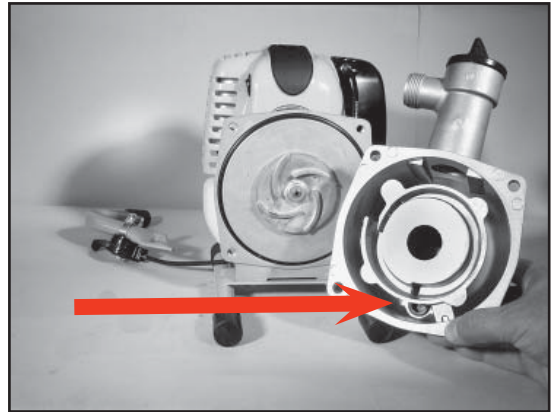

4. Remove volute from the outer pump housing, checking for cracks or any other damage that may have occurred.



5. Turn the volute over and check the O-ring for nicks or cracks. Damaged O-rings can cause loss of pump prime as well as pumping performance.

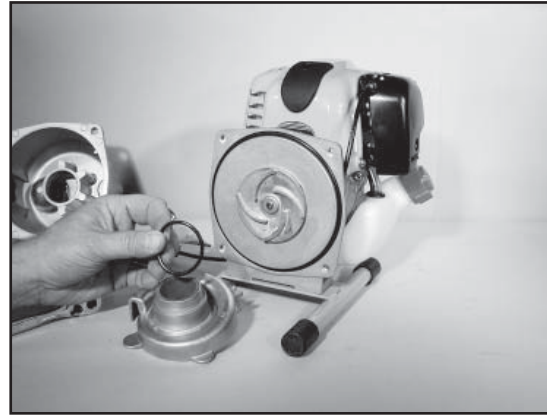

6. Check O-ring on the back plate for nicks or cracking. It should be soft and pliable. When reinstalling, clean surfaces free from corrosion, and apply dish washing soap for easier installation.

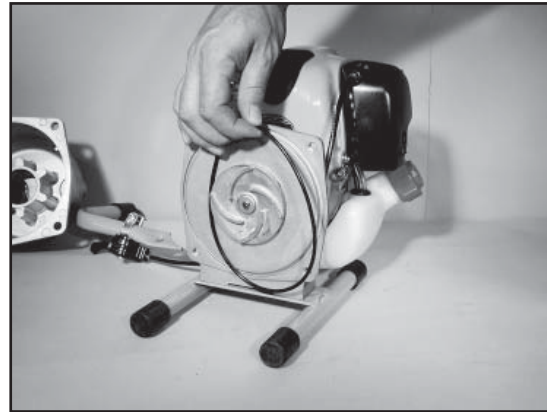

7. Remove impeller by hitting one of the blades counter-clockwise with a soft mallet.

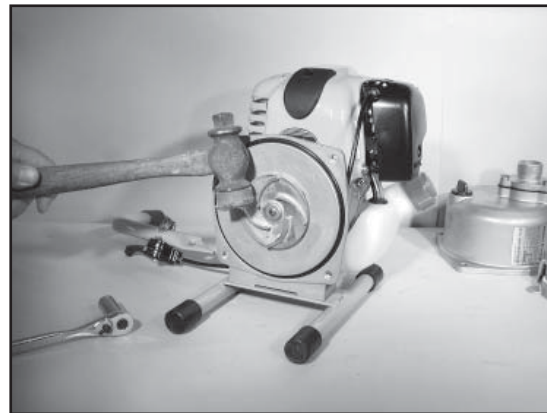

8. After the impeller is broken loose, slowly turn the impeller counter-clockwise. Make sure any loose parts, such as the spring and shims do not drop out when the impeller comes off the crankshaft.

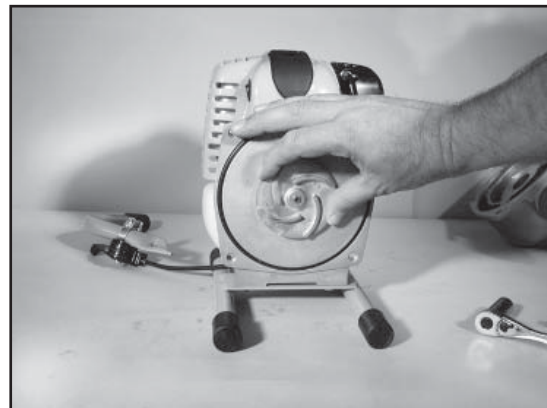

- 9. Inspect the impeller for cracks in the casting or chips in the blades.



- 10. Remove the spring and set aside.

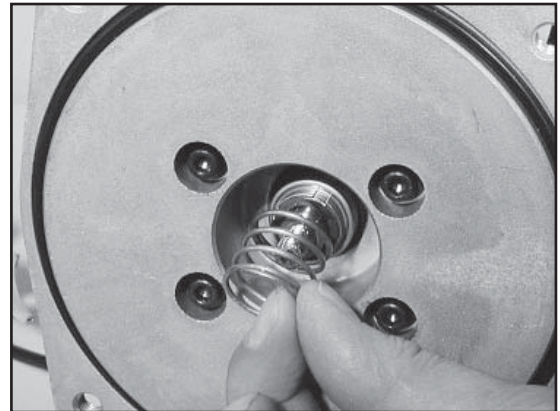

- 11. The shim(s) should be located over the crankshaft in this position.

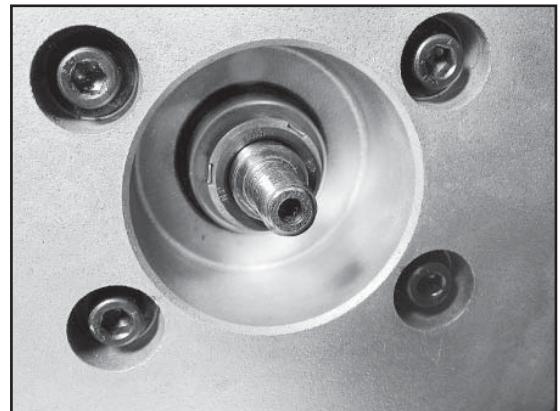

- 12. Remove the shim(s). Count the number taken off and make sure to replace the same amount when reinstalling.

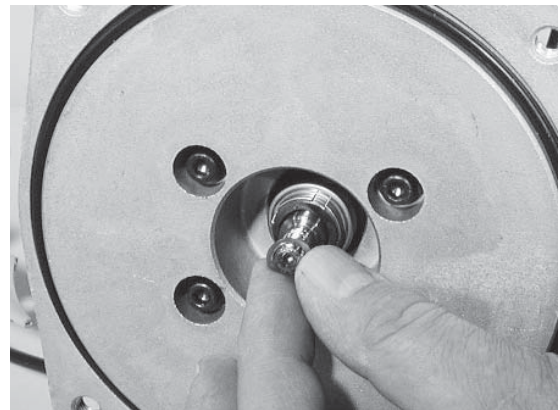

13. It is possible that the shim(s) will get stuck to the inside of the impeller housing. Take a small screwdriver and slowly remove, trying not to bend or distort. Re place with new shim(s) if necessary.



14. Squirt some liquid detergent or soapy water on the shaft and seals. This lubrication will keep the seals from tearing when removing.



15. Remove the outer seal very carefully with a pliers.

Note: Do not squeeze the seal. Place a small amount of dish washing soap or light oil on the crankshaft to keep the sealing lip from tearing.

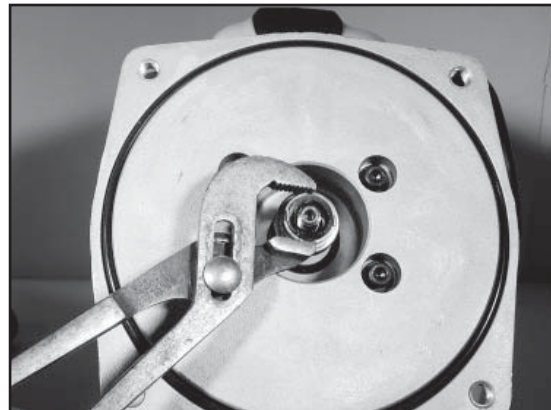

16. Inspect the outer rotating seal surface for cracks, nicks or burn marks.

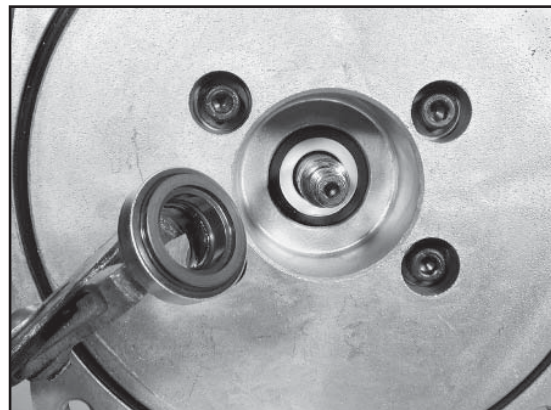

17. Carefully pry the stationary seal outward, using two screwdrivers if necessary. Note: if the seal is stuck in casing it may become necessary to squirt a small amount of liquid soap and water on sealing surface to loosen seal . It also may become necessary to remove the back plate to push the seal out when prying from the front does not work.

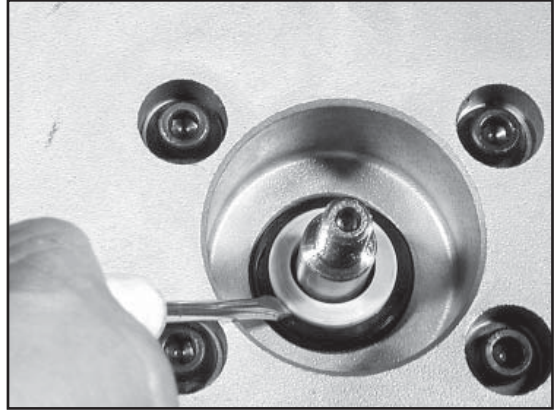

18. Inspect both halves of the seals for imperfections and replace as necessary.



19. If it becomes necessary to remove the frame and back plate from the engine for engine service remove the two bolts that hold the frame to the bottom of back plate.

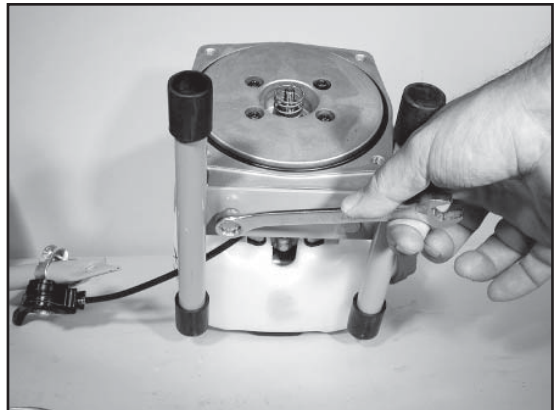

20. Remove the four bolts that hold the back plate to the engine.

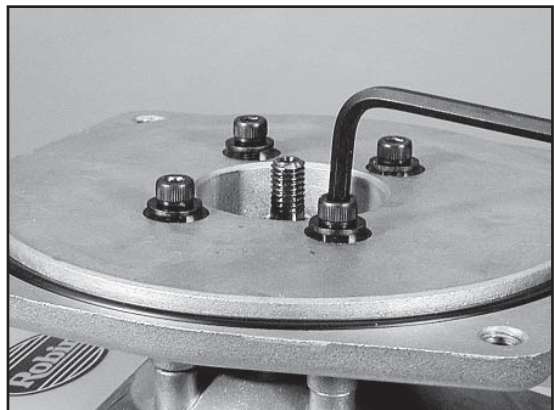

21. The engine is now free from the pump components for easier servicing if necessary.



22. When reinstalling the back plate, make sure that the weep hole points downward.

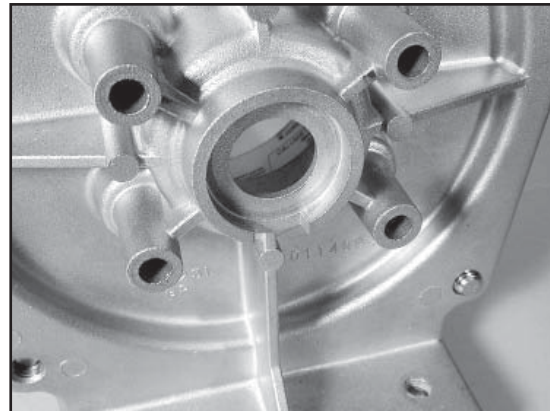

23. Place a small amount of thread lock sealer on the tip of the bolts before reinstallation. Note: Thread locker Blue or Purple from Permatex® is recommended. It is a light or medium strength, and service removable.

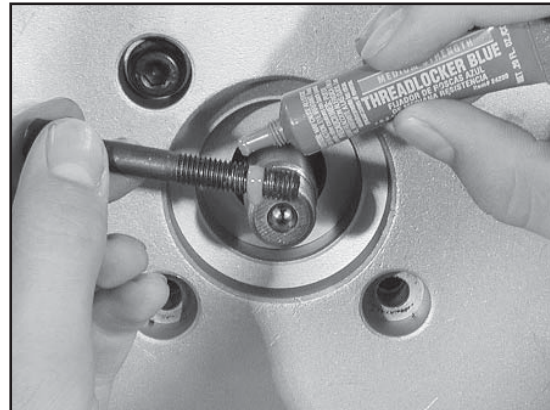

24. Reinstall and hand tighten the bolts that hold the back plate to the engine. Inspect the sealing washers that are attached to the bolts. Replace as necessary if cracked or worn.



25. Torque the 4 bolts to the specified value.

The recommended torque is 7-9 ft. lbs.

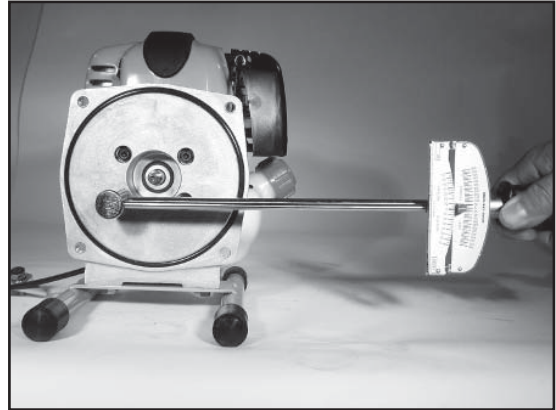

26. Position the frame under the back plate for reinstallation

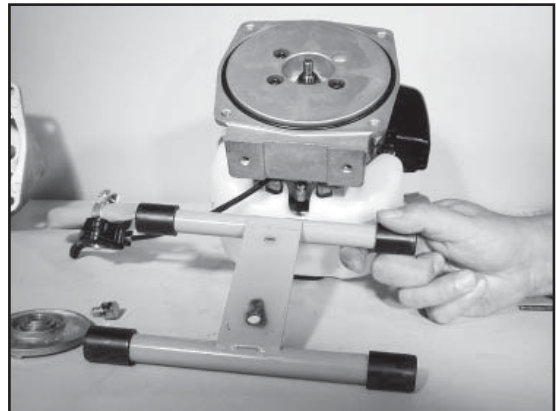

27. Install and tighten the two bolts that hold the frame to the back plate.

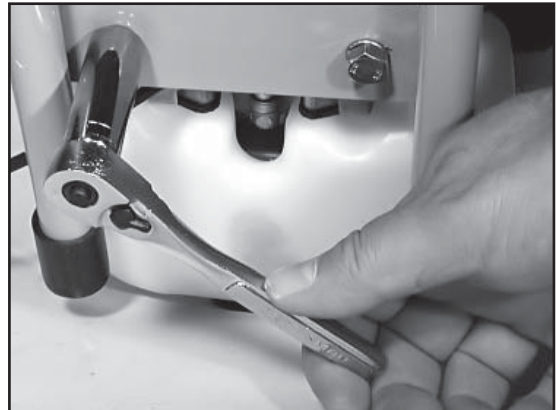

28. Squirt a small amount of liquid detergent on the seal and crankshaft before trying to reinstall. The detergent acts as a lubricant for the rubber seal.

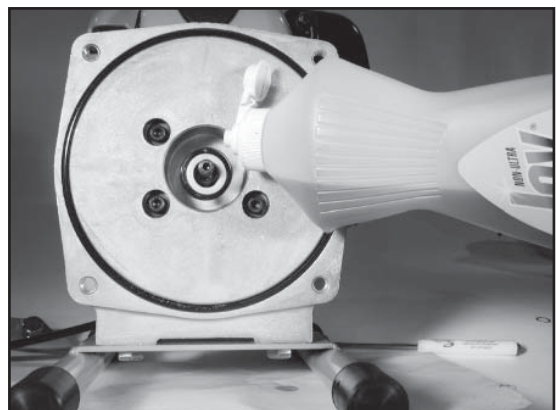

29. The seal will have some colored marks indicating that this is the back side. Do not install towards the rotating seal. The marks should face the engine.

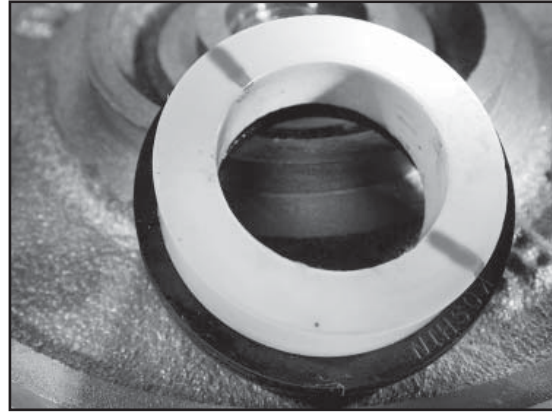

30. Push the mechanical seal into the cavity making sure it is seated properly and even. Using your two thumbs works great. If the backplate was removed, then install the seal into the backplate before putting on crankshaft.

Note: Lubricating with a small amount of soap detergent and water will ease installation significantly.

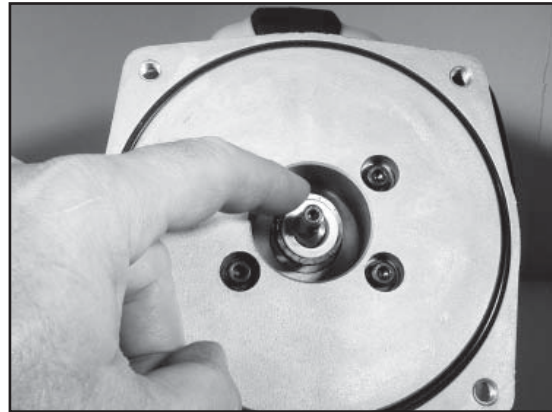

31. Re-install the other half of the seal. by pushing tight against the other half.

Note: Lubricating with a small amount of soap detergent and water will ease installation.

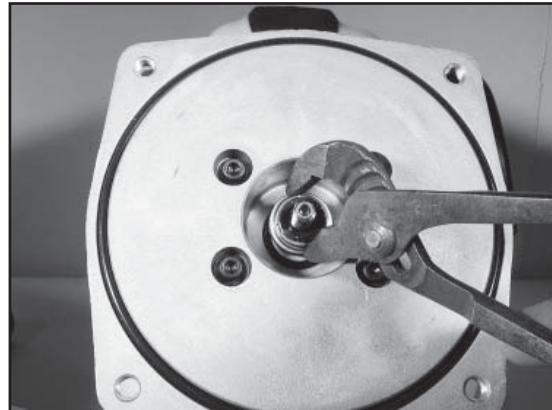

32. Re-install the spring. It can be installed in either direction.

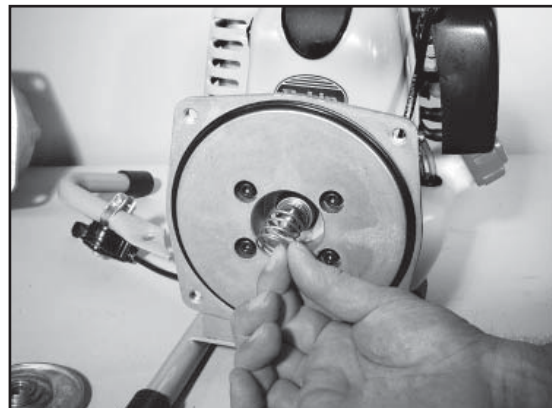

33. Re-install the shim(s) making sure you replaced the same number that came installed with the pump. If a new component such as a impeller or volute was installed, refer to the section on proper shimming.

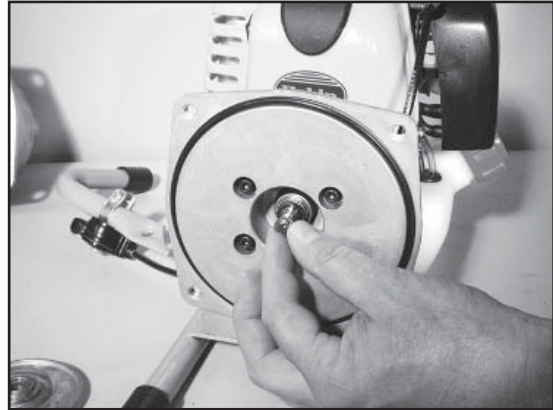

34. Screw and snug the impeller hand tight on the crank shaft, making sure it is flush with the back plate.

Note: If shims are not properly installed onto crankshaft, the impeller will not fit flush to backing plate. If this condition occurs, remove impeller and push the shims onto crankshaft further, making sure the shims are not bent out of shape.

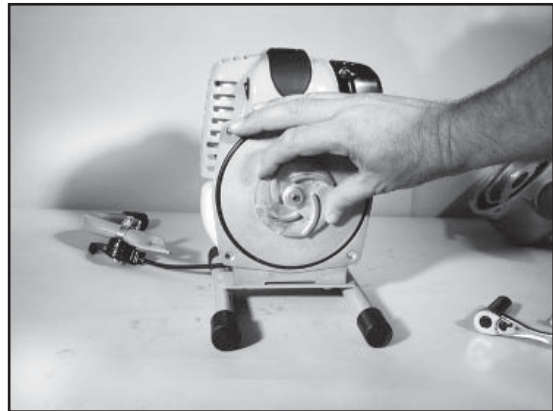

35. To insure the impeller is installed correctly, place the volute against the back plate. While holding the volute tight against the back plate with one hand, check the clearance between the volute and impeller with a feeler gauge. If the clearance is larger than 0.040 thousands of an inch, then another shim must be added.
The recommended clearance is 0.020 to 0.040 thousands of an inch.

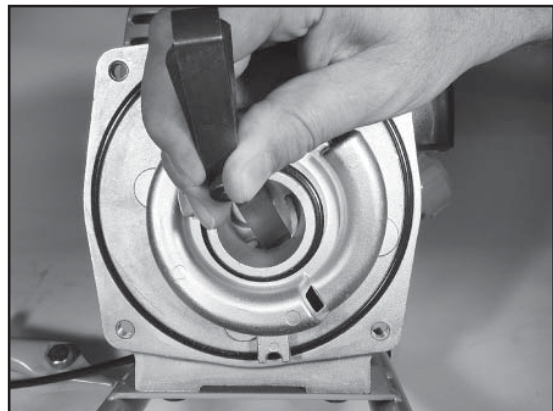

36. If shims need to be added or subtracted then remove the volute and impeller, taking note of how many shims were added or subtracted. Re-install impeller and check again. After proper clearance is obtained install impeller once again.

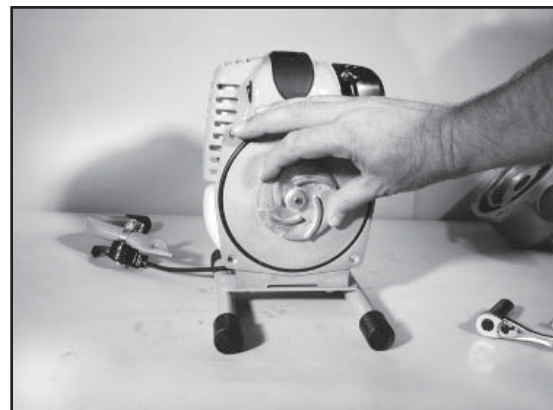

- 37.** Tighten impeller with rubber mallet by hitting on one of vanes until snug.

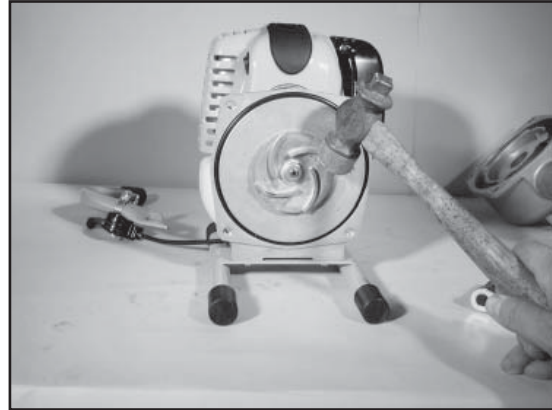

- 38.** Install the volute into the outer pump housing making sure to put the volute slot into the tab that is embossed in the outer cover. Check the outer o-ring condition as noted earlier.

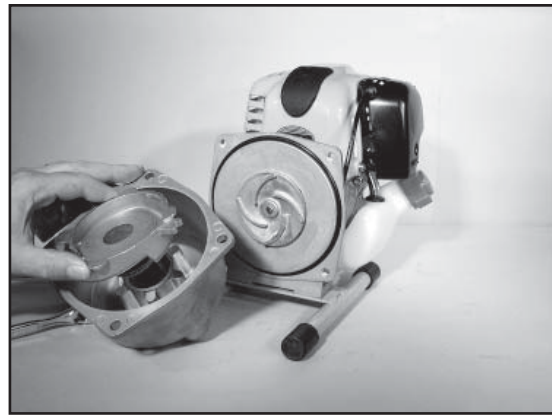

- 39.** Re-install the cover and volute onto the back plate with the four bolts.

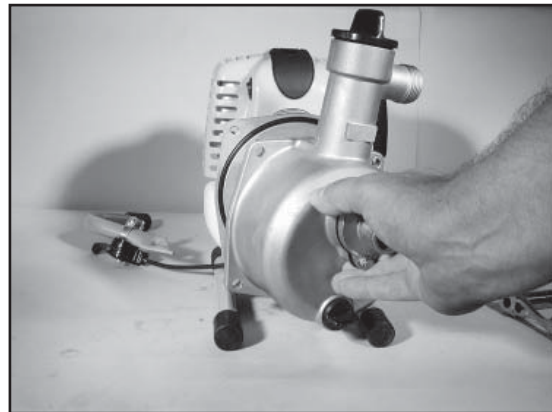

- 40.** Tighten all bolts and fill with prime water. The proper torque value for these bolts is 9 to 11 ft. lbs.

Check engine oil and test for proper vacuum with vacuum plate tester. The vacuum gauge should read 25 lbs of pressure.

Note: See test procedures under separate heading.

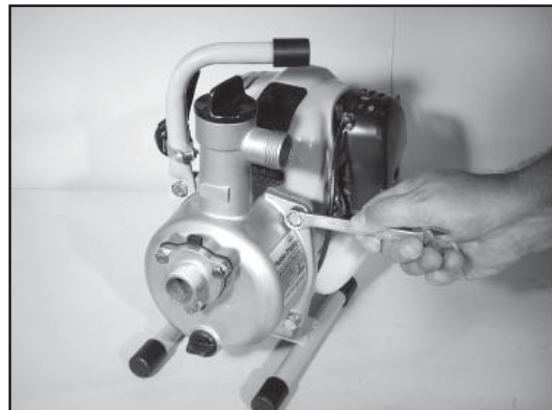

- 41. Should it become necessary to remove the inlet nozzle and gasket, follow these steps. Remove the three bolts that hold the inlet nozzle to the outer pump case.

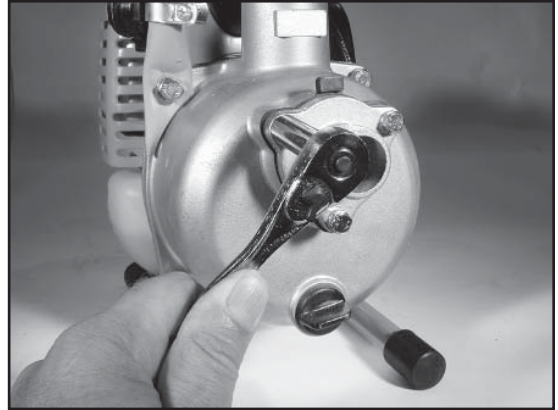

- 42. Inspect the check valve gasket, noting that there is a correct way to install it.

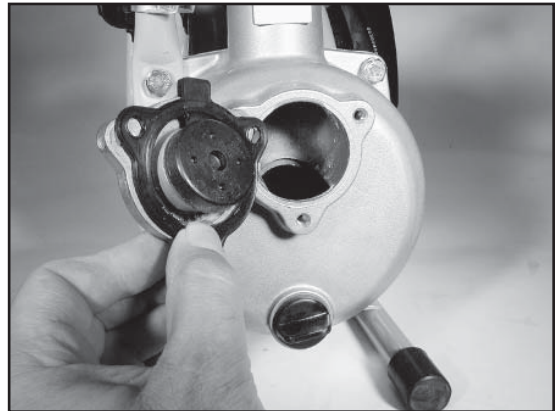

- 43. Picture show the correct installation of the check valve gasket on the inlet nozzle. When reinstalling inlet nozzle it is important not to over tighten.

The correct torque value is 2 to 3 ft lbs.



- 44. The picture shows the correct position of the gasket tab facing upwards.

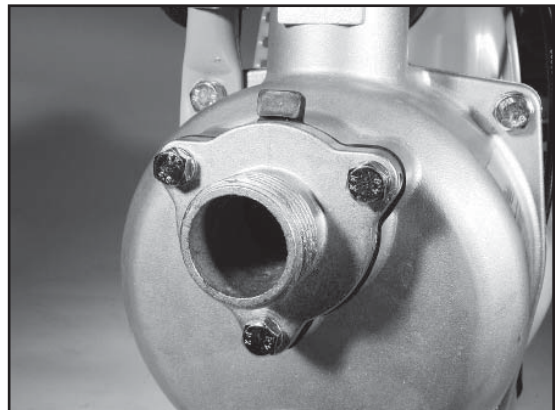

PKX 201 Centrifugal

PKX301 Centrifugal

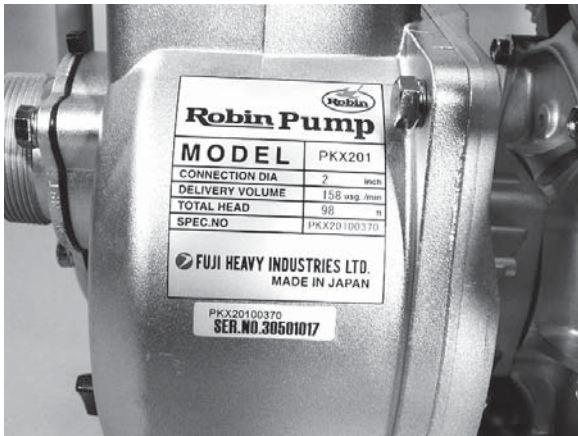
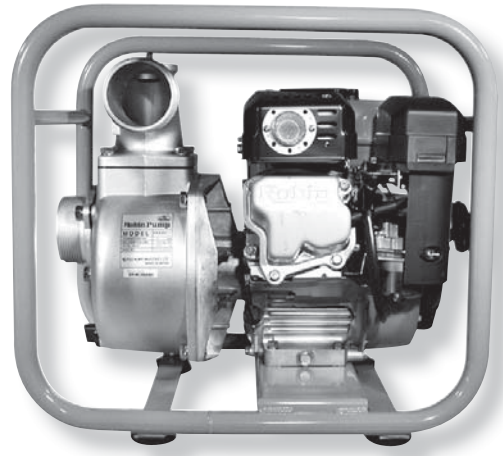
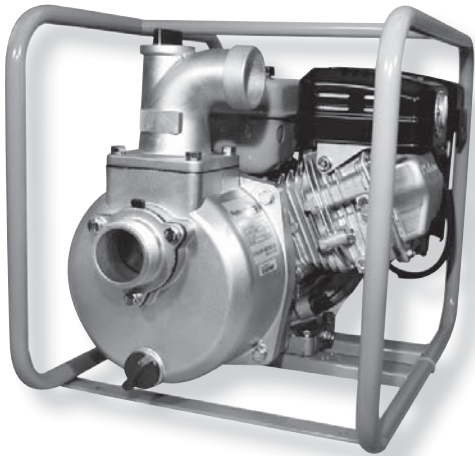

Always refer to the ID tag when ordering parts for the pump. The engine has a separate ID tag as well. Refer to the engine tag when ordering engine parts.

1. Drain water from the reservoir and remove the 4 bolts that hold the outer casing to the pump back plate.
2. Remove outer casing and volute as an assembly. Tip backwards not allowing the volute to drop out of the casing.
3. Note the locating slot that is cast into the volute. This must align with the notch cast into the outer casing when re-assembling.
4. Tip the outer casing on its back and pull out the volute. If the O-ring, on the back side of the volute causes the volute to stick when trying to remove, use two hands to lift out the volute, while holding the outer casing

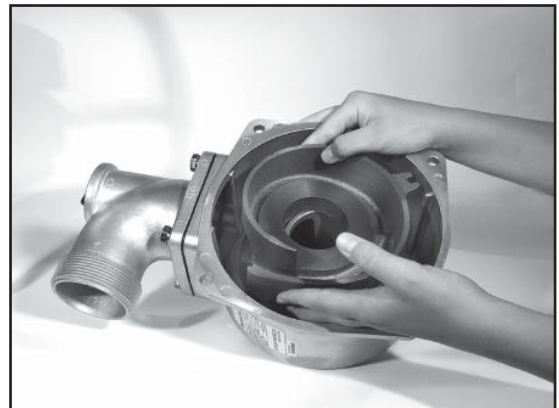
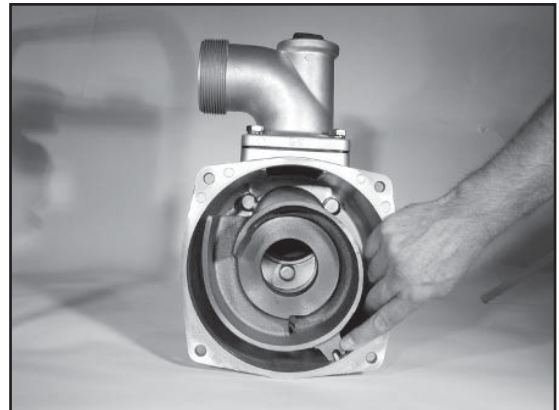
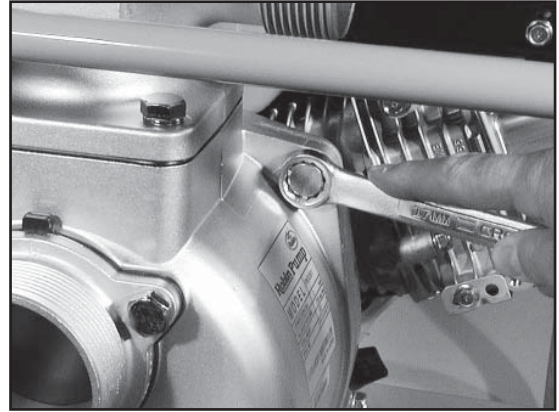

5. Inspect the volute for damage. Check for cracks and bent castings.

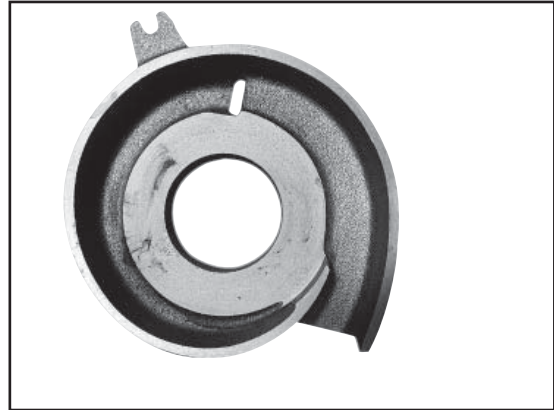

6. Check the condition of the O-ring on volute. Check for nicks, cracks and gouges. Bad O-rings could cause poor priming and loss of pump performance.



7. Remove the impeller with a hard rubber mallet. Hit one of the blades in the counter-clockwise position. It is best to not block the engine for this procedure. Only use a flywheel strap when it does become necessary.



8. Slowly turn the impeller off the crankshaft. Watch that the impeller does not drop off the crankshaft when reaching the end of the threads. Use two hands if necessary. Watch for loose parts such as the spring, or shims.

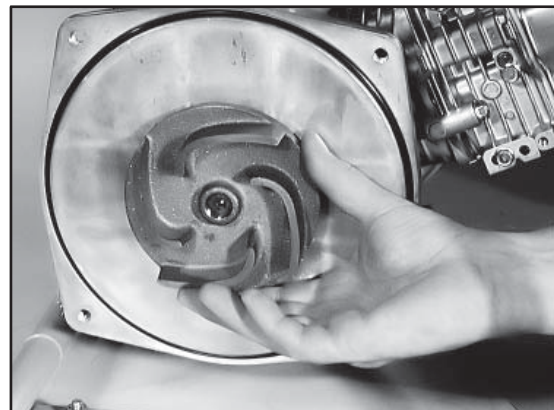

9. Inspect the impeller for defects.



10. Carefully remove the spring from the crankshaft. It can be replaced in either direction.



11. Remove the shim(s) from the crankshaft. Count the number that is used and replace with the same amount. Should the impeller or volute be replaced with new, it will become necessary to re-shim according to the re-shimming guide located in service manual



12. If the shim(s) get stuck inside the impeller. Carefully pry the shim(s) out with a small screwdriver. If shim(s) get bent or are flattened beyond use, replace with new one(s).

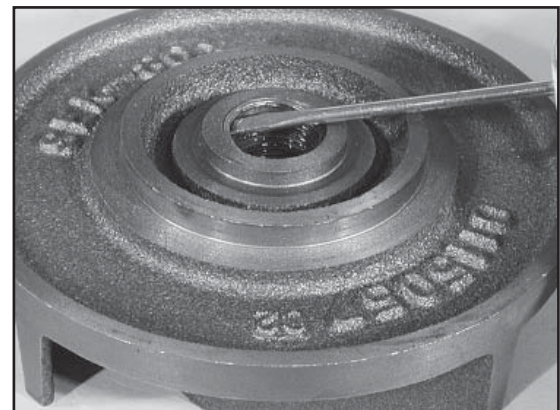

13. This is what the shims will look like if in good condition.



14. Before trying to pull the rotating seal half (carbon side) off the crankshaft, it might become necessary to clean the crankshaft with an emery cloth. Applying soapy water to the crankshaft, as well as on the seal, will help prevent the sealing lip from tearing when removed.

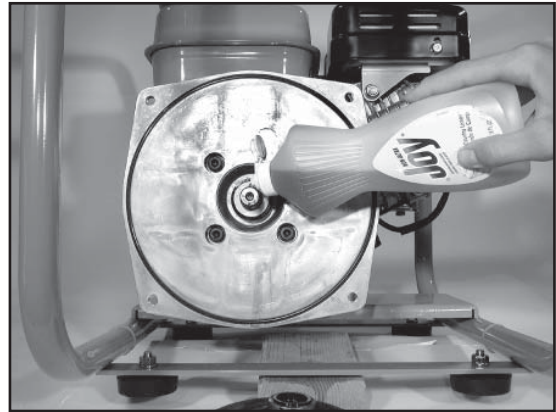

15. Using a pliers, carefully pull the rotating half (carbon side) off the crankshaft.

Note: Squeezing too hard will ruin the seal. The best way to remove the seal would entail removing the backing plate as shown in Step 22. The pulling force of the entire backplate will help remove the seal without bending or distortion.



16. After removing from pump, inspect the surfaces closely. No cracks, chips or uneven wear should show. If pump was run without water, the surface of the seals will have a worn and burnt appearance.



17. Use a small screwdriver to pry between the ceramic seal and the black rubber seal that holds it in place.

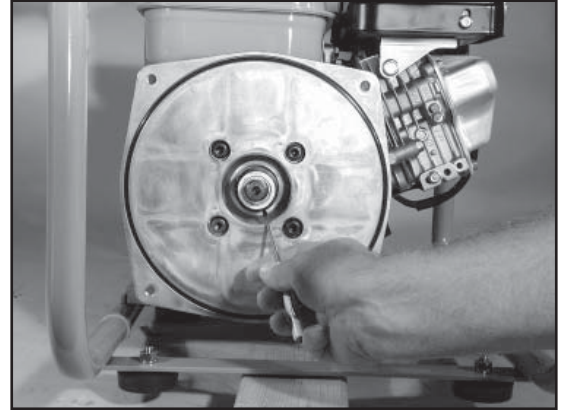

18. If the seal seems to be stuck, squirt some liquid soap on the seal. This will loosen it from the black outer rubber seal. Using one or two screwdrivers, pry the seal outward. It may become necessary to remove the pump backplate when the seal is stuck. See step 22 for removal of backplate.

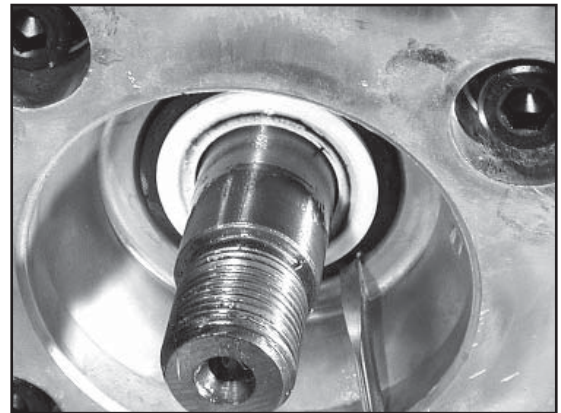

19. This is what the seal will look like when removed.

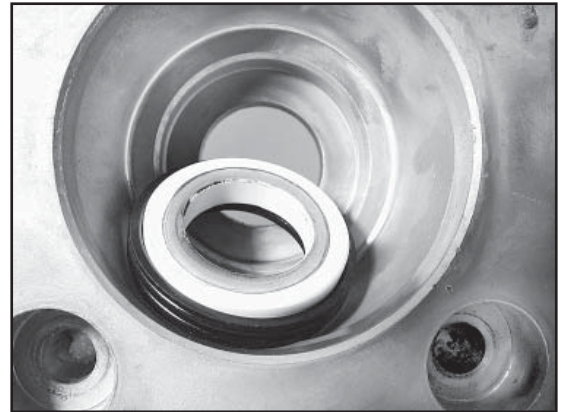

20. Make sure never to use the back side of a seal when reinstalling. The back side of the seal will usually have some colored marks indicating it is the wrong way.

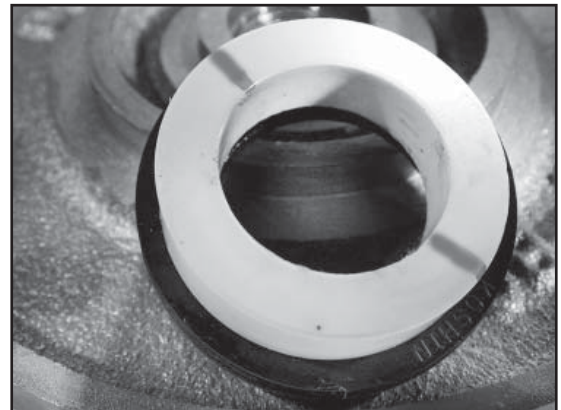

21. This is a good time to check the condition of the o-ring that seals the outer housing to the back plate. Check for nicks, cracks, and replace if necessary with new.

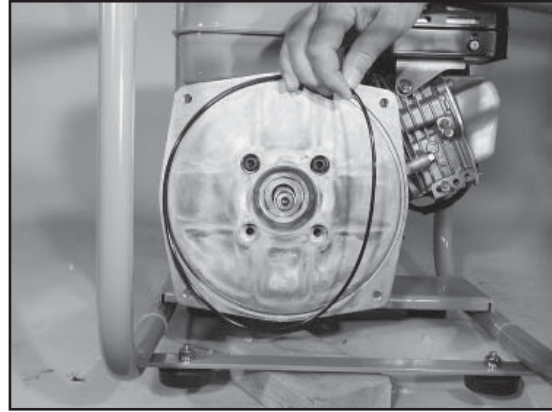

22. It may become necessary to remove the back plate for servicing the engine. Use an Allen wrench to remove the 4 bolts that attach it to the engine.

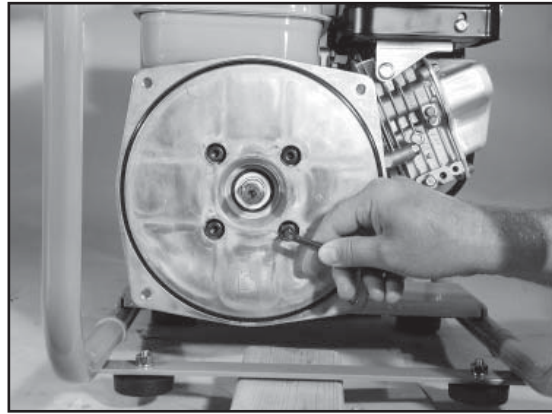

23. Lift the back plate out of the way and inspect for damage.

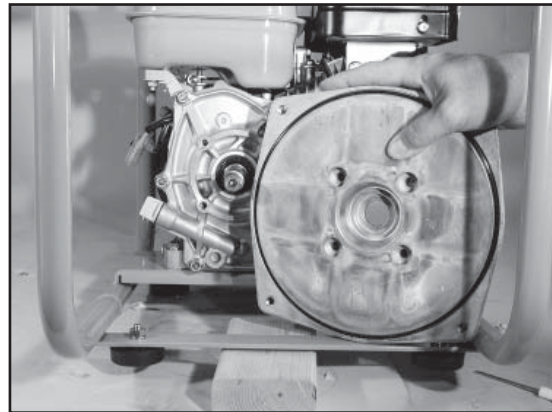

24. If it becomes necessary to remove the engine from the frame, remove the four bolts that hold it to the base plate of the pump frame.

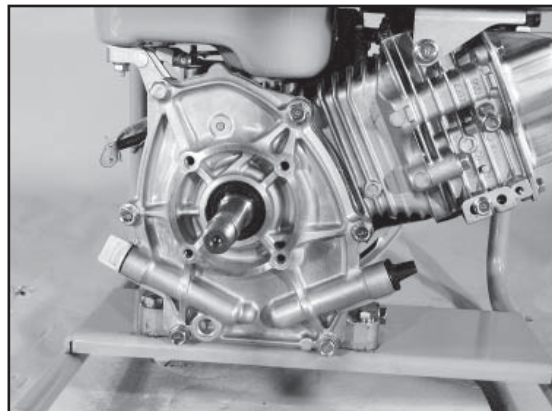

25. When reassembling the back plate to the engine make sure the weep hole is facing towards the bottom of frame. The weep hole is to prevent water from entering the engine should a mechanical seal fail.

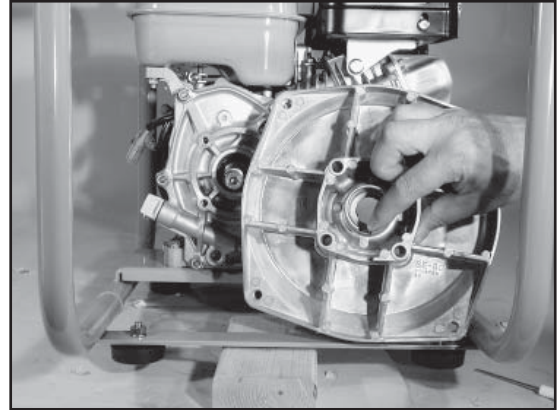

26. Install the pump back plate onto the engine. Install with one bolt to hold its position.

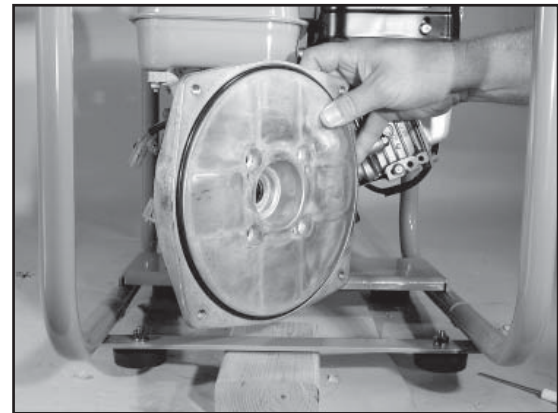

27. Place a small amount of thread lock sealer on the tip of the bolts before reinstallation. This will prevent the bolts from loosening.

Note: Only use Allen head bolts and special sealing washers. Washers should fit snug around the bolt. Inspect for cracks in the sealing surface. Replace with new if needed. Note: Threadlocker Blue® from Permatex is recommended. It is medium strength and service removable.

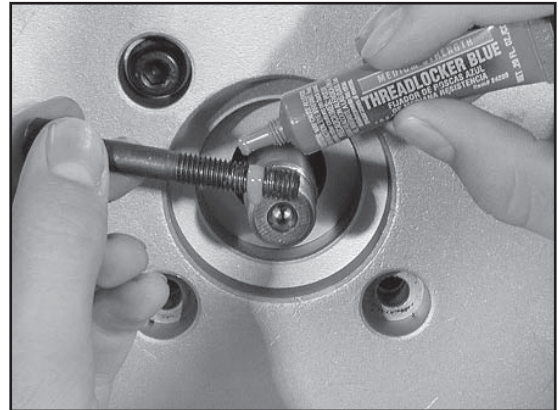

28. The four bolts should be tightened snugly by hand. Tighten diagonally to ensure even installation.

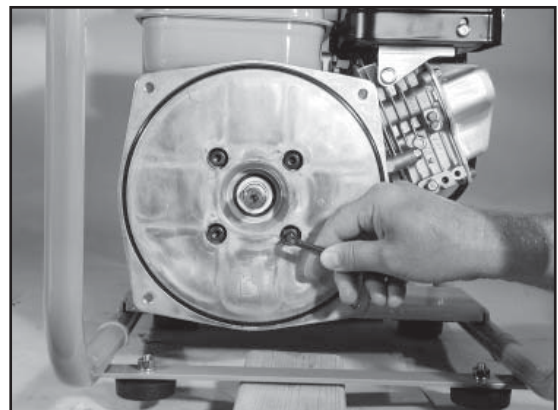

29. Using a torque wrench with a special Allen socket, torque the bolts to a specified value of 12 to 15 ft. lbs.

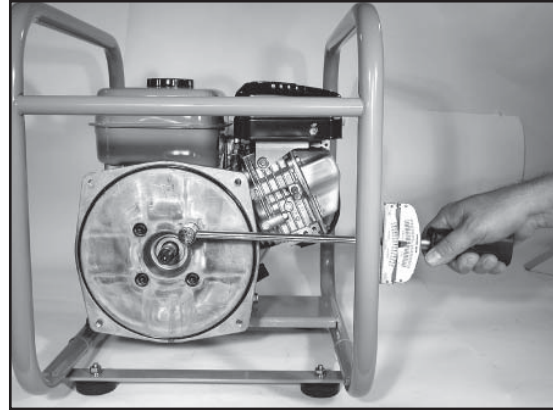

30. Push the seal on with two fingers or, use your two thumbs. Making sure it is seating correctly.

Note: If the backplate is removed for whatever reason, it would help to install the seal before installing the backplate onto the engine.

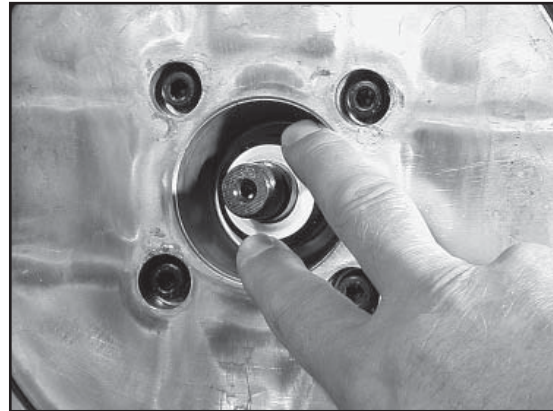

31. Reinstall the rotating half of the mechanical seal.

Note: Placing a small amount of soapy water on the sealing lip will aid in reinstallation and keep the seal from tearing.



32. Re-install the spring in either direction.



33. Re-install the shim(s) using the same number as was taken off. If new components such as impeller or volute was used, it may become necessary to re-shim with new shims for proper clearance.
34. Hand tighten the impeller onto the crankshaft. Make sure it is threaded on all the way. If the impeller is not threaded to the full extend, the impeller face could strike against the inside of the volute.
35. To make sure the impeller is installed correctly, hold the volute against the back plate and check the clearance with a feeler gauge. If the clearance is larger than 0.040 thousands of an inch then another shim must be added. If the clearance is 0.020 or less and the pump grinds and turns over hard, it is possible that a shim needs to be removed.
36. Re-tighten the impeller with a hard rubber mallet, hitting the blades in a clockwise position. It should be tight enough that you should not be able to turn it loose by hand.

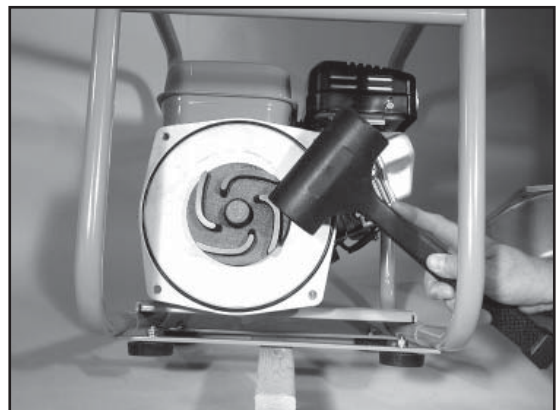
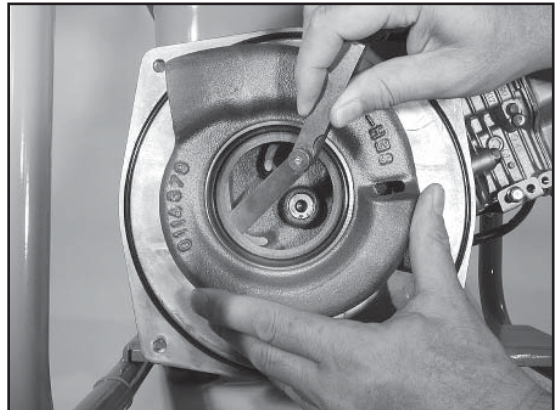
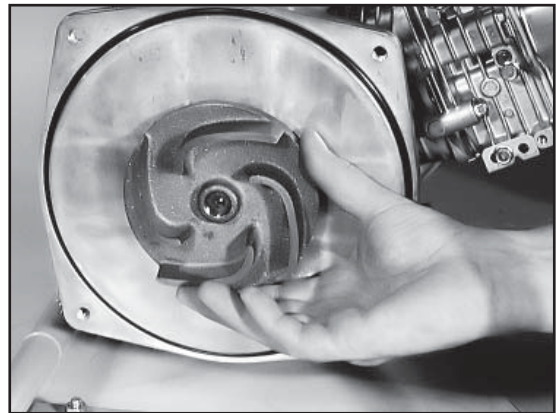
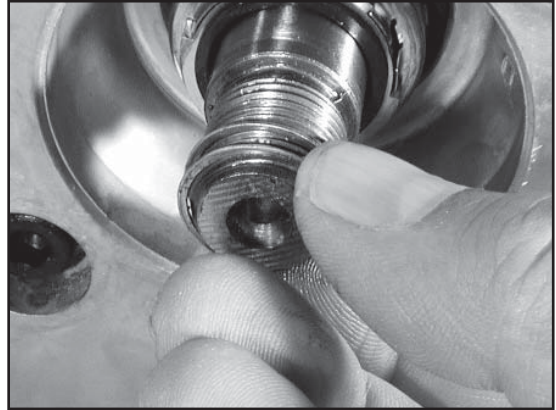

39. Re-install the volute into the outer case making sure the slot in the volute is resting on the casting molded into the outer case.

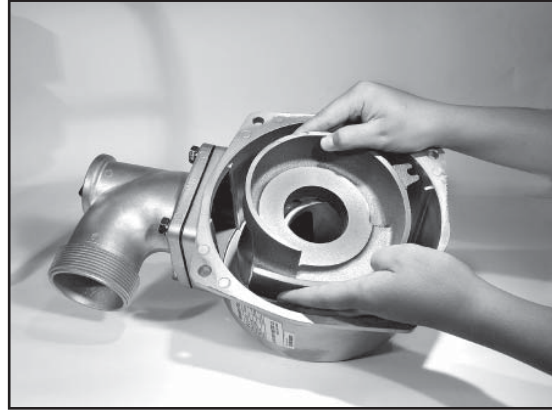

40. It is important that the volute slot matches with the cast in notch in the outer pump case.

Note: See arrow.

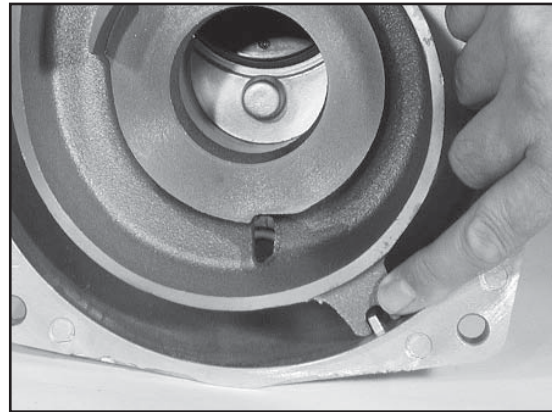

41. Replace the cover and volute onto the pump back plate. Install the four outer pump case bolts.

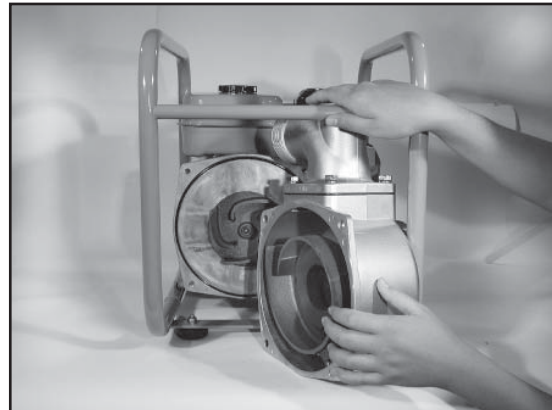

42. Tighten and torque the four bolts to:

PKX201- 9 to 11 ft. lbs
PKX301- 16 to 20 ft lbs

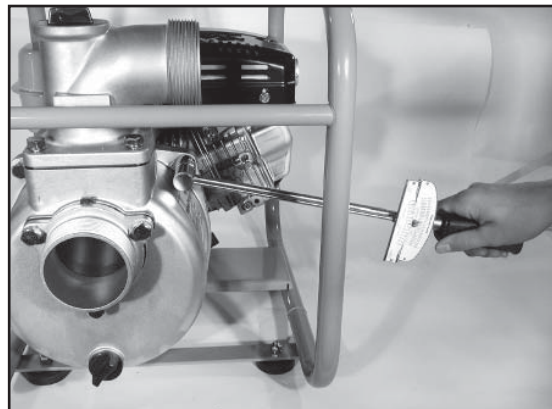

43. Once the case is torqued down, pull the recoil starter to check that pump and engine turn over freely. If OK, then re-fill with prime water. Next check the engine oil and start the engine. Apply vacuum pressure plate tester per service manual, and check for leaks.

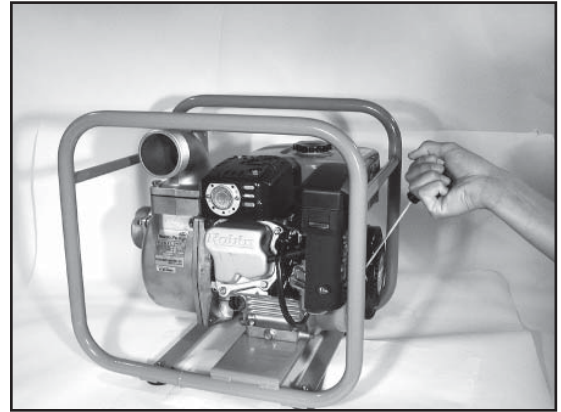

44. If it becomes necessary to remove the discharge nozzle, the following procedure is recommended. Loosen and remove the 4 bolts that hold the nozzle housing to the outer casing.



45. Remove the discharge nozzle and inspect the gasket and nozzle for cracks.

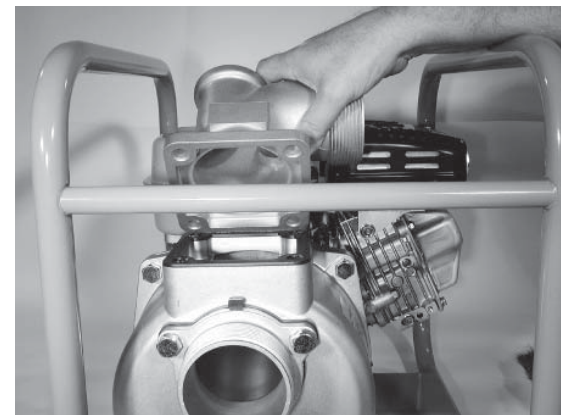

46. When replacing the gasket, make sure the gasket is flat and not kinked. The gasket does not have a specified side for placing on the pump housing.



47. Re-install discharge nozzle and torque to specified recommendations.

Torque to:
PKX201-3 to 5 ft. lbs.
PKX301-4 to 6 ft. lbs.

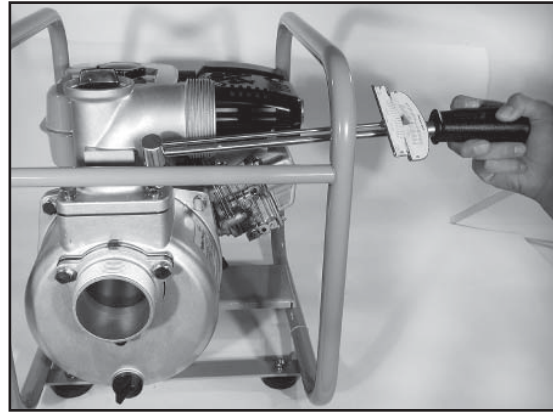

48. If it becomes necessary to remove the inlet nozzle, the following procedures are recommended. First, loosen the three bolts that hold the casting to the outer pump housing.

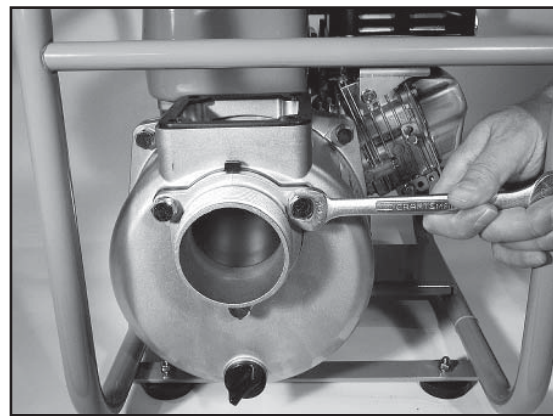

49. Next, lift the outer cover and gasket from the pump housing. Note the position of the gasket. Check gasket for cracks, nicks or other areas that might cause an air leak.

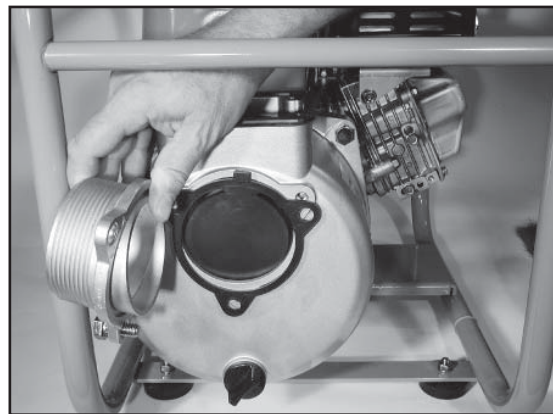

50. There is a correct way, and a wrong way to reinstall the inlet gasket. Make sure that the gasket does not have casting marks facing outward.

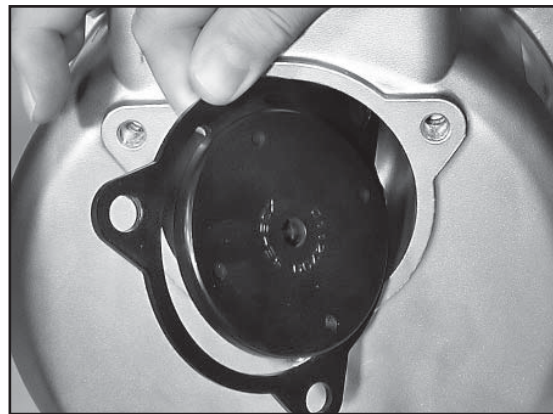

51. This picture shows correct way to install the gasket. Make sure the gasket is flat against the outer housing when reinstalling cover. Align holes and thread the three bolts into the nozzle and cover.



52. After reinstalling bolts, torque to the specified torque value.

Note: The gasket tab pointing upward showing correct placement of gasket.

Torque to:

PKX201- 3 to 5 ft lbs.

PKX301-5 to 6 ft lbs.

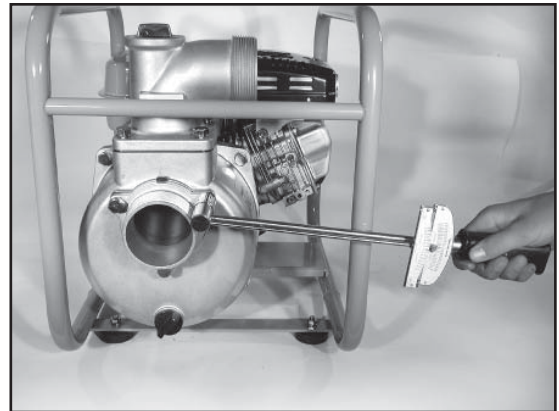

PKX201T

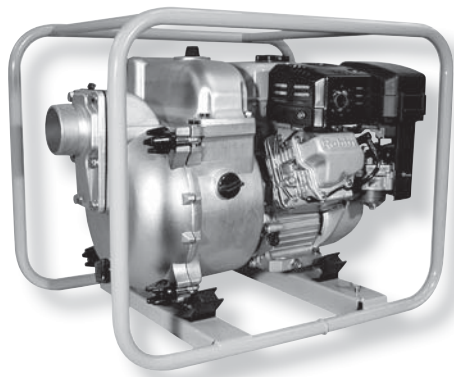

PKX301T

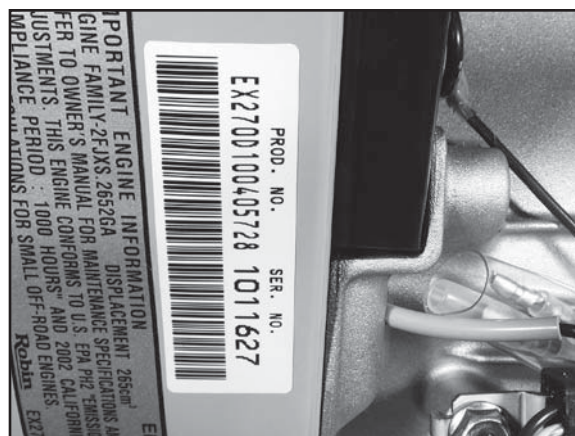
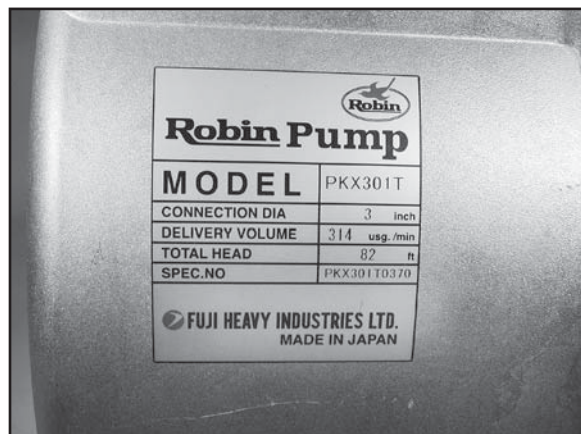

Always refer to the pump ID tag when ordering parts for the pump. The engine has a separate ID tag as well. Refer to the engine tag when ordering engine parts.

1. Drain any water from the reservoir by loosening the drain plug. Loosen the 4 knobs that hold the outer pump housing to the back plate of the pump. Use the special wrench provided with pump.
2. Push the 4 knobs to the side and remove the outer pump housing from the pump back plate.
3. Inspect the volute and outer case for cracks and bent castings. Also inspect wear plate any uneven wear marks. For removal of volute and wear plate from outer pump housing see steps 34 to 48 .
4. Remove plug on back plate housing for access to impeller. Use a soft rod such as aluminum or brass, and a hammer to loosen the impeller. Hit counter-clockwise until loose.

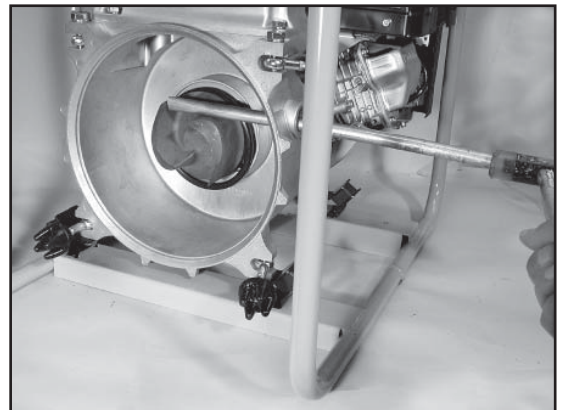
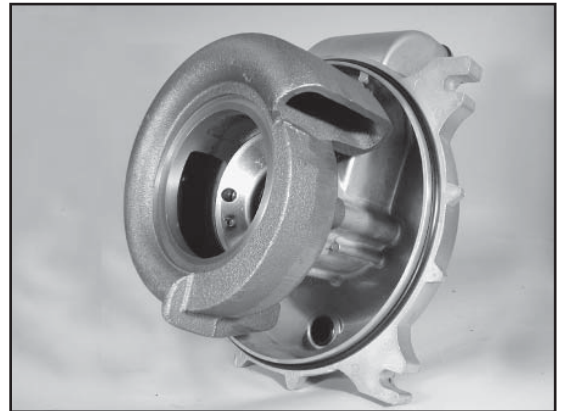
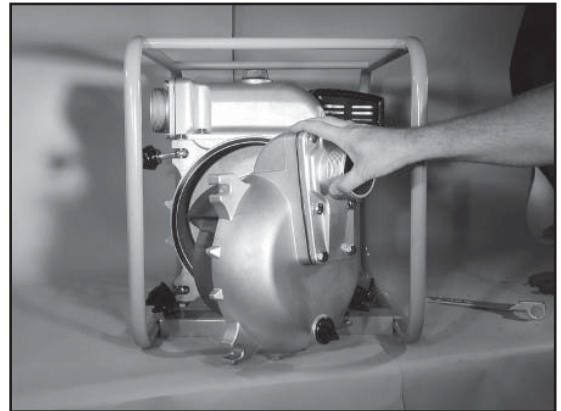
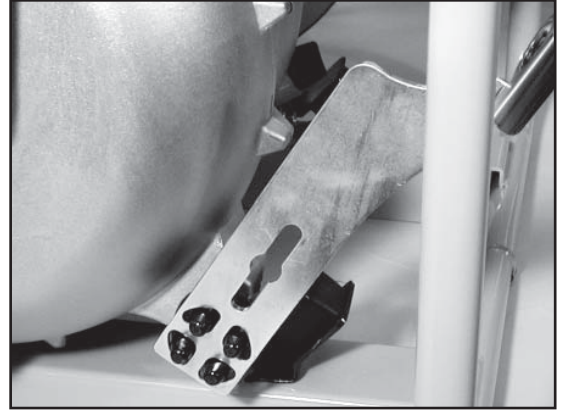

5. Turn the impeller counter-clockwise by hand until free from crankshaft. Be prepared to catch impeller when freed from crankshaft. (Its heavy)



6. Inspect the impeller for cracks and bent blades.

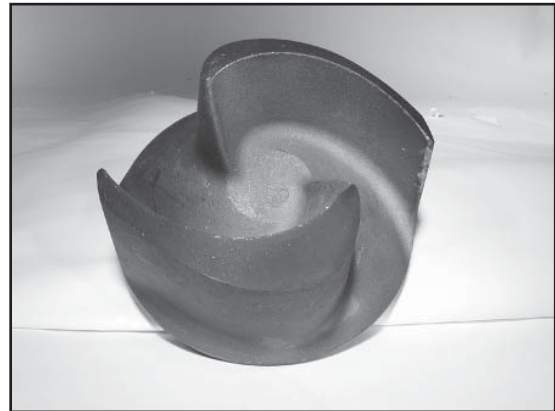

7. Count the number of shim(s) that are located on the crankshaft. Remove slowly and make sure to replace with the same number when reassembling.



8. It is possible that the shim(s) get stuck in the impeller. Use a screwdriver to pry out and inspect. The shim(s) should not be bent or distorted in any way. Replace with new in needed.



9. Turn the impeller over and remove the rotating part of the mechanical seal with a small screwdriver. Pry on the bottom side and lift upward until removed from impeller.
10. There is a wrong side to the rotating seal. The white or colored marks will face inward (or towards the inlet nozzle side of the pump).
11. Sometimes it helps to put a little dish washing soap on shaft to help remove seal. This prevents the sealing lip from possibly tearing when removing.
12. Using two screwdrivers, remove the seal by prying side to side until it is free. It may become necessary to remove pump back plate to remove seal. If this becomes the case then follow the directions in the following steps.

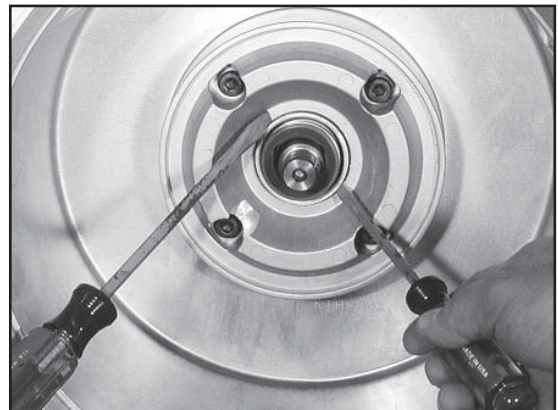
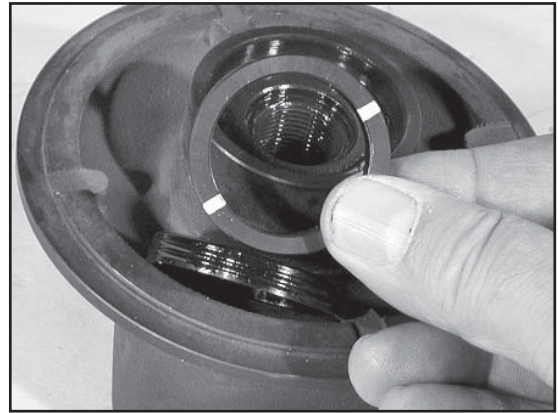
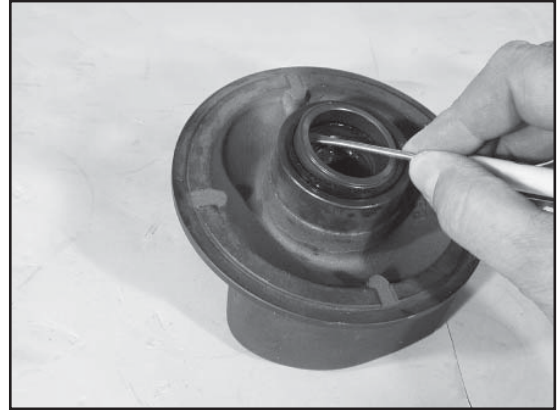

13. Pull the seal off the crankshaft and inspect for cracks, burn marks and overall condition.

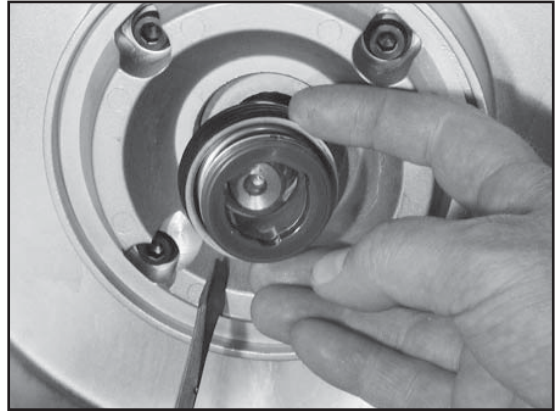

14. This is what a new seal will look like when taken out of box. Compare it to the seal removed.

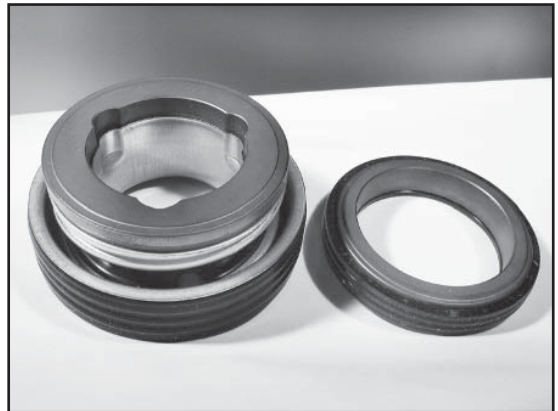

15. Should it become necessary to remove the pump back plate then loosen and remove the four bolts that hold it to the engine. These are special bolts with special washers. Make sure to replace with same part numbers if needed.

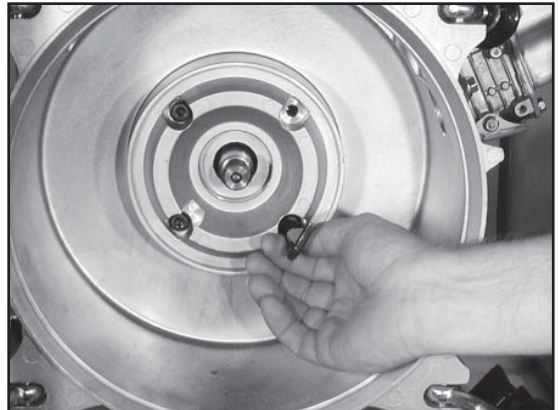

16. Loosen the two bolts that hold back plate to the frame and prepare to tilt the engine back slightly for removal of back plate housing.

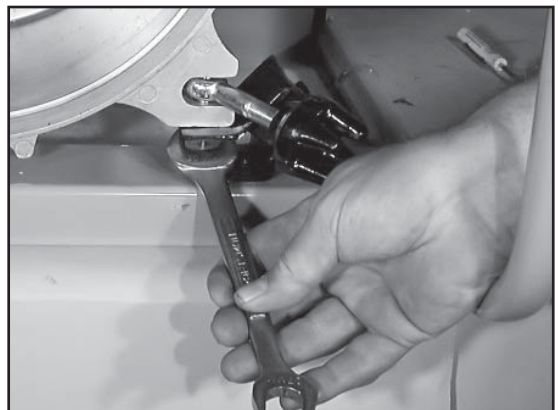

17. Lift the engine and back plate high enough to clear the bolts from the frame mounts.

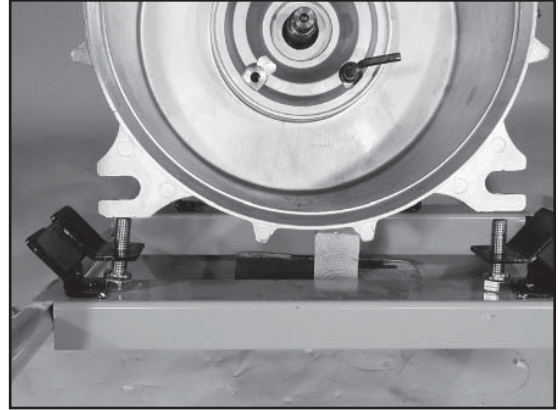

18. Pull the back plate housing from the engine. It may be necessary to tap of the back plate slightly with a rubber mallet.

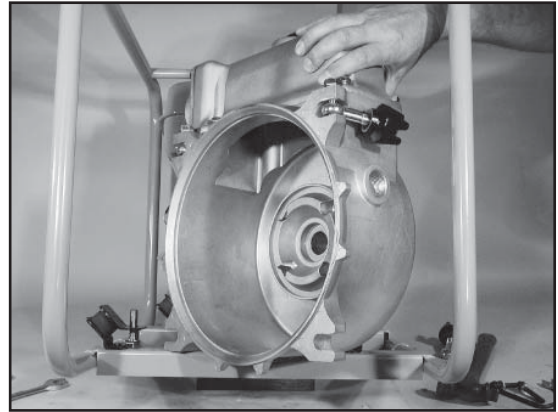

19. Should it become necessary to remove the engine for service, then remove the two bolts that hold it to the engine vibration mounts.

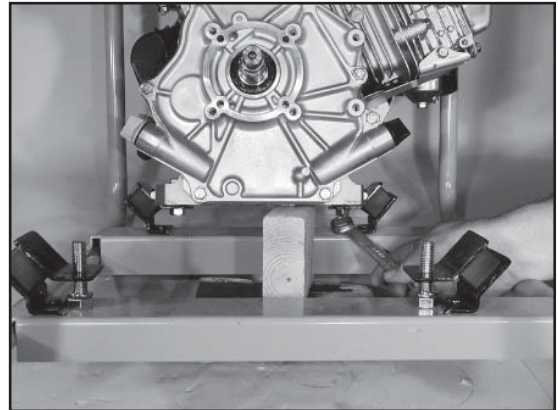

20. When replacing back plate on engine not the weep hole on the backside of pump back plate housing. The weep hole must not be blocked with dirt or other obstruction. This weep hole prevents water from entering engine should a mechanical seal fail will pump-ing water.

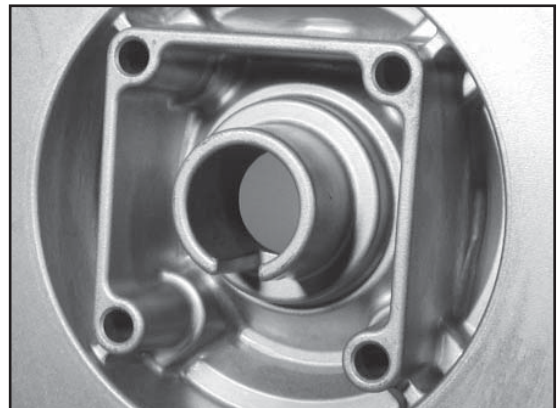

21. Replace back plate housing and hold in position.

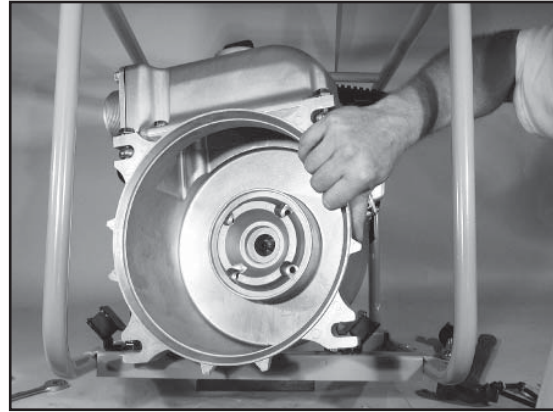

22. Loosely start one bolt to hold in position.

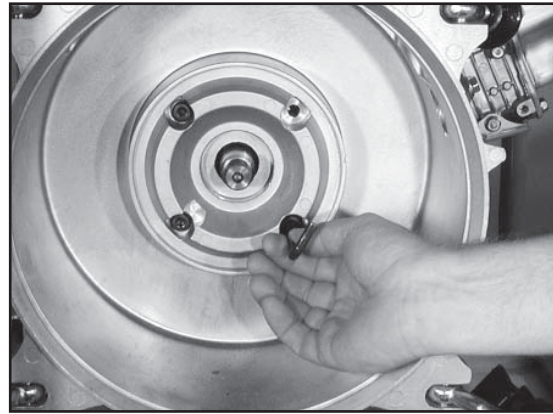

23. Apply a light or medium duty thread locker to the bolts. This would be a service replaceable type of thread locker. Permatex® purple or blue brand.

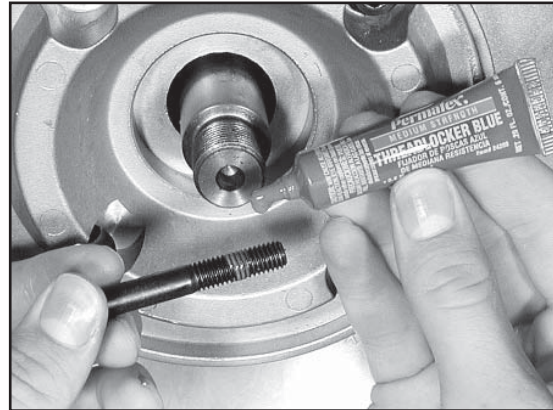

24. Torque back plate bolts to a specified value of 13 to 15 ft. lbs.

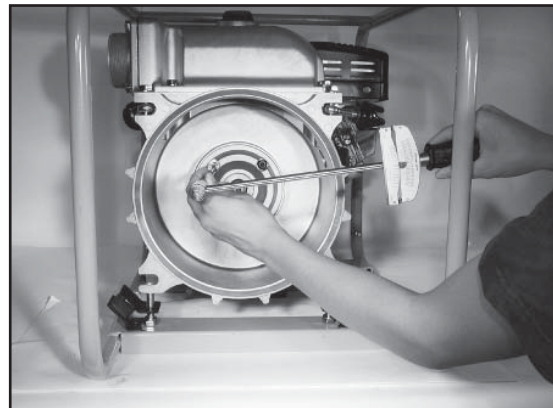

25. After the back plate has been tightened, replace the two bolts that hold the pump housing to the frame.

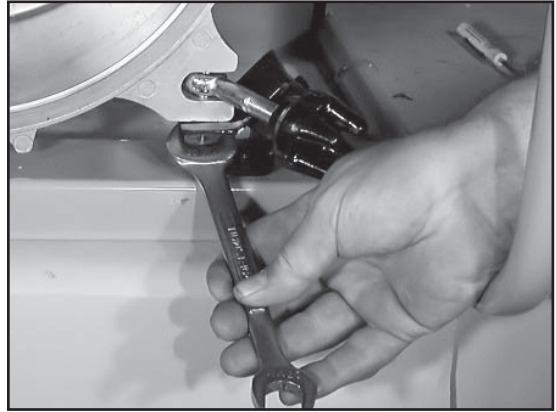

26 When replacing the mechanical seal. Putting some liquid detergent on the seal and crankshaft will ease installation.

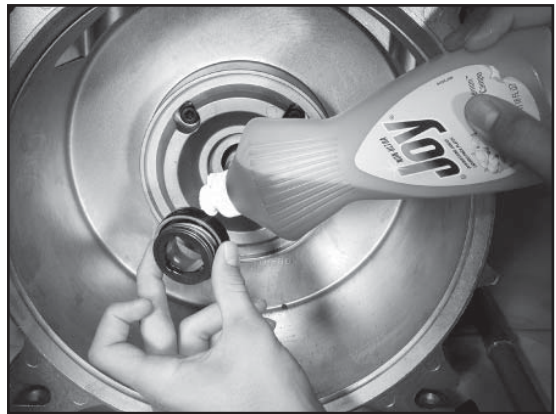

27. Push the seal into place. Using two thumbs will also make it easier. If the pump back plate was removed it will be easier to install the seal before mounting the back plate to the engine.

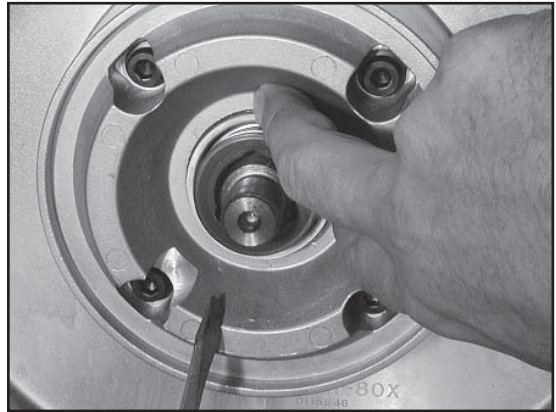

28. Replace the correct amount of shim(s). As noted earlier it will be necessary to replace with the same amount that was taken off.



29. Before placing the rotating seal into the impeller it will help by putting some liquid detergent of the seal. This will ease in installation.

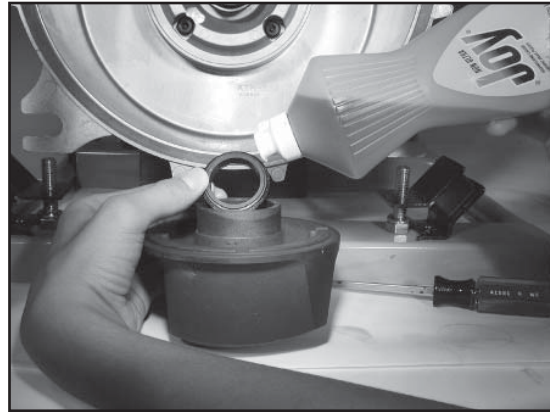

30. Install the seal into the backside of the impeller making sure that the outer seal is not kinked and placed on straight.



31. This is a good time to check the condition of the volute to back plate housing O-ring. Check for cracks, nicks or tears.



32. Turn the impeller on by hand in a clockwise position until tight.



33. To insure the impeller is tight. Hit on one of the blades in a clockwise position till good resistance is felt.

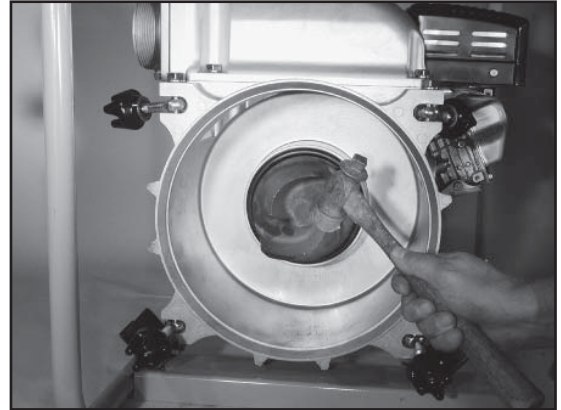

34. Should it become necessary to remove the volute from front pump housing or replace the wear plate, follow the next steps in removing and replacing. Loosen the 3 bolts that hold the volute to the front pump housing. These are Allen head bolts.

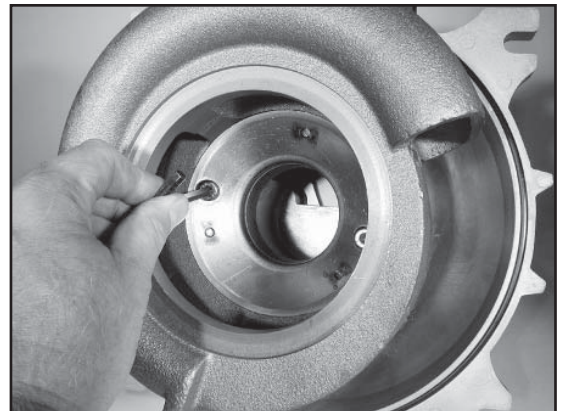

35. After the bolts have been removed, tap with a rubber mallet to free the volute from the housing.

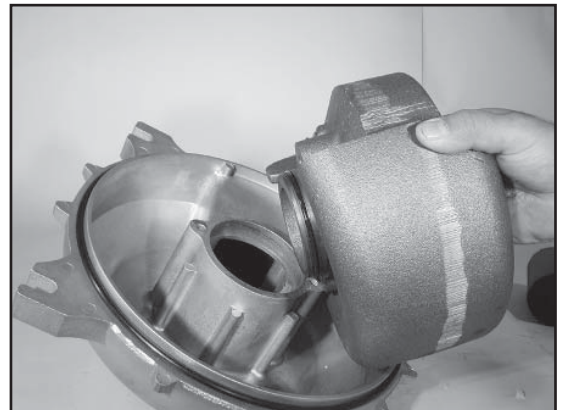

36. Carefully remove the volute from the housing by pulling up.

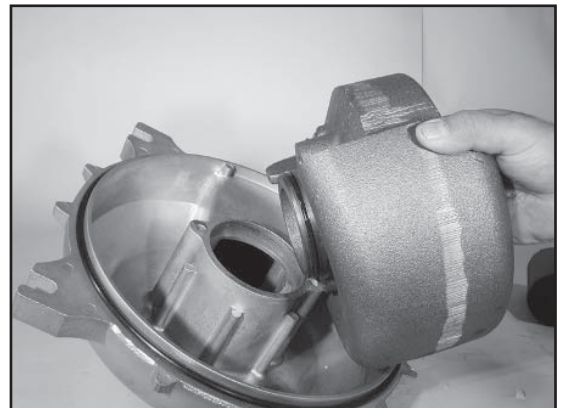

37. This is good time to check the O-ring that seals the volute to the from pump housing. Check for nicks, cracks, and tearing. Replace if necessary.



38. If the wear plate needs to be removed , loosen and remove the three bolts that hold the wear plate to the volute housing.



39. Remove the wear plate and inspect its condition. The surface should be even and not have gouges or uneven wear.

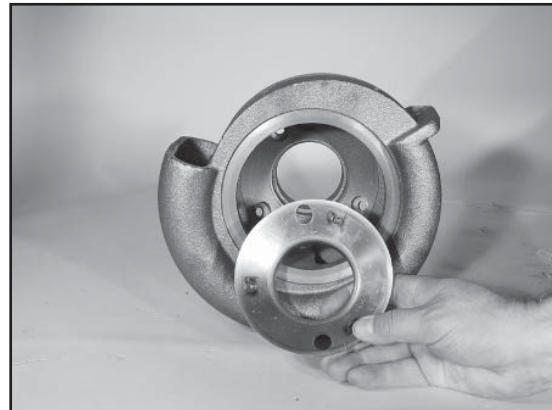

40. This is also a good time to check the condition of the outer pump housing O-ring. Check for nicks, tears and gouging.

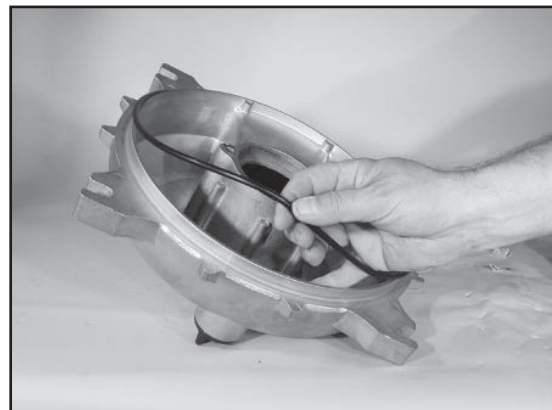

41. This is what a new wear plate will look like. Compare it to the one that was taken out.



42. Install the wear plate in the reverse order that it was taken out.



43. Apply a light or medium duty thread locker to the wear plate bolts before tightening. This should be a service replaceable thread locker as mentioned earlier.

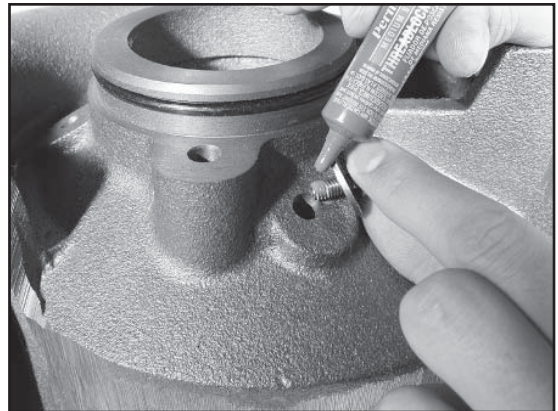

44. Tighten the three bolts that hold the wear plate to the volute.



45. Position the volute back onto the front pump housing. Note position when installing, as it is important which way volute discharge faces. See step 3 for the correct volute position as is installed on front pump housing.



46. Apply thread lock compound to the bolts before installing. Using Permatex® brand such as the blue or purple is recommended. These models are service replaceable.

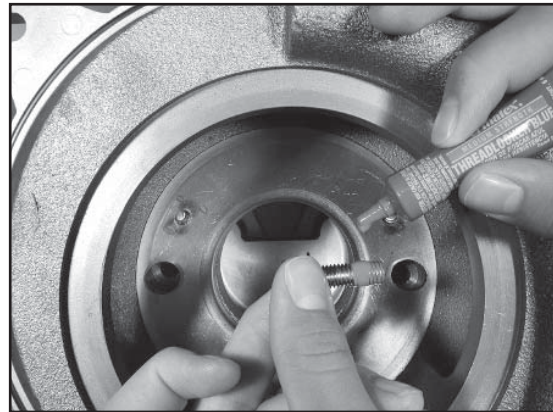

47. Torque to bolts to the specified value of 12 to 15 ft. lbs.

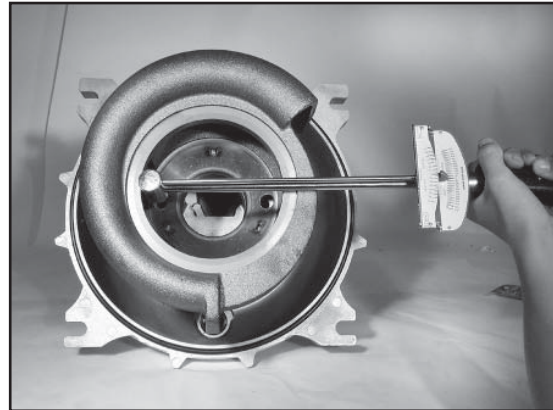

48. The volute and front pump housing are now ready to be installed onto pump back plate.

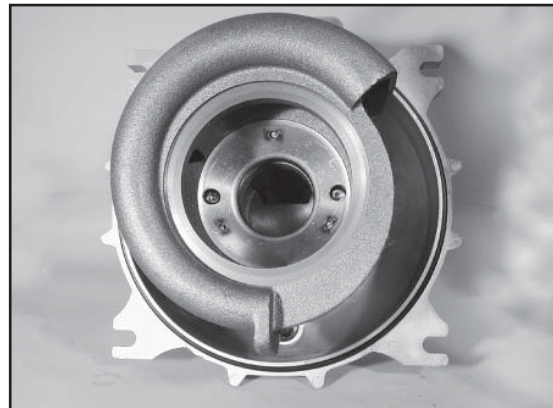

49. Install on back plate and loosely tighten the four knobs making sure the O-ring is seated correctly.

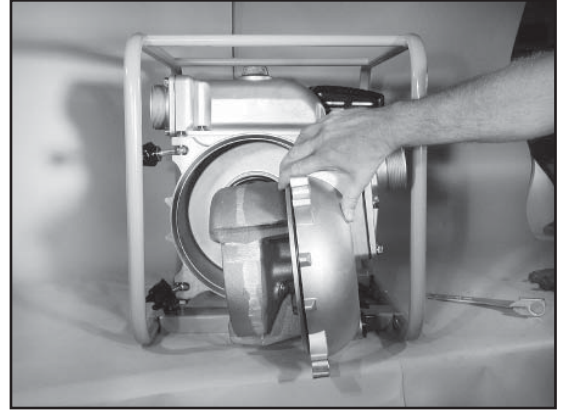

50. Tighten the four knobs with the special tool that is provided with the pump. Tighten very snugly.

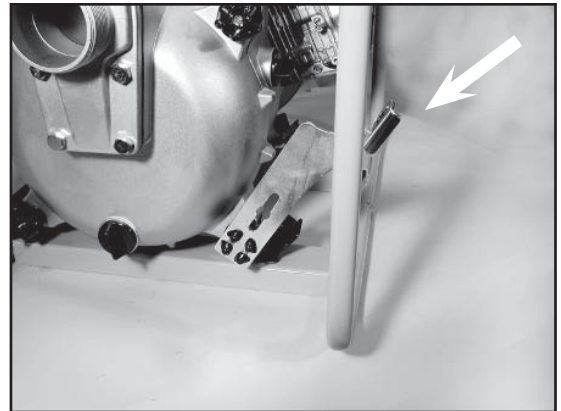

51. Should it become necessary to remove the discharge nozzle then loosen the four bolts that hold it to the pump housing.

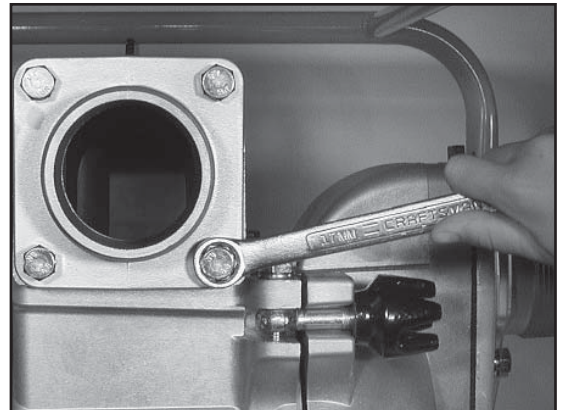

52. Lift the discharge nozzle off the housing watching the position of the gasket. Check for cracks, tears or improper fit.

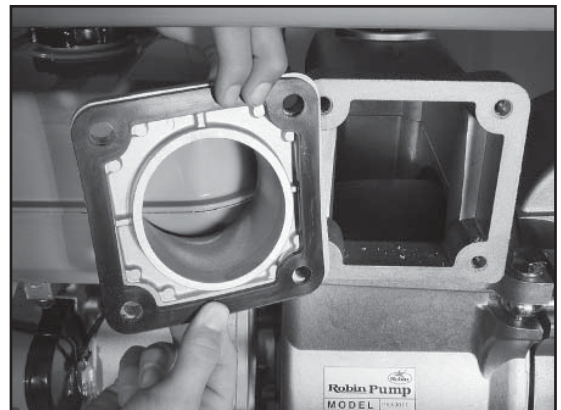

53. The picture shows the correct position of the discharge nozzle. The elongated portion of the discharge nozzle will be on the bottom.

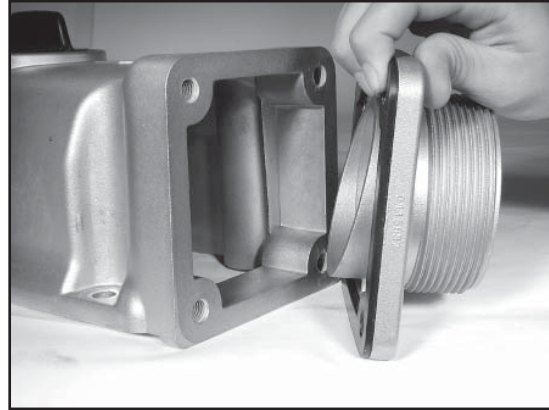

54. Apply a high temperature thread sealant such as: Permatex® High Temperature Thread Sealant to the 4 bolts that hold the discharge nozzle to the pump housing. This will prevent leakage due to vibration, temperature cycling, and extreme pressure. This type of sealant protects against rust, corrosion, and galling of threads. It is service replaceable.

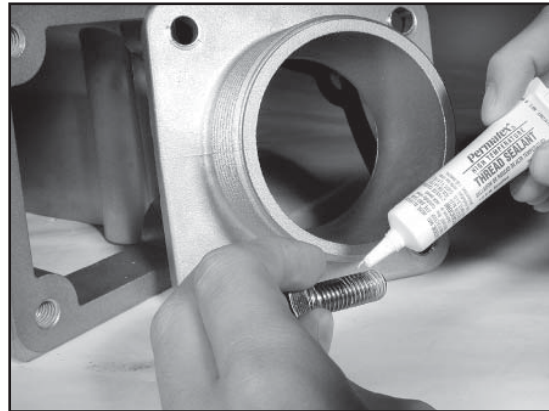

55. After replacing discharge nozzle, loosely and evenly tighten the four bolts that hold it to the pump housing. Torque the bolts to the specified value of:

PKX201T-3 to 4 ft. lbs.

PKX301T-4 to 6 ft lbs.

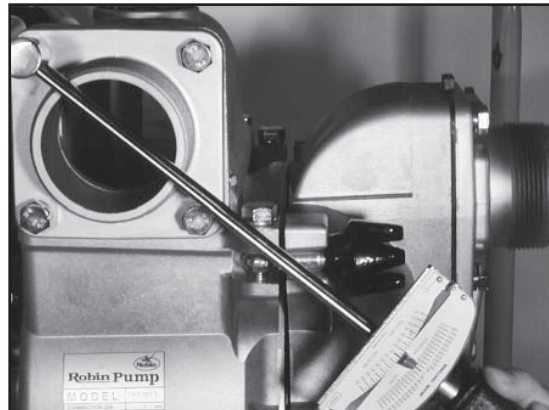

56. Should it become necessary to remove the top pump housing cover, follow the listed procedure. Remove the four bolts that hold the cover in position and lift cover off.

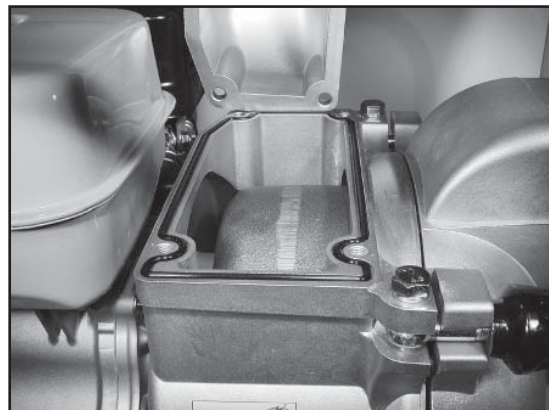

57. Check the gasket for tears, cracks, or twists. Replace if necessary.

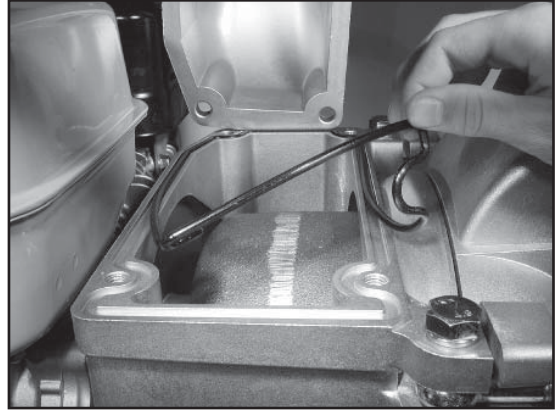

58. Install the four bolts that hold the top cover to the pump housing and torque to specified value of 16 to 20 ft. lbs.

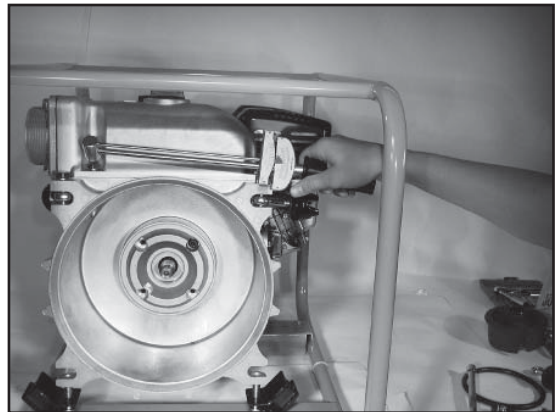

59. Should it become necessary to remove the intake nozzle for service then loosen the four bolts that hold it to the pump housing.

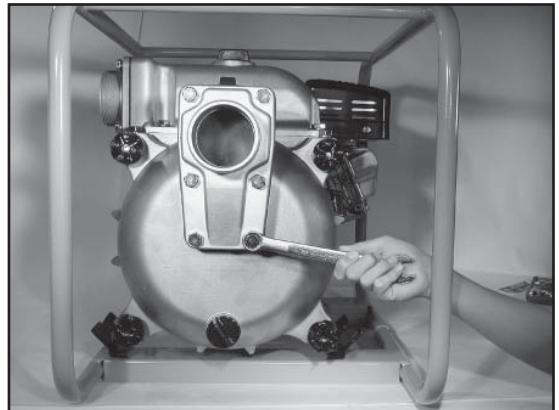

60. Lift the intake nozzle away from the pump housing noting the position of the gasket.

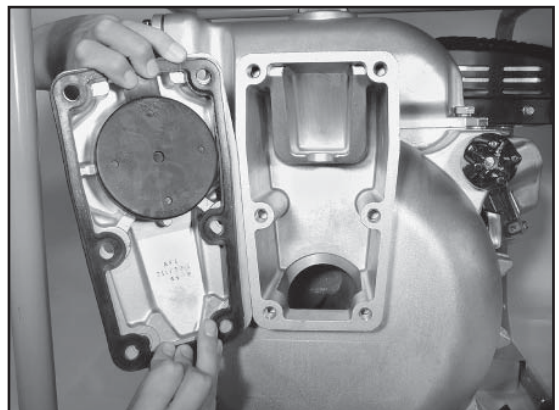

61. The picture show the correct way to install the intake nozzle gasket.

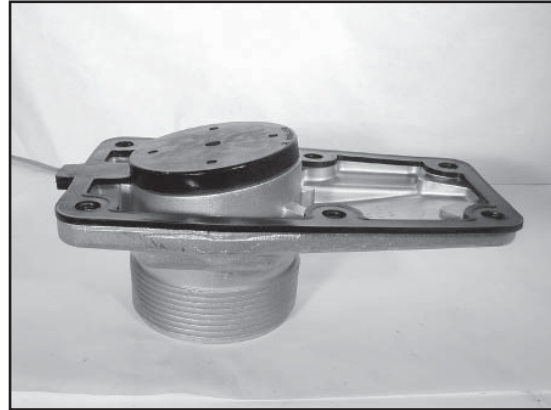

62. Apply a thread sealant the the six cover bolts as in step 54. After lightly tightening the six bolts that hold the intake nozzle to the pump housing, torque to the specified value of 4 to 6 ft. lbs.

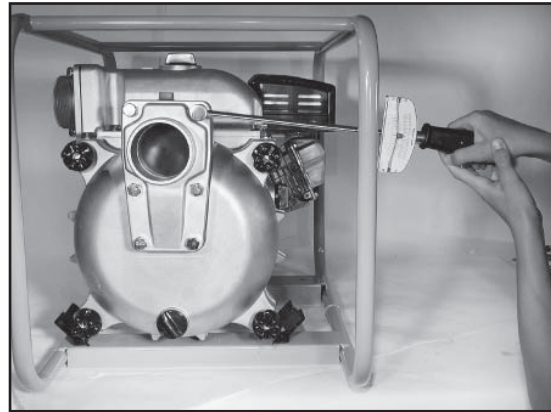

63. Before running check the oil and pull the engine over with the recoil rope to make sure nothing is binding in the pump.

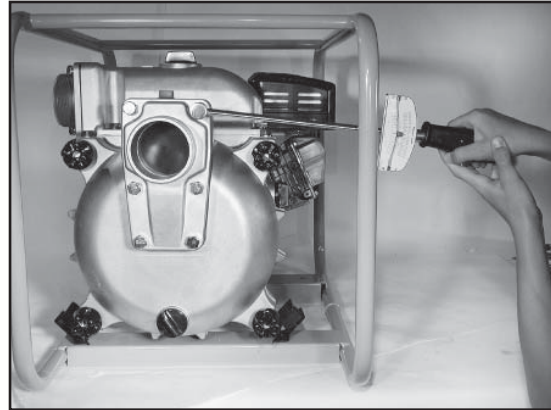

64. Fill the with prime water, start the engine. After warm up run engine at full throttle and check the vacuum with the vacuum tester to make sure no leaks have developed. A vacuum of 20 to 25 lbs at sea level should be read. This reading should be obtained within 5 seconds.

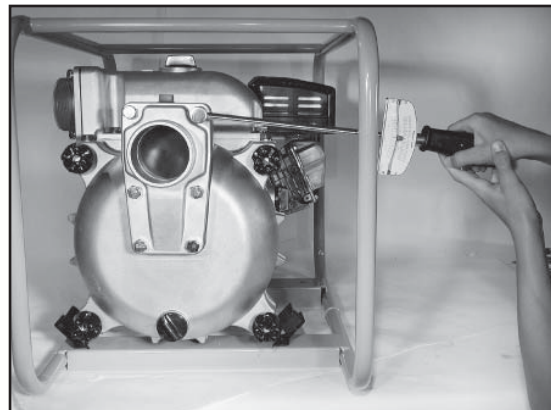

PKX201ST & PKX301ST

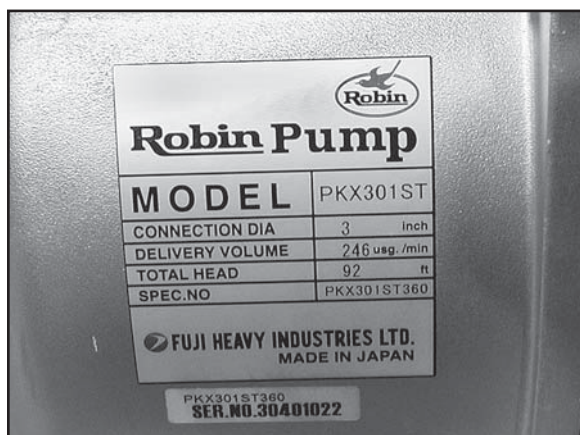
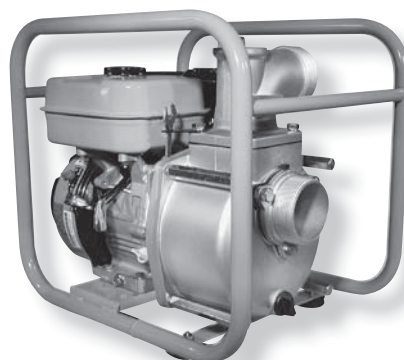
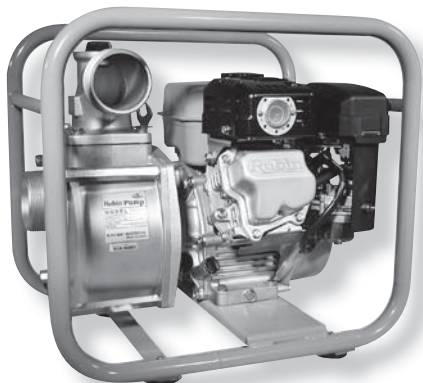

Always refer to the pump ID tag when ordering parts for the pump. The engine has a separate ID tag as well. Refer to the engine tag when ordering engine parts.

1. Drain the water from the reservoir and remove the 4 bolts that hold the outer casing to the pump back plate.

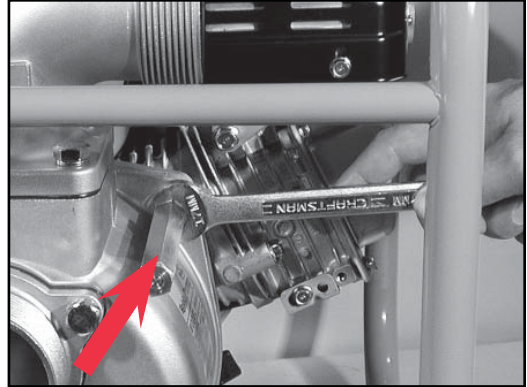

2. Remove outer casing and volute as an assembly. Keep tilted backwards so not to allow the volute to fall out.

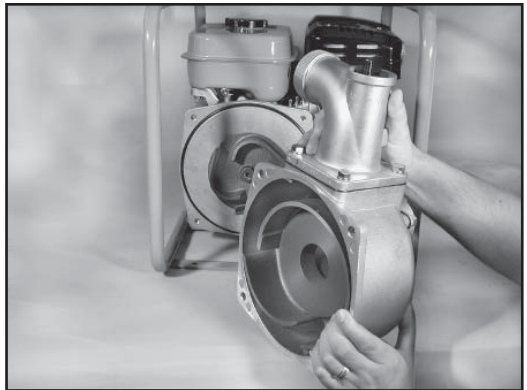

3. Note the slot that is cast into the volute. This must align with the notch cast into the outer casing when re-assembling.

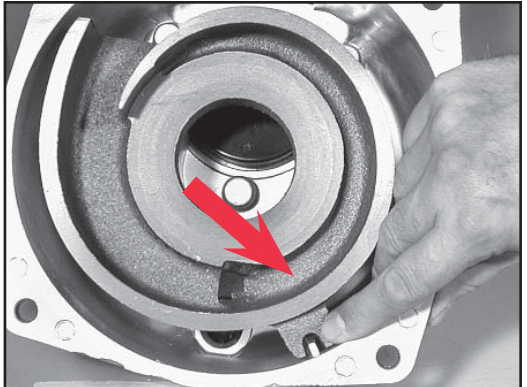

4. Tip the outer casing on its back and pull the volute from the outer casing. If the volute seems to be stuck, (due to the O-ring sticking) then use two hands while holding the outer casing with another person or vise.



5. Inspect the volute for damage. Check for cracks or bent castings.

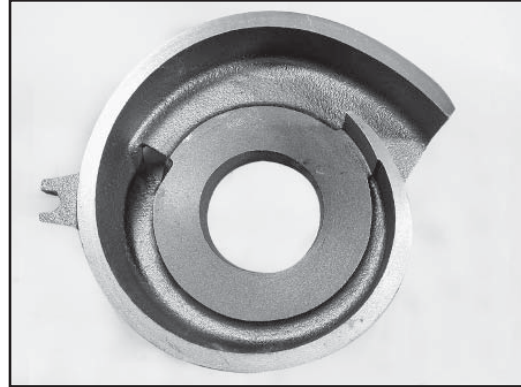

6. Check condition of O-ring on volute. Check for nicks, cracks and gauges. Defective O-rings will cause poor priming and loss of pump performance.



7. Remove impeller with rubber mallet. Hit one of the blades in the counter-clockwise position. It is best to not block the engine for this procedure. Only use a flywheel strap when it does become necessary.



8. Slowly turn the impeller off the crankshaft. Watch that the impeller does not drop off quickly when reaching the end of the threads. Use two hands if necessary. Watch for loose parts such as the shims.

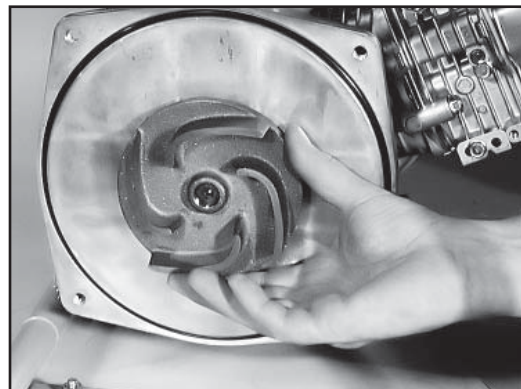

9. Inspect the impeller for defects.



10. Inspect the rotating part of the seal for cracks, chips and worn face.

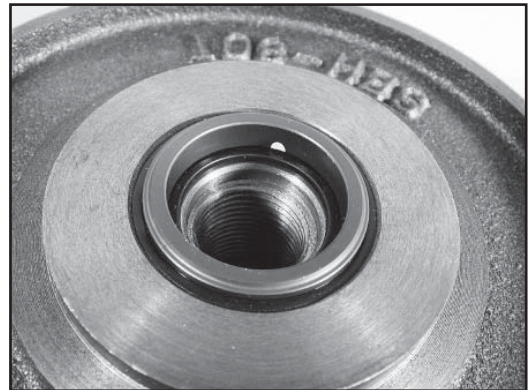

11. It many happen that the shim(s) get stuck inside the impeller. When this condition occurs, carefully pry the shim(s) out with a small screwdriver. If the shims(s) get bent or are flattened beyond use, replace with new one(s).



12. Place a small screwdriver under the seal and pry outward. Placing some liquid (water or detergent) on the seal might help in removing it if it appears to stick to the metal.

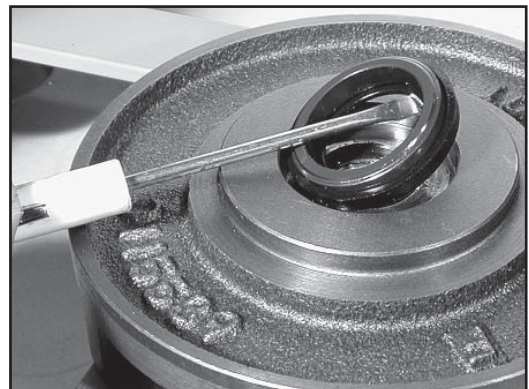

13. The seal has two sides. Make sure that you do not install this side towards the stationary seal in the back plate. The colored bars must face the impeller.

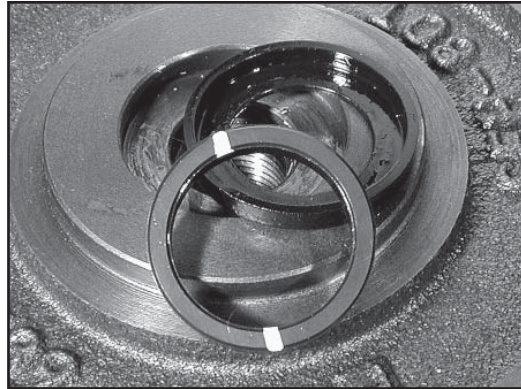

14. Remove the shim(s) from the crankshaft. Count the number that is used and replace with the same amount. Should the impeller or volute be replaced as new parts, it will become necessary to re-shim according to the re-shimming guide located in the service manual.

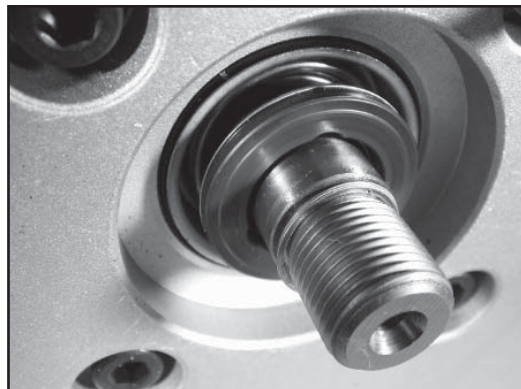

15. Placing some liquid (water and liquid detergent) on the crankshaft. This will create slippery surfaces to help in removal.

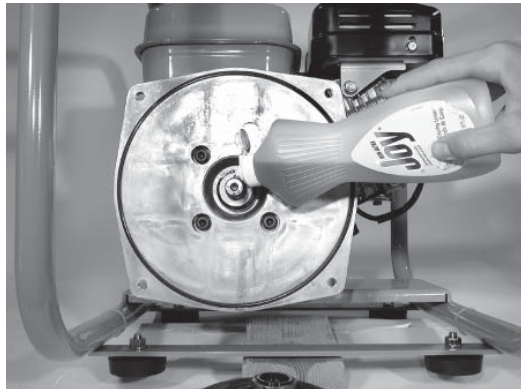

16. Using two screwdrivers pry the seal outward evenly. Should this prove to not work it will become necessary to remove the backing plate and push out from the backside. See step 22 for explanation.

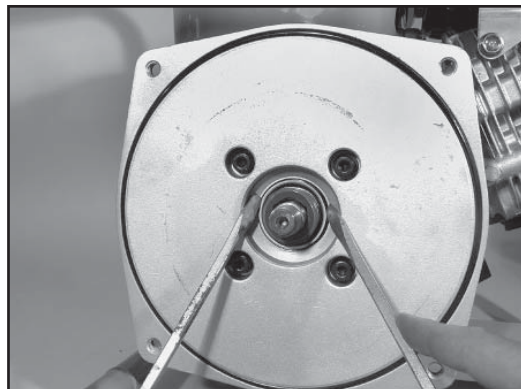

17. Slide the seal over the crankshaft.

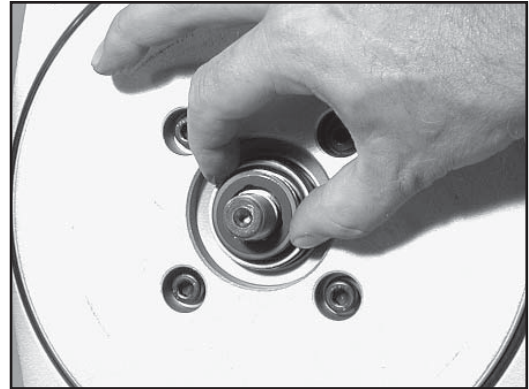

18. After removing from the back plate, inspect the surfaces closely. No cracks, chips or uneven wear should show. If pump was run without water, the surface of the seals will have a worn and burnt appearance.



19. This is a good time to check the condition for the O-ring that seals the outer pump housing to the back plate. Check for nicks, cracks, and replace with new part if necessary.

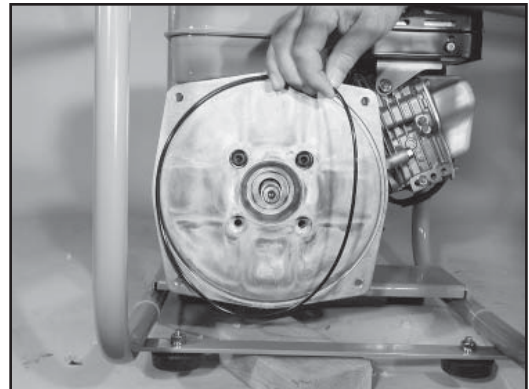

20. If it becomes necessary to remove the back plate for servicing the engine, use an allen wrench to remove the 4 bolts that attach it to the engine.

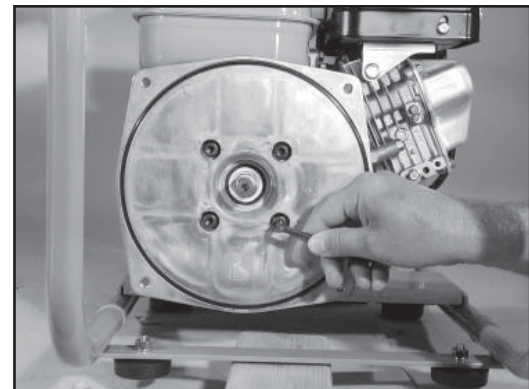

21. Lift the back plate out of the way and inspect for damage. This is also the way to remove the seal if it is stuck in backplate.

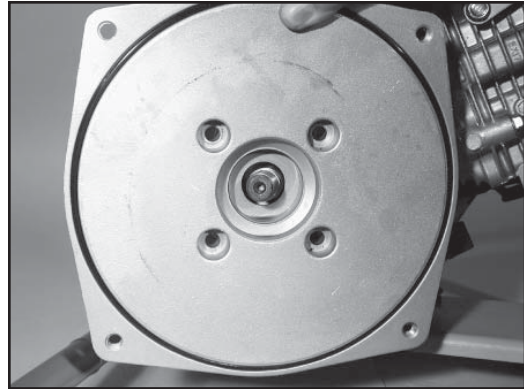

22. If the seal still does not come out, it may become necessary to push on the back of the seal with a screwdriver to remove from its position.



23. Behind the pump backplate is a smaller engine adapter plate that will need to be removed if engine work is necessary. It will pop off with a soft rubber mallet if stuck on.

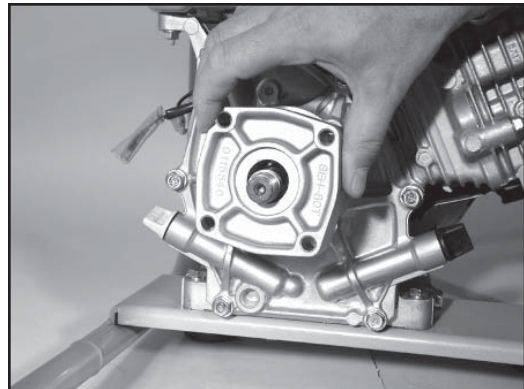

24. The engine is held on with four bolts. Loosen the four bolts and remove from frame if engine work is needed.

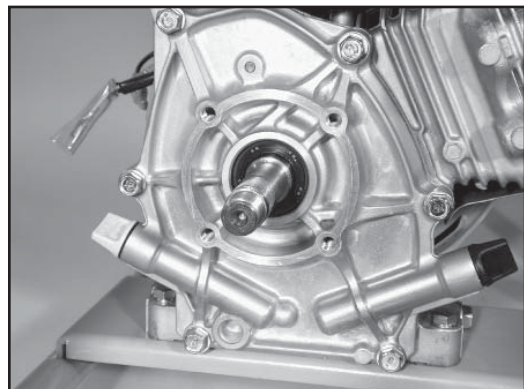

25. When reinstalling the smaller adapter plate, make sure the weep hole faces downward. The weep hole is to prevent water from entering the engine should the seal wear out.

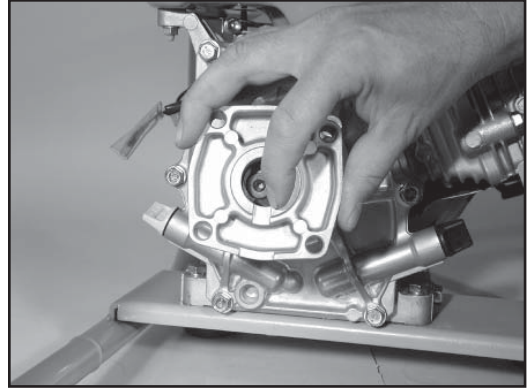

26. The next step after placing the small adapter plate on the engine is to mount the large adapter plate. Note: the weep hole position as well, keeping it pointing downward. Use one bolt to hold on temporarily.

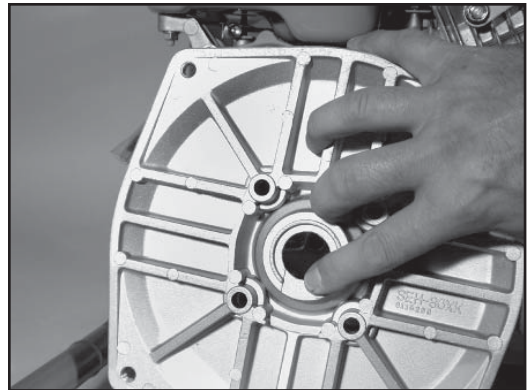

27. Place a small amount of thread locking compound on the tip of the mounting bolts when reinstalling. Note: make sure to replace with special supplied bolts and washer attached. These are special bolts that are used for sealing pump to engine.

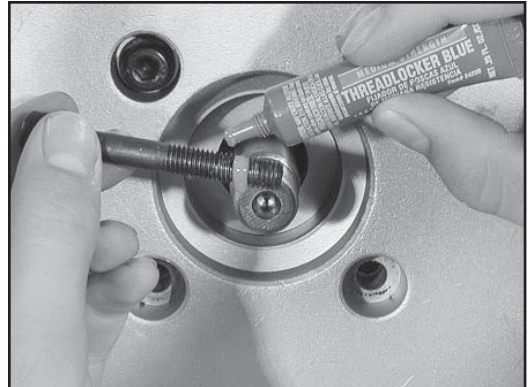

28. Tighten snugly with hex head (allen wrench) watching that the adapter plate align correctly with the back plate.

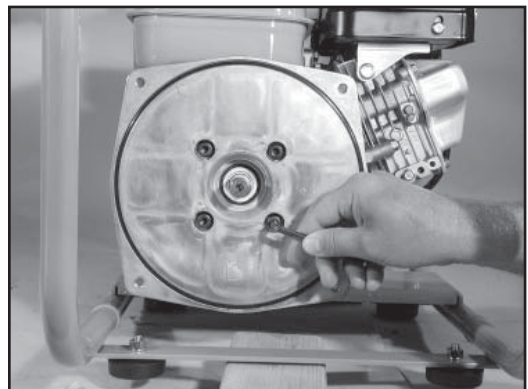

29. Using a torque wrench with a special allen head socket, torque the bolts to a specified value of 12 to 15 ft. lbs.

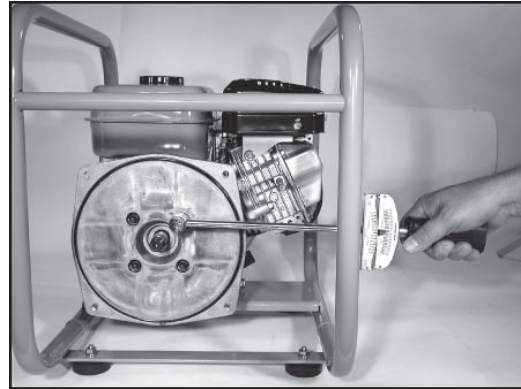

30. Place a small amount of liquid detergent and water on the crankshaft and inner seal. This will make the installation of the seal easier.

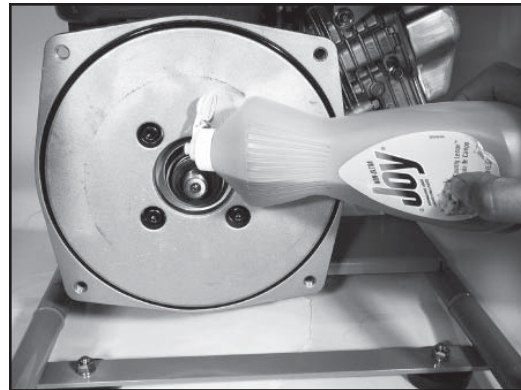

31. Push the seal into the cavity with your two thumbs and seat it snugly into position. It might be easier as noted earlier to position the seal into the backplate when the backplate is removed from engine.

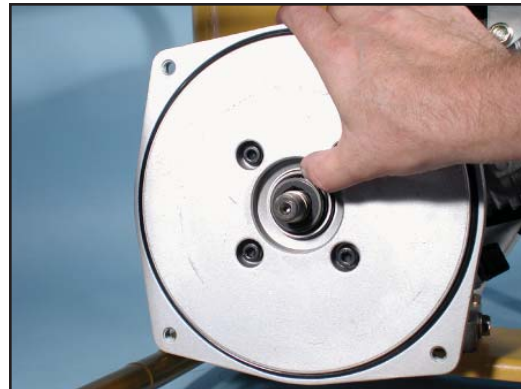

32. Reinstall the shim(s) using the same number as was taken off in previous steps. If new components such as impeller or volute was used, it may become necessary to re-shim with new shims for proper volute to impeller clearance. Check the section on "How to Shim Semi-Trash Pumps" in the Service Manual.

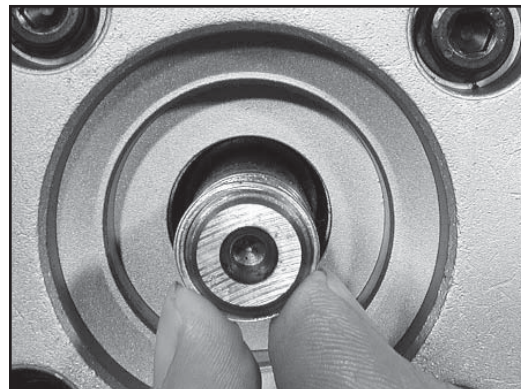

33. Pour a little liquid detergent on the backside of the impeller before trying to install the rotating seal.



34. Push seal into cavity with one or two thumbs making sure the seal is seated correctly.

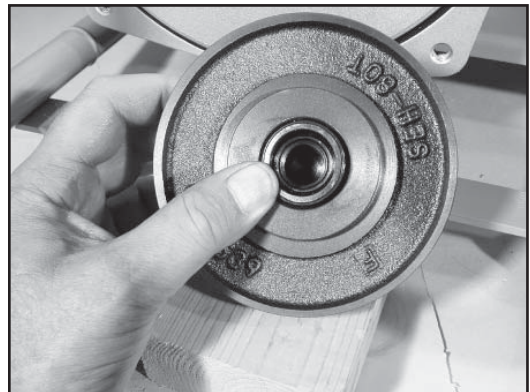

35. Reinstall the impeller and hand tighten on the crank shaft. Make sure it is threaded on all the way. If impeller is not threaded on the full depth, the impeller face could strike against the inside of the volute.

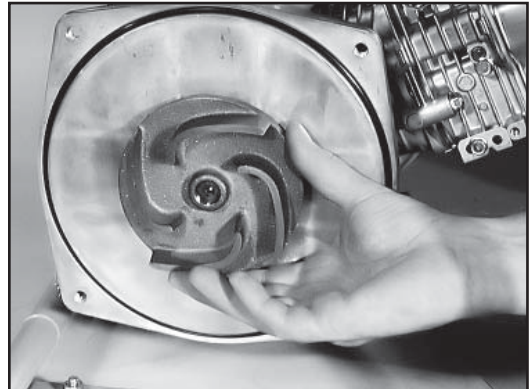

36. To make sure the impeller is installed correctly hold the volute against the backplate and check the clearance with a feeler guage. If the clearance is larger than 0.040 in., then another shim must be added. If there is less than 0.020 in of clearance between the volute and impeller, then it is possible a shim would need to be removed.

Note: make sure impeller is threaded tightly against backing plate.

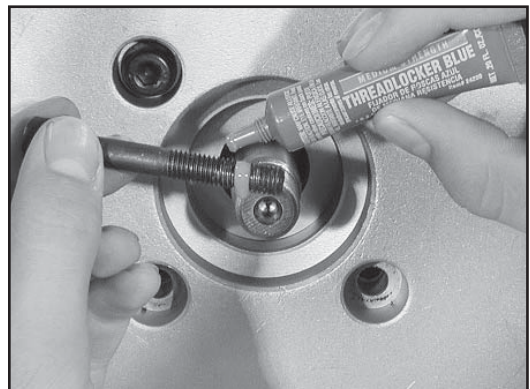

37. Remove the volute and re-tighten the impeller by hitting the blades in a clockwise direction. It should be tight enough that you should not be able to turn it loose by hand.



38. Re-install the volute into the outer case making sure the slot is resting on the casting molded into the outer case.

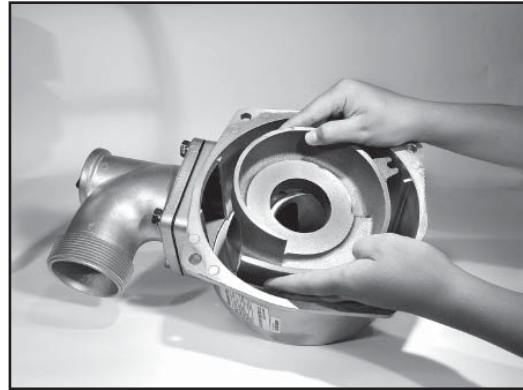

39. It is important that the volute slot matches with the cast in notch in the outer pump housing.

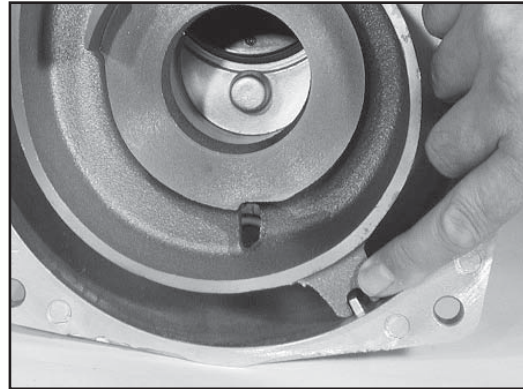

40. Replace the cover and volute onto the pump back-plate. Install the four outer pump case bolts.

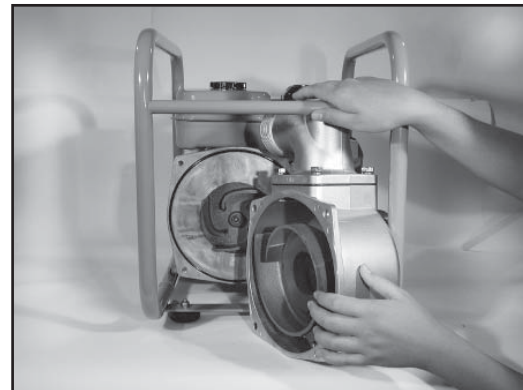

41. Tighten and torque the four bolts to a minimum torque of 200kg/cm.



42. Once the case is torqued down, pull the recoil starter to check that pump and engine turn over freely. If OK, then re-fill with prime water. Next check the engine oil and start the engine. Apply vacuum pressure plate tester per service manual and check for leaks.



43. If it becomes necessary to remove the discharge nozzle, the following procedure is recommended. Loosen and remove the 4 bolts that hold the nozzle housing to the outer casing.



44. Remove the discharge nozzle and inspect the gasket and nozzle for cracks.



45. When replacing the gasket make sure the gasket is flat and not kinked. The gasket does not have a specified side to place on pump housing.

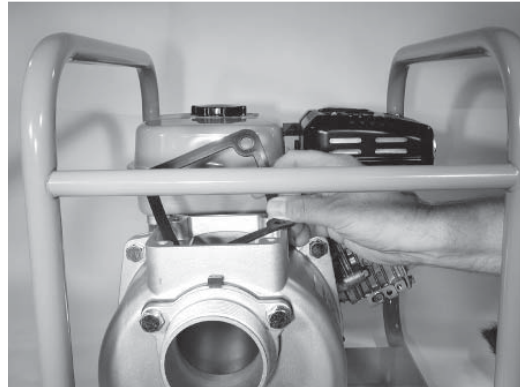

46. Re-install discharge nozzle and torque to specified recommendations.

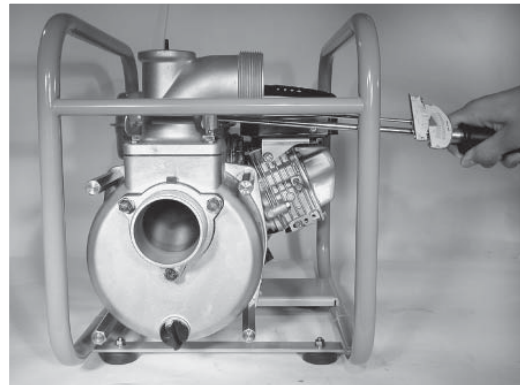

47. If it becomes necessary to remove the inlet nozzle, the following procedures are recommended. Loosen the three bolts that hold the casting to the outer pump housing.

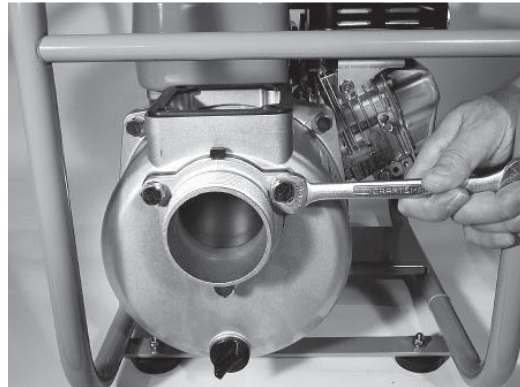

48. Lift the outer cover and gasket from the pump housing. Note position of gasket. Check gasket for cracks, nicks or other areas that might cause a air leak.

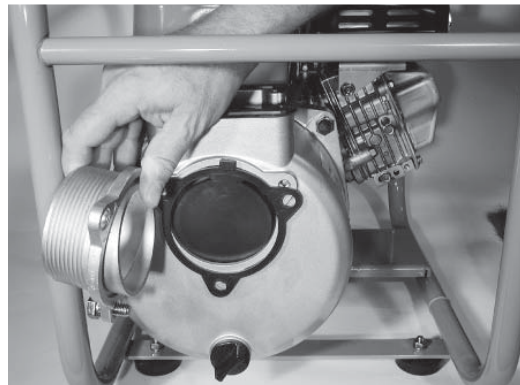

49. There is a correct way, and a wrong to install the inlet gasket. Make sure that the gasket does not have casting marks facing outward.

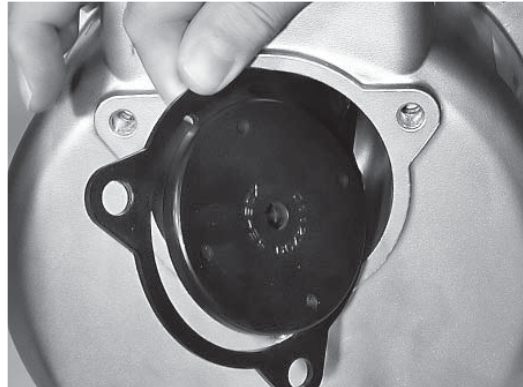

50. This picture shows correct way to install gasket. Make sure gasket is flat against the outer housing when reinstalling cover. Align holes and thread the three bolts into the nozzle and cover.



51. After reinstalling bolts, torque to the specified torque value. Note: the gasket tab that sticks upward showing correct placement of gasket.

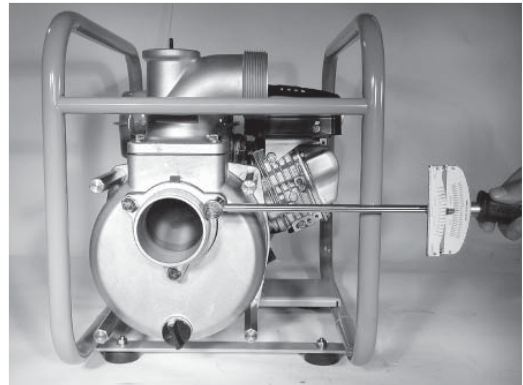

52. Pull the engine over with rope start to make sure there is no binding of pump components. Then fill with gas, oil, and prime water. Place vacuum tester over intake opening and check inches of vacuum. The needle should rise to 20 to 25 inches of vacuum within a few seconds. If not, check for volute to impeller clearance or gasket in pump components that might not be seated correctly.

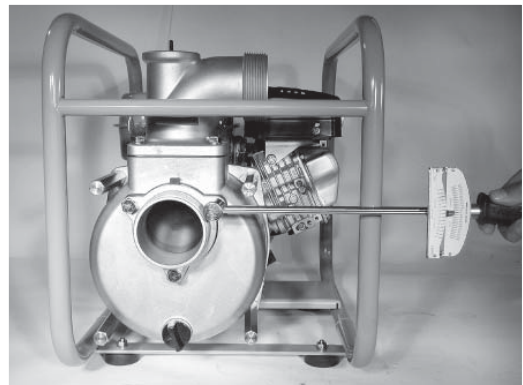

PKX201H

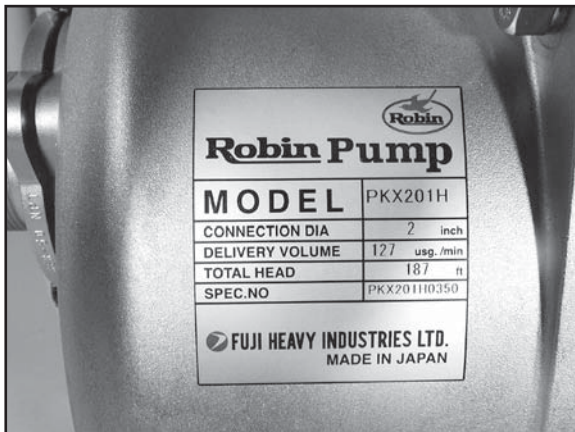
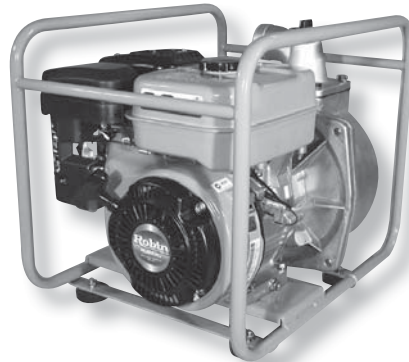
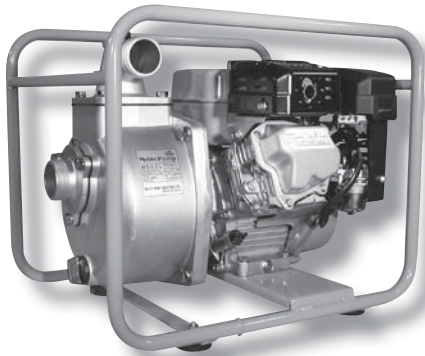

Always refer to the pump ID tag when ordering parts for the pump. The engine has a separate ID tag as well. Refer to the engine tag when ordering engine parts.

1. Drain water from the reservoir and remove the 4 bolts that hold the outer casing to the pump back plate.

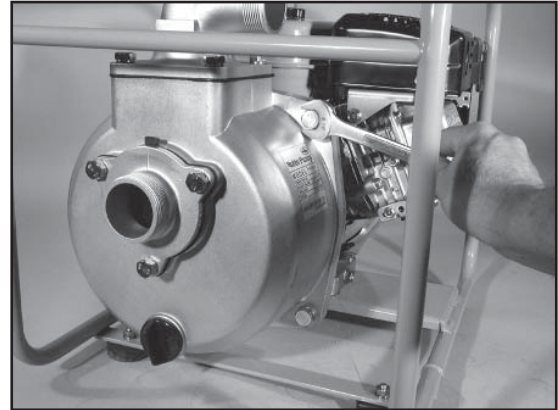

2. Remove outer casing and volute as an assembly. Tip backwards not allowing the volute to drop out of the casing.

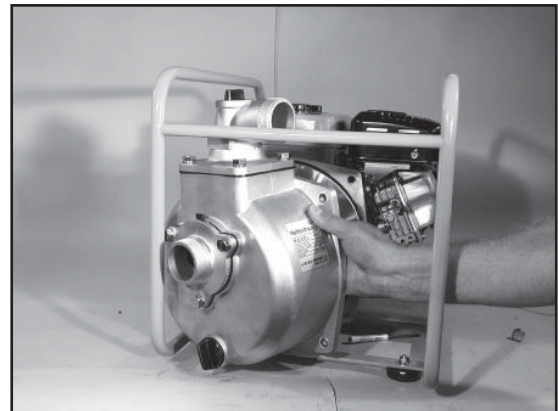

3. Correct volute placement is shown in picture. Discharge chute is pointing upward.

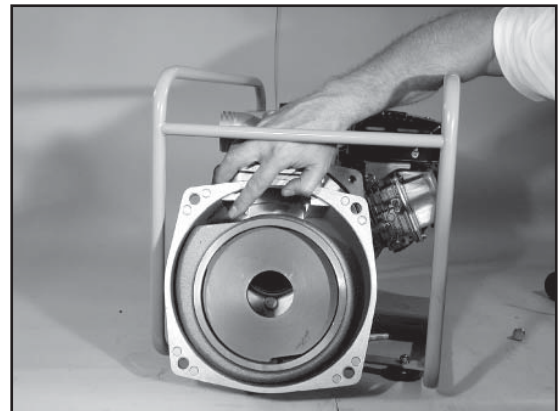

4. Tip the outer casing on its back and pull the volute from the outer casing. If the volute seems to be stuck, (due to the O-ring sticking) then use two hands while holding the outer casing with another person or vise.

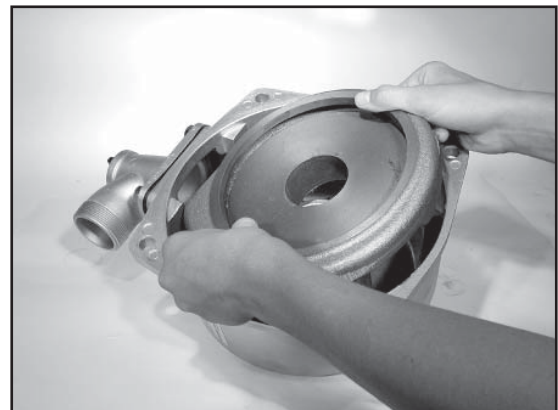

5. Inspect the volute for damage. Check for cracks or bent castings. Note: the locator casting marks in volute. These marks need to be placed between cast in notch in outer pump casing when reinstalling.



6. Check condition of O-ring on volute. Check for nicks, cracks and gauges. Defective O-rings will cause poor priming and loss of pump performance.



7. Remove impeller with rubber mallet. Hit one of the blades in the counter-clockwise position. It is best to not block the engine for this procedure. Only use a flywheel strap when it does become necessary.

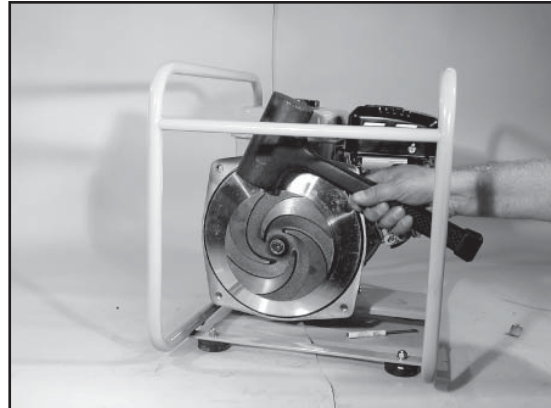

8. Slowly turn the impeller off the crankshaft. Watch that the impeller does not drop off quickly when reaching the end of the threads. Use two hands if necessary. Watch for loose parts such as the shims.

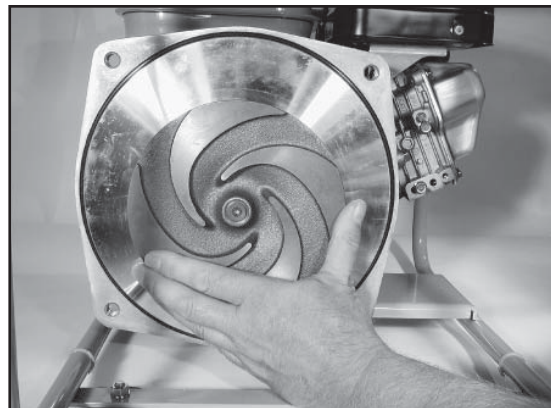

9. Inspect the impeller for defects.

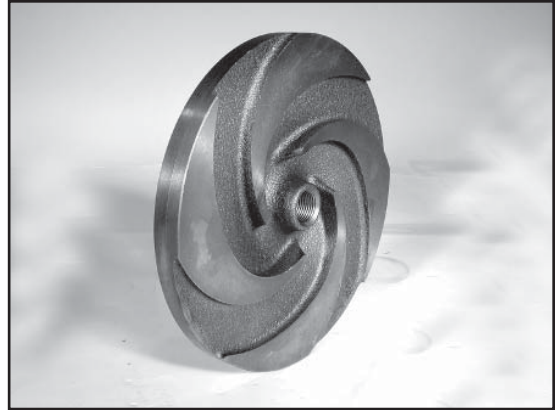

10. Remove the spring from the crankshaft. Note: It can be replaced in either direction.

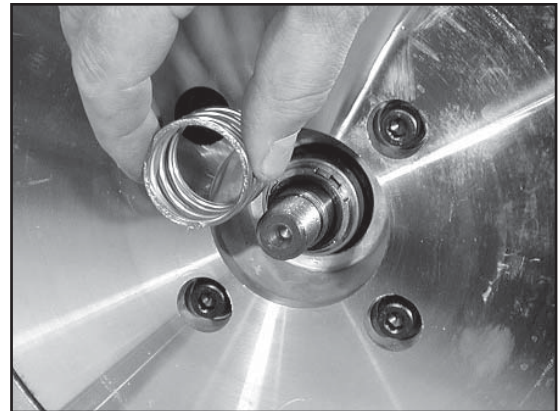

11. Remove the shim(s) from the crankshaft. Count the number that is used and replace with the same amount. Should the impeller or volute be replaced with new, it will become necessary to re-shim according the re-shimming procedure noted later in these instructions.



12. When the shim(s) get stuck inside the impeller. Carefully pry the shim(s) out with a small screwdriver. If shim(s) get bent or are flattened beyond use, re place with new one(s).

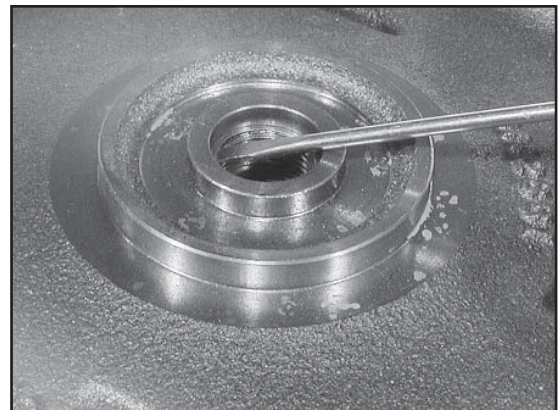

13. This is what the shims will look like if in good condition.

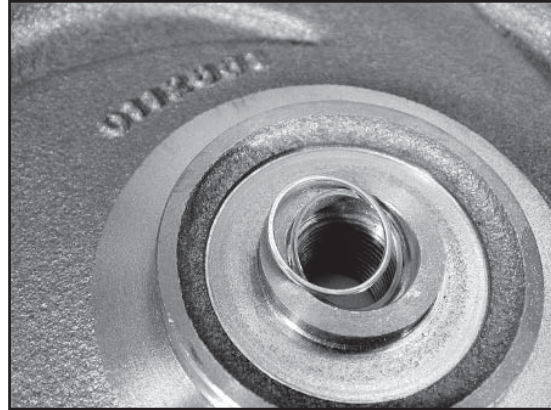

14. Before trying to pull the rotating seal half (carbon side) off the crankshaft, it might become necessary to clean the crankshaft with an emery cloth. Apply liquid detergent to the crankshaft as well as on the seal. This will help prevent the sealing lip from tearing when removed.

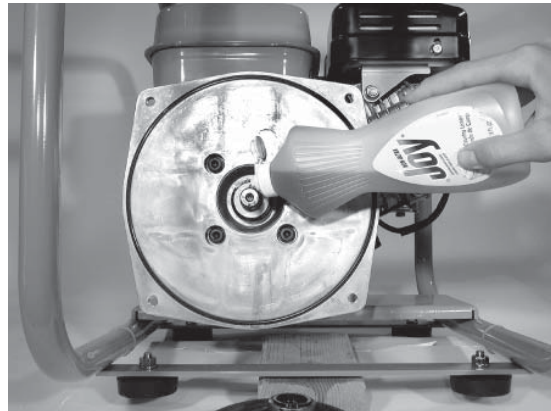

15. Using a pliers, carefully pull the rotating half (carbon side) off the crankshaft. Squeezing to hard will ruin the seal. A better way to remove the seals would be this procedure: loosen the backplate bolts (step 22), and pull the backplate forward. The pulling force of the entire backplate will help remove the seals without bending or distortion.

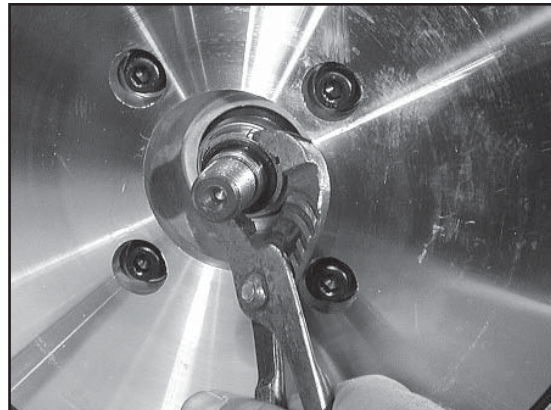

16. After removing the rotating seal, inspect the surfaces closely. No cracks, chips or uneven wear should show. If pump was run without water, the surface of the seals will have a worn and burnt appearance.



17. Use a small screwdriver to pry between the ceramic seal and the black rubber seal that holds it in place.



18. If the seal seems to be stuck, squirt some liquid soap on the seal. This will loosen it from the black outer rubber seal. Using one or two screwdrivers, pry the seal outward. It may become necessary to remove the pump backplate when the seal is stuck. See step 22 for removal of backplate.

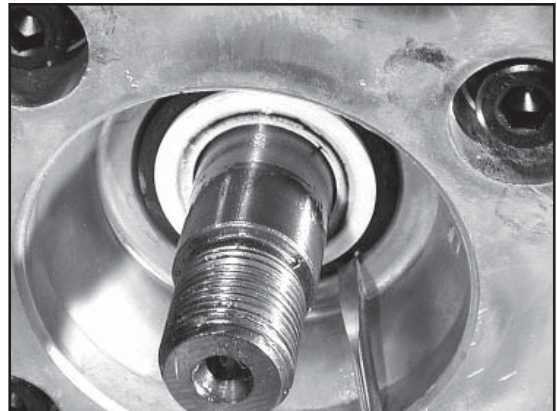

19. This is what the seal will look like when removed.

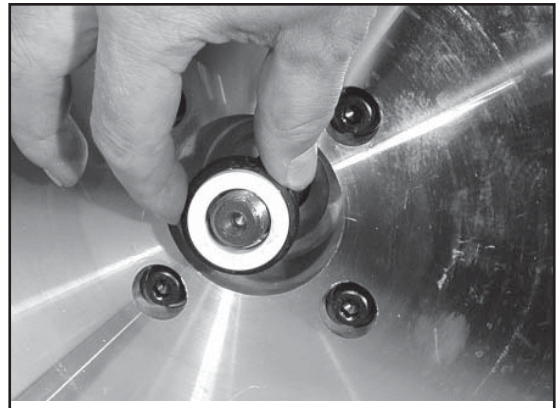

20. Make sure never to use the back side of a seal when re-installing. The back side of the seal will usually have some colored marks indicating it is the wrong way.

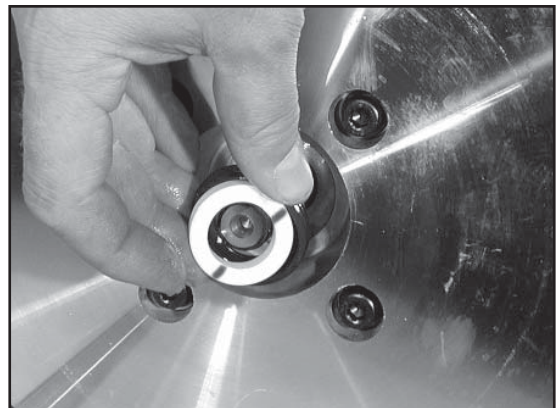

21. This is a good time to check the condition of the O-ring that seals the outer housing to the back plate. Check for nicks, cracks, and replace if necessary with new.

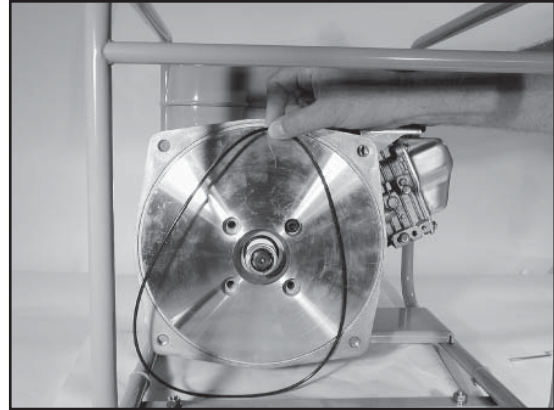

22. If it becomes necessary to remove the back plate for servicing the engine, follow the procedures in steps 22-29. First, use an Allen wrench to remove the 4 bolts that attach it to the engine.

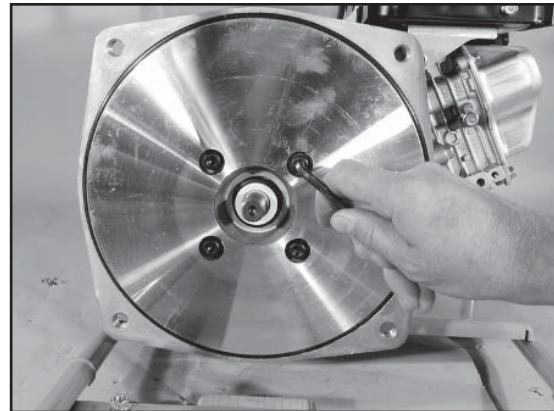

23. Lift the back plate out of the way and inspect for damage.

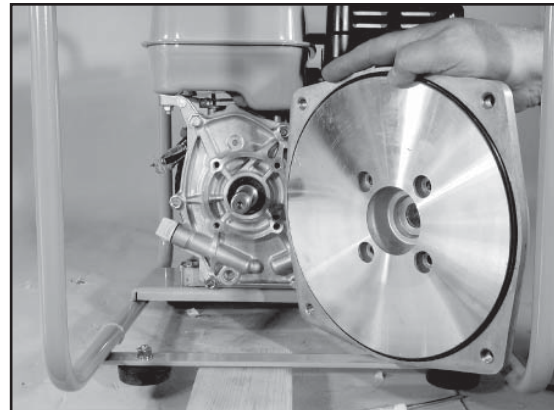

24. If it becomes necessary to remove the engine from the frame, remove the four bolts that hold it to the base plate of the pump frame.

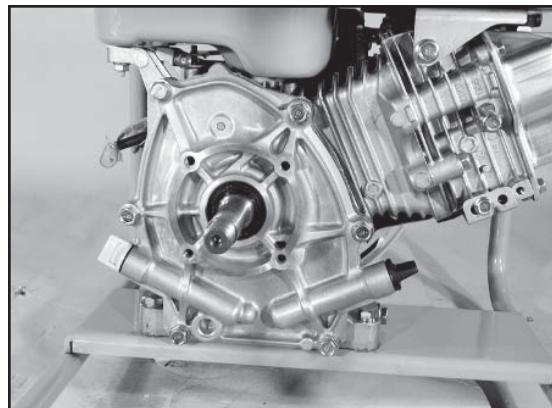

25. When reassembling the back plate to the engine make sure the weep hole is facing towards the bottom of frame. The weep hole is to prevent water from entering engine should a mechanical seal wear out.

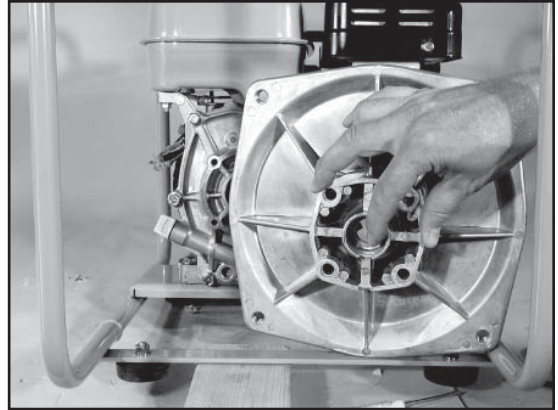

26. Install the pump back plate onto the engine. Install with one bolt to hold into position.

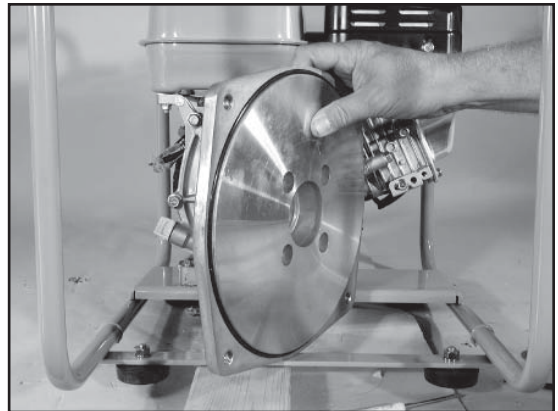

27. Place a small amount of thread lock sealer on the tip of the bolts before reinstallation. Note: only use Allen head bolts and special sealing washers. Washer should fit snug around bolt. Inspect for cracks in the sealing surfaces of the washers. Replace with new if needed. Note: Threadlocker Blue or Purple from Permatex is recommended. It is a light, or medium strength product, and service removable.



28. The four bolts should be tightened snugly by hand. Tighten diagonally to ensure even installation.

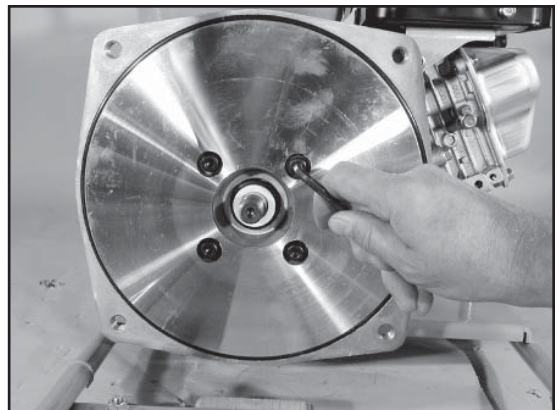

29. Using a torque wrench with a special Allen socket, torque the bolts to a specified value of 12 to 15 ft. lbs.

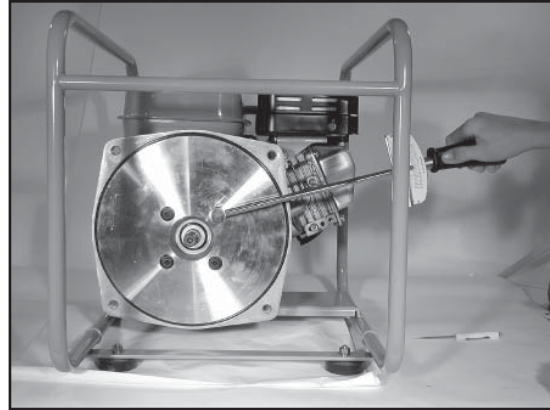

30. Place a small amount of liquid detergent around the seal and rubber holder to ease in installation.

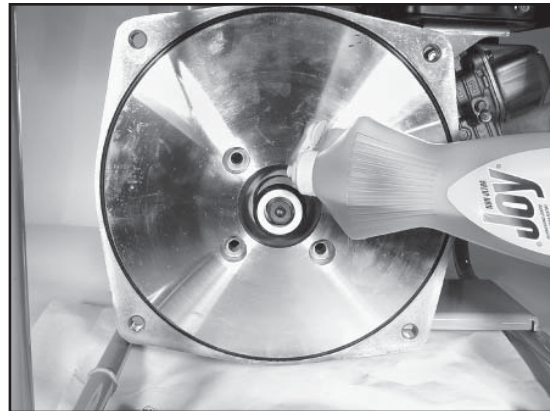

31. Push the seal on with two fingers or better yet, use your two thumbs. Making sure it is seating correctly.

Note: If the backplate is removed for whatever reason, it would help to install the seal before installing the backplate onto the engine.



32. Re-install rotating half of mechanical seal. Placing a little liquid detergent on the sealing lip will aid in reinstallation and keep the seal from tearing.

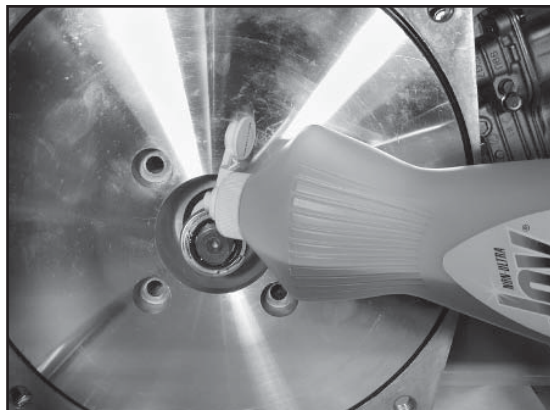

33. Re-install the shim(s) using the same number as was taken off. If new components such as impeller or volute was used, it may become necessary to re-shim with new shims for proper clearance. Check the procedure listed in a later step on how to perform this function.

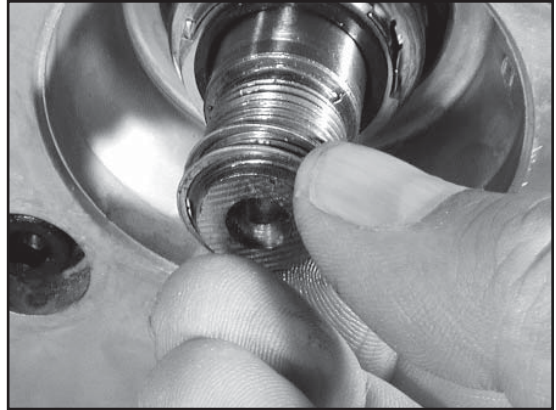

34. Re-install the spring.



35. Hand tighten the impeller onto the crankshaft. Make sure it is threaded on all the way. If impeller is not threaded to the full extend, the impeller face could strike against the inside of the volute.



36. To make sure the impeller is shimmed correctly, hold the volute against the back plate and check the clearance with a feeler gauge. If the clearance is larger than 0.0197in. then another shim must be added.
If there is less than 0.0078 in. between the volute and impeller, and the unit does not easily turn over with the rope start, then it is possible that a shim needs to be removed.

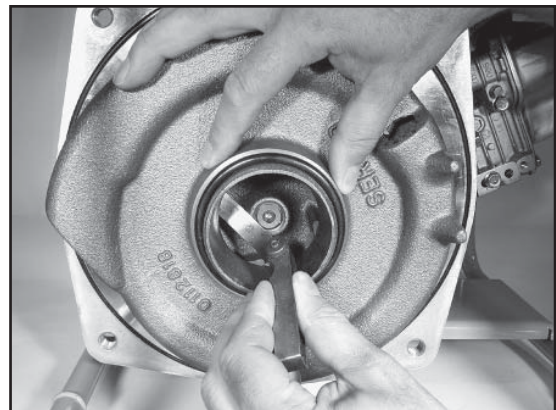

37. Re-tighten the impeller with a rubber mallet hitting the blades in a clockwise position. It should be tight enough that you should not be able to turn it loose by hand.

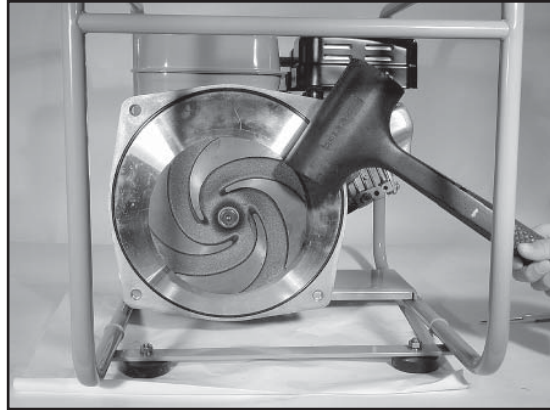

38. It is important that the volute slot matches with the cast in notch in the outer pump case. See arrow.



39. Re-install the volute into the outer case making sure the slot in the volute is resting on the casting molded into the outer case.

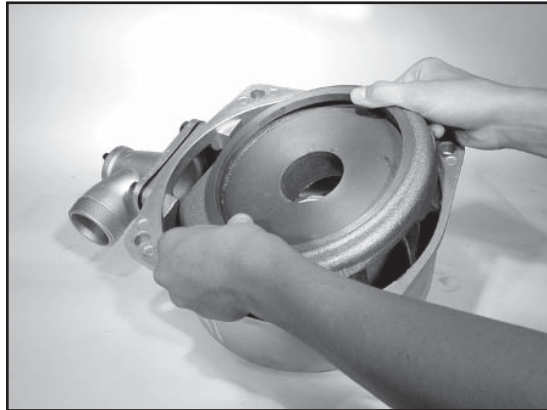

40. Replace the cover and volute onto the pump back plate. Install the four outer pump case bolts.

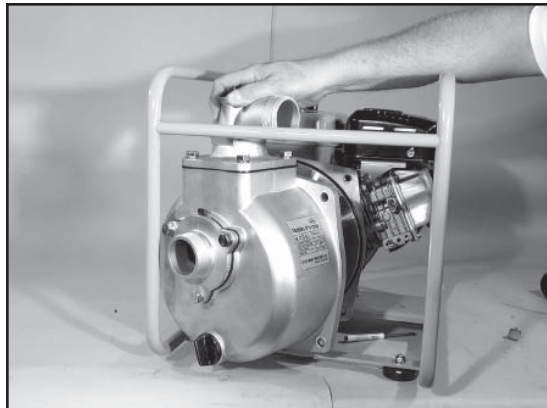

41. Tighten and torque the four bolts to a torque of 22 to 25 ft. lbs.

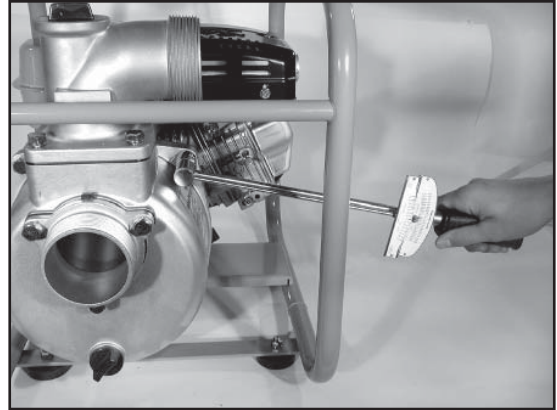

42. Once the case is torqued down, pull the recoil starter to check that pump and engine turn over freely. If OK, then re-fill with prime water. Next check the engine oil and start the engine. Apply vacuum pressure plate tester. Reading should be between 20 to 25 lbs of vacuum at sea level.

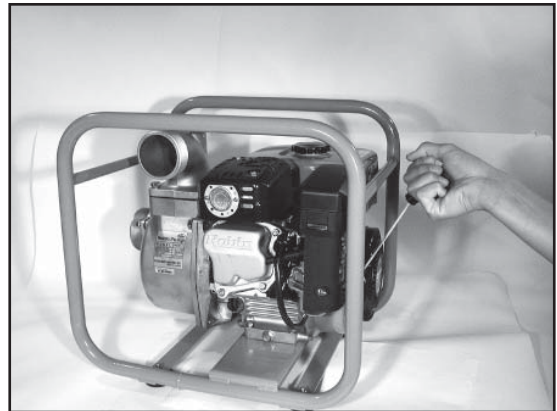

43. If it becomes necessary to remove the discharge nozzle, the following procedure is recommended. Loosen and remove the 4 bolts that hold the nozzle housing to the outer casing.

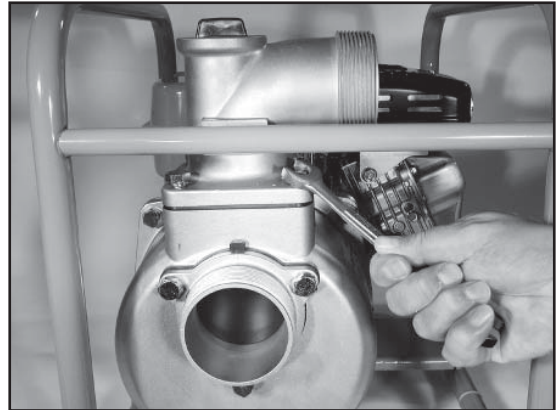

44. Remove the discharge nozzle and inspect the gasket for tears or breaks. Also check the nozzle casting for cracks.

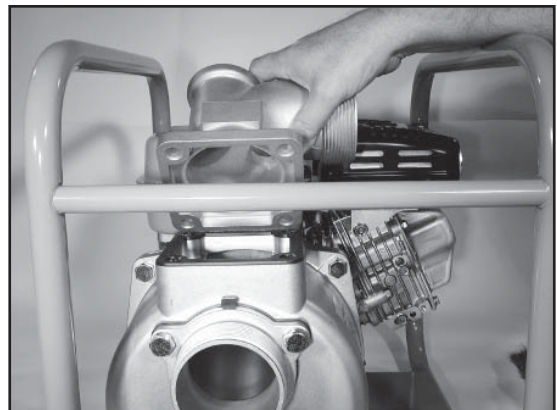

45. When replacing the gasket make sure the gasket is flat and not kinked. The gasket does not have a specified side to place on pump housing.

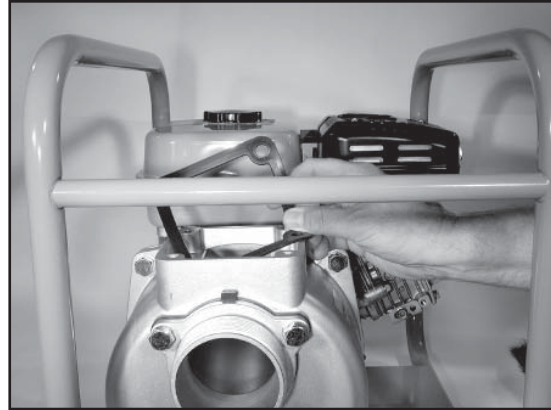

46. Re-install discharge nozzle and torque to 4.5 to 6 ft. lbs.

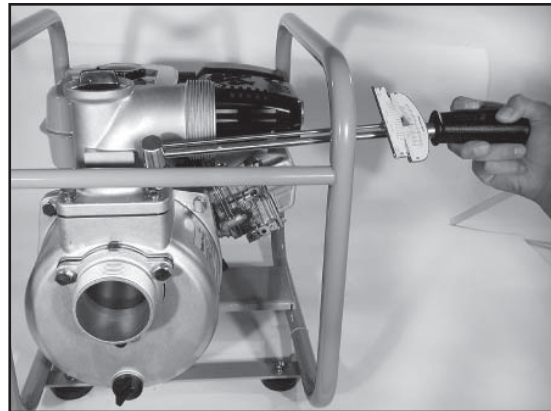

47. If it becomes necessary to remove the inlet nozzle, the following procedures are recommended. Loosen the three bolts that hold the casting to the outer pump housing.

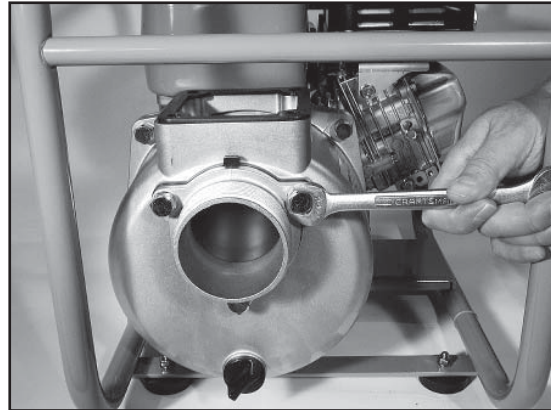

48. Lift the outer cover and gasket from the pump housing. Note position of gasket. Check gasket for cracks, nicks or other areas that might cause a air leak.

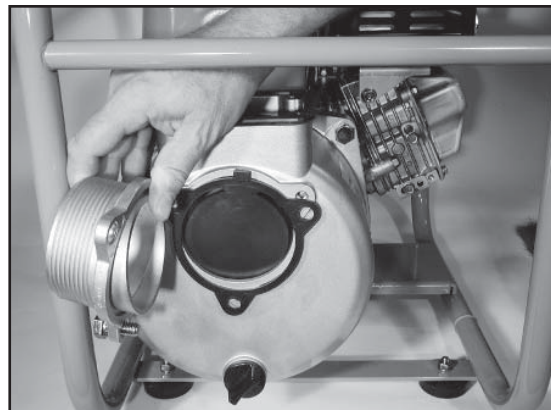

49. There is a correct way, and a wrong to install the inlet gasket. The casting marks must face towards the engine. If in doubt look at the picture in step 50.

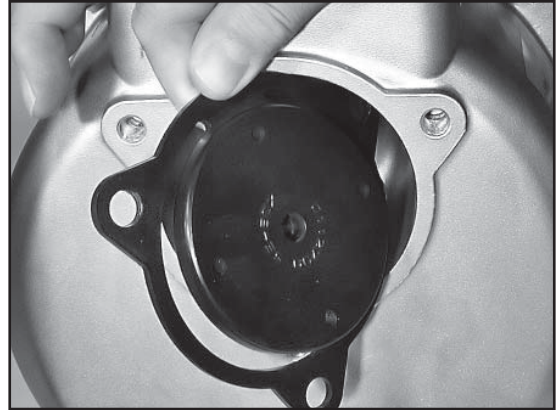

50. This picture shows correct way to install gasket. Make sure gasket is flat against the outer housing when reinstalling cover. Align holes and thread the three bolts into the nozzle and cover.



51. After reinstalling bolts, torque bolts to 4.5 to 6 ft. lbs

Note: The gasket tab must point upward to be installed correctly.

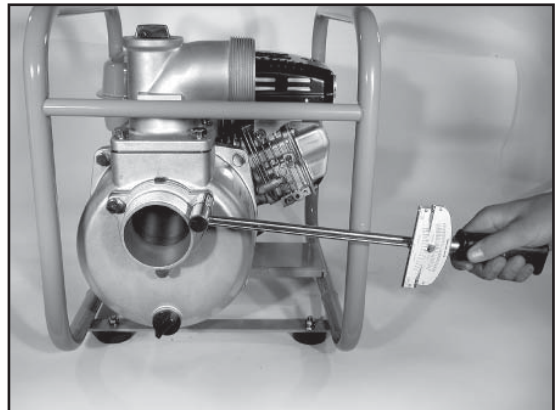

52. Pull the engine over with rope start to make sure there is no binding of pump components. Then fill with gas, oil, and prime water. Start engine and allow to warm up for a few seconds, then run the throttle at full speed. Place vacuum tester over intake opening and check gauge reading. The needle should rise to 20 to 25 inches of vacuum within a few seconds. If reading is lower, recheck the volute to impeller clearance as well as possible air leaks around gasket areas.

