



R E S I D E N T I A L P L A S T I C S E A T S



1200TC

Seats shall be No. 1200TC as manufactured by Bemis Manufacturing Co. Seats shall be heavy weight and injection molded of solid plastic. Seats shall be closed front with cover for elongated bowl and feature large molded-in bumpers. Color matched Top-Tite® hinges contain stainless steel pintles, non-corrosive top-tightening bolts, wing nuts and no-slip washers. The "locked-in" Top-Tite® hinge design will prevent wobbling. The molded-in bumpers provide easy cleaning. Color to be _____. (specify white or fixture manufacturer's color)

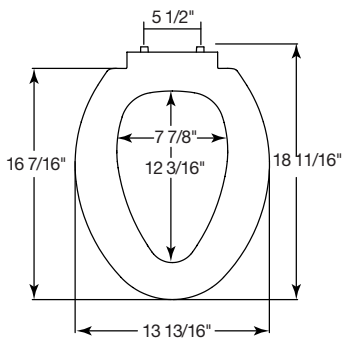

Ring thickness is 5/8"
 Ring thickness including the bumper is 29/32"
 Height of the seat with cover is 2-19/32"



**TOP-TITE® HINGES
 FEATURE
 NO-SLIP WASHER**



**"LOCKED-IN"
 TOP-TITE® HINGE**

