



PREMIUM MOLDED WOOD SEATS

MODEL 595

Church premium seats add a dramatic new dimension to style and fashion. These seats are engineered with careful attention to every detail. Highest quality, sleek, timeless design from Church.

- **ELONGATED SEAT, OPEN FRONT WITH COVER**
- **MOLDED WOOD**
- **HEXTITE™ INSTALLATION SYSTEM WITH NON-CORROSIVE TOP-TIGHTENING BOLTS, WING NUTS AND NO-SLIP WASHERS**

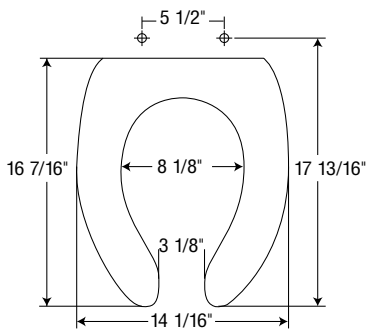

Seats shall be No. 595 as manufactured by Church Seats. Seats shall be molded wood, multi-coat enamel finish with open front and cover to fit elongated bowl. Color-matched bumpers and hinges. Hextite™ installation system with non-corrosive top-tightening bolts, wing nuts and no-slip washers. Color to be white.

Ring thickness is 3/4"
Ring thickness including the bumper is 1-1/16"
Height of the seat with cover is 1-7/8"

