

# MODEL B100-81 Link Spring Assembly

- PARTS LIST**
- 4 - Universal Brackets
  - 8 - 1/4" Carriage Bolt
  - 8 - 1/4" Nut

Position bracket (A) against spring frame (B) with long end of bracket down. Align slots on spring frame and bracket (see figure 1). Insert two 1/4" Carriage Bolts (C) through bracket and frame and fasten "finger" tight with two 1/4" nuts (D). Complete this procedure on all four corners of the spring frame.

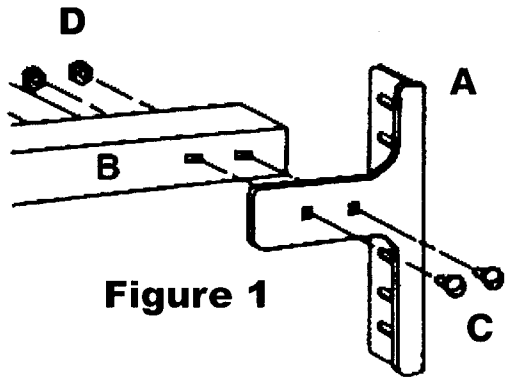

**Figure 1**

Position spring frame with brackets attached within assembled bed. Adjust bracket to correct bed width by sliding bracket in or out. Now "tool" tighten nuts to 1/4" Carriage Bolts.

**Figure 2**

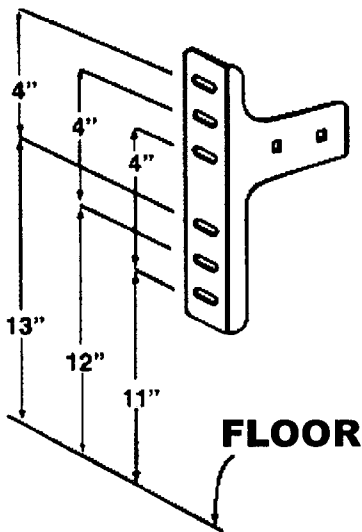

Select height of spring frame by positioning brackets on bed's mounting studs or bolts (see figure 2). Spring frame may be adjusted to high, low or medium. Be sure to allow sufficient clearance under spring frame for pop-up unit.

Fasten spring frame to bed using nuts on bed's mounting bolts or studs provided by bed manufacturer.

