

Converting the Halo

Converting to Sofa

Standing at the side of the unit (from bed position), lift backrest to the desired position and secure in place by releasing to the sound of a click.

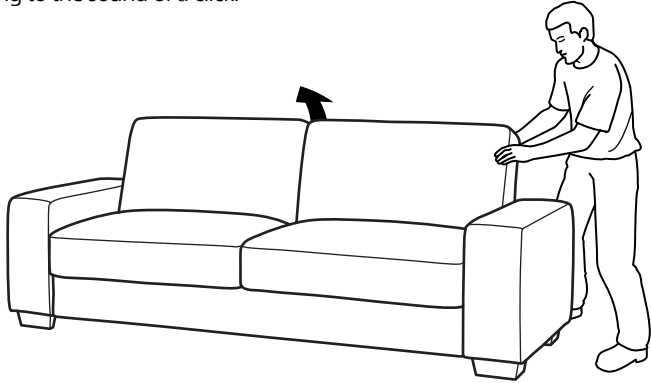

Converting to Lounger

In bed position, lift backrest upwards with each click sound until a desired lounge position is reached.

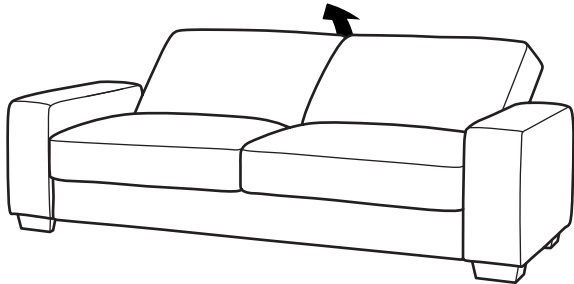

Converting to Bed

From sofa or lounge position, lift backrest all the way upwards until the last click is heard which unlocks the mechanism and carefully return to a flat position.

IMPORTANT: Ensure that the support legs are extended out (behind the backrest) when using it as a bed.

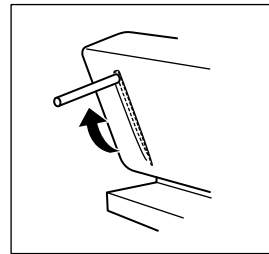
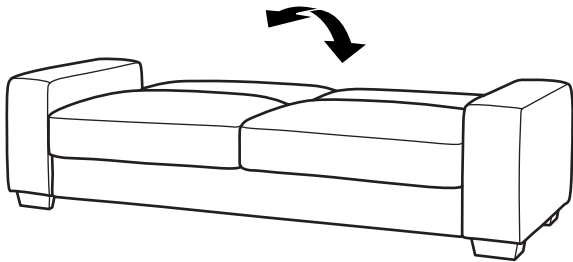

Halo

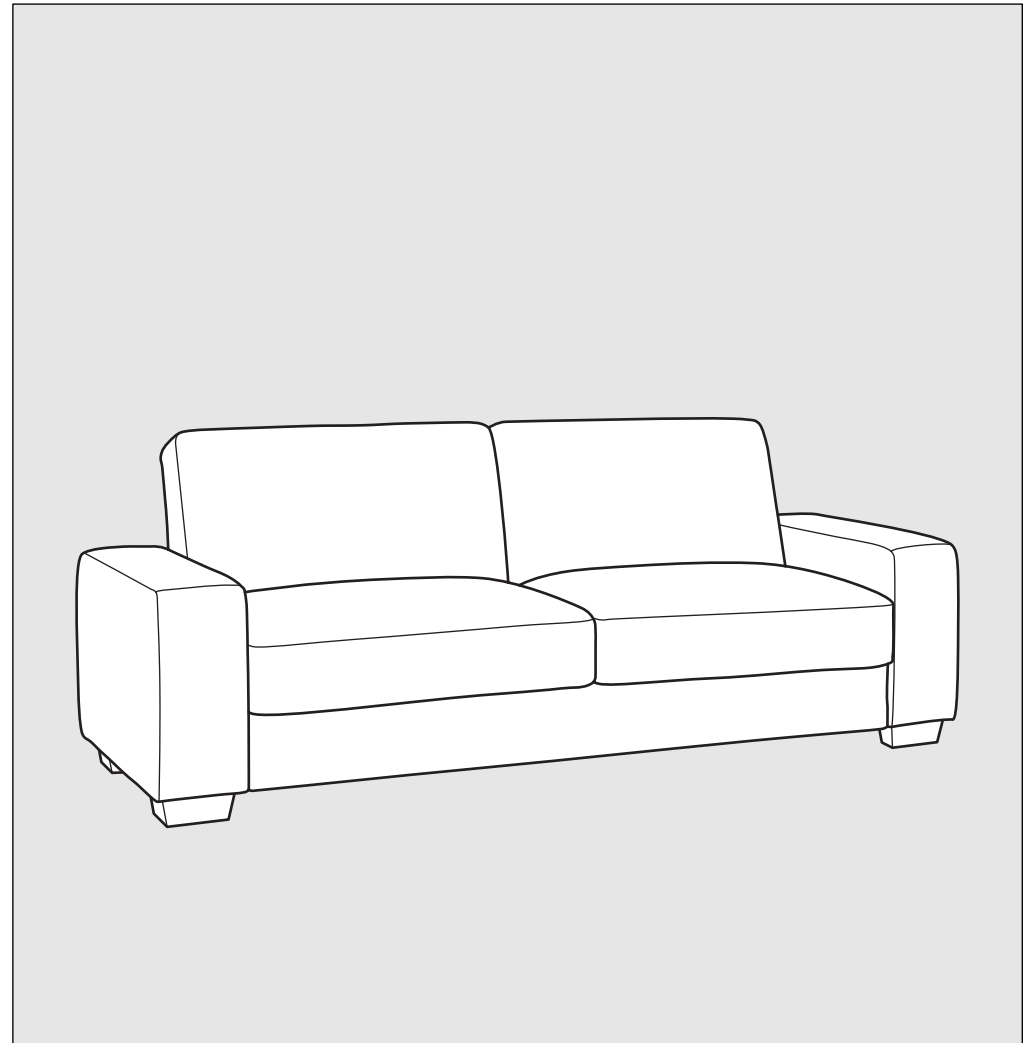

Parts and Hardware

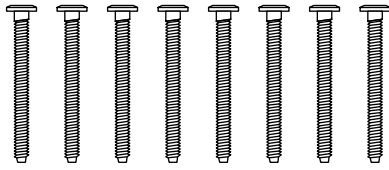

Bolt

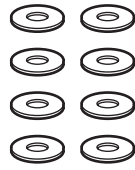

Washer



Allen Key

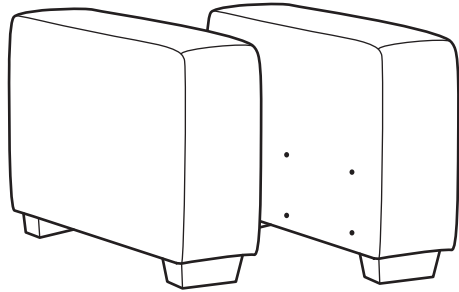

Armrest

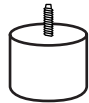

Center Support Leg

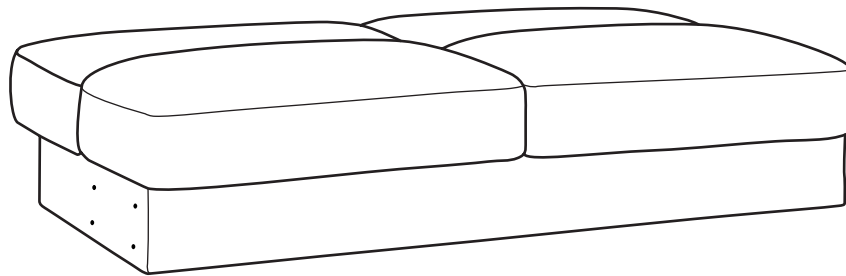

Sofa Body

Assembling the Halo

- 1** Carefully unpack and place sofa body unit upright on a clean flat surface to show the base as shown.
- 2** Unzip both side compartments on the base and locate the pre-drilled holes inside. Align armrest into position (see below) and secure with four bolts and washers for each armrest from inside with Allen key.
Repeat step for other armrest, ensuring both are fully secured and zip shut when complete.

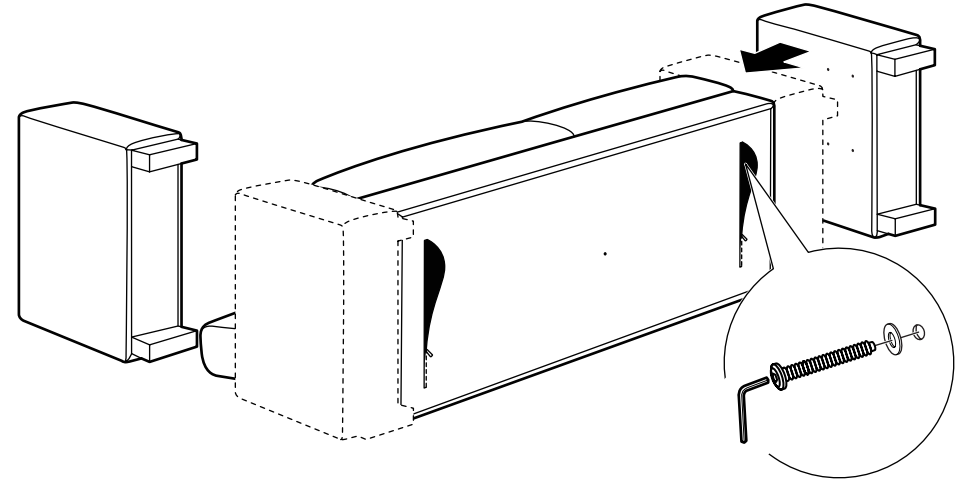

- 3** Secure center support leg by screwing into pre-drilled holes on center of the base by hand and avoid overtightening.

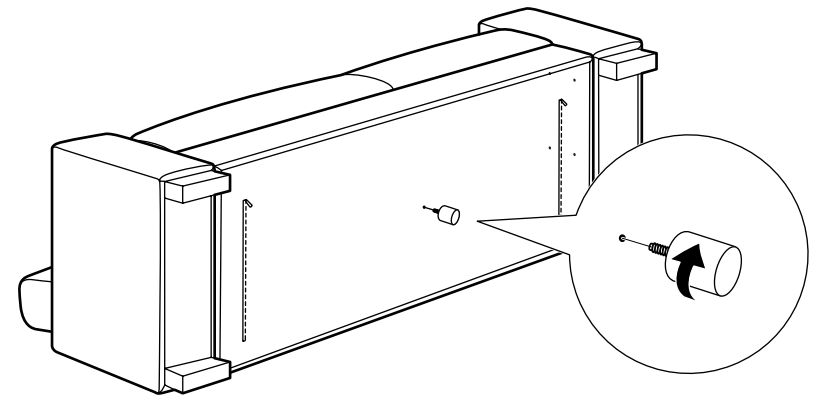

- 4** Finally, carefully lift and turn assembled unit onto its legs. Two persons required to avoid personal injury.