



Intelligent Design™

Model:  
TGD200, TGD201, TGD202

**Step 1**

Attach back of arm by threading the dowel screw attached to the arm into the pilot hole until the arm is snug against the back leg.

- (1) CHAIR
- (2) ARM ASMB (LH/RH)
- (1) HARDWARE PACK

**Step 2**

Attach (A) bolts thru the seat frame into the insert nuts on the arm supports

**TOOLS NEEDED**

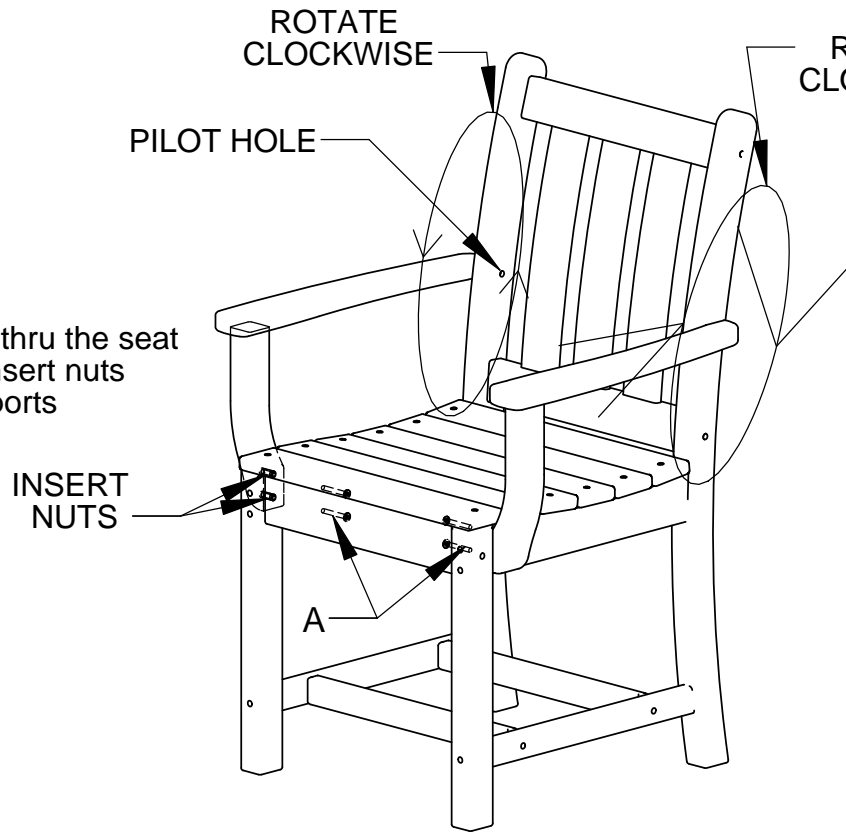
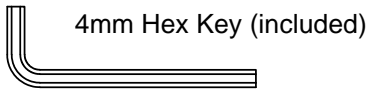

TGD200

ROTATE  
CLOCKWISE

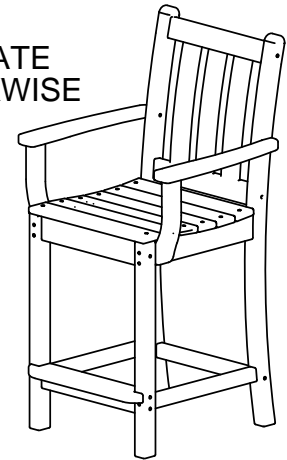

TGD201

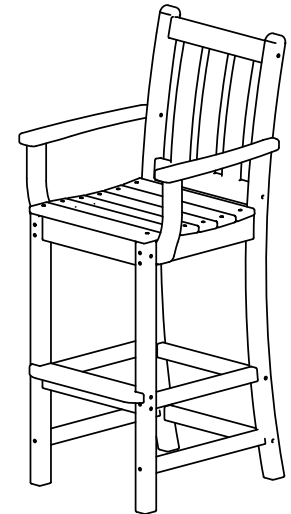

TGD202

Qty.	Description
4	A -1/4-20 X 1-3/4 WAFER SHCS
1	HDWPK-#8 SCREW PLUGS, 4X (EXTRAS)



Models: RT248, RCT248, RRT248, RBT248  
RT348, RCT348, RRT348, RBT348

- (1) Table top
- (4) Leg
- (2) Foot
- (2) Brace
- (1) Hardware pack

### TOOLS NEEDED

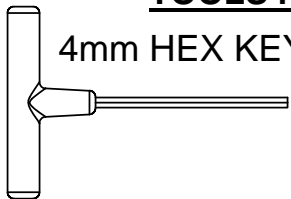

4mm HEX KEY: INCLUDED

**Step 1**  
Attach feet to legs using  
(4) 3 1/4" Chair bolts.

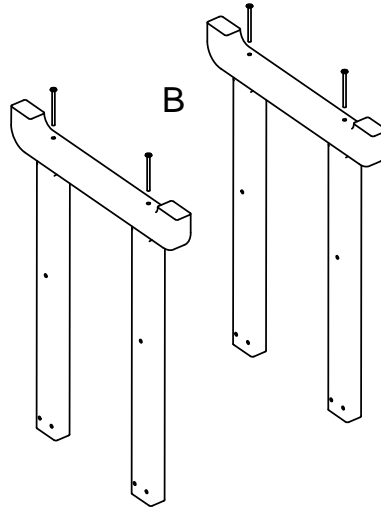

**Step 2**  
Lay the table top on a flat surface.  
Attach the leg assemblies to the table top using  
(8) 3" screws.

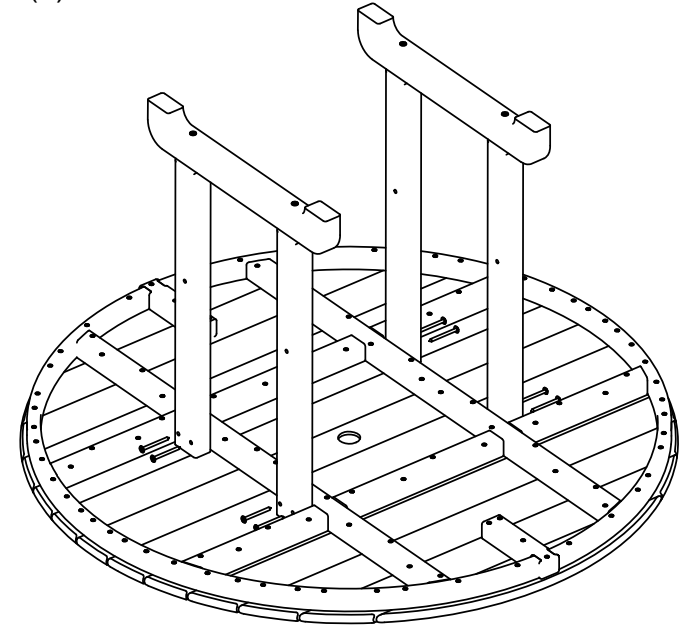

**Step 3**  
Attach leg braces using  
(4) 3" screws.

Set table upright and tighten all bolts

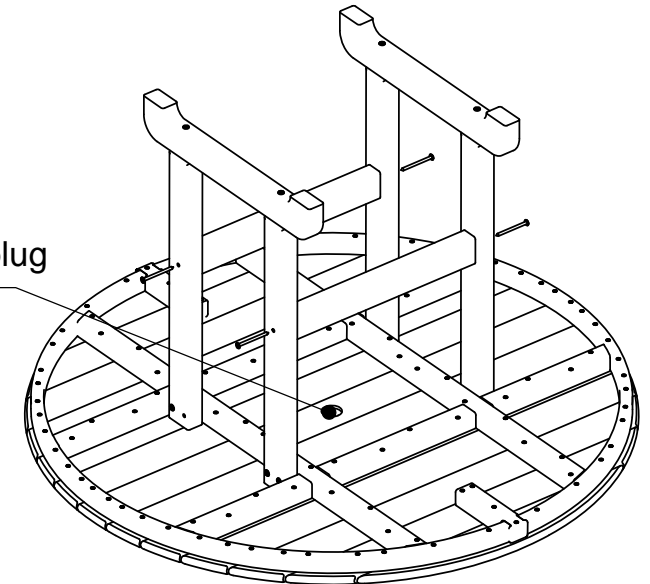

Qty.	Description
12	A - 14 X 3 SOCKET WAFER "B"
4	B - 1/4-20 X 3-1/4 WAFER SHCS FINE THREAD