

Models: TGD100, TGD101, TGD102

Features

1. No assembly required
2. Extra screw plugs included

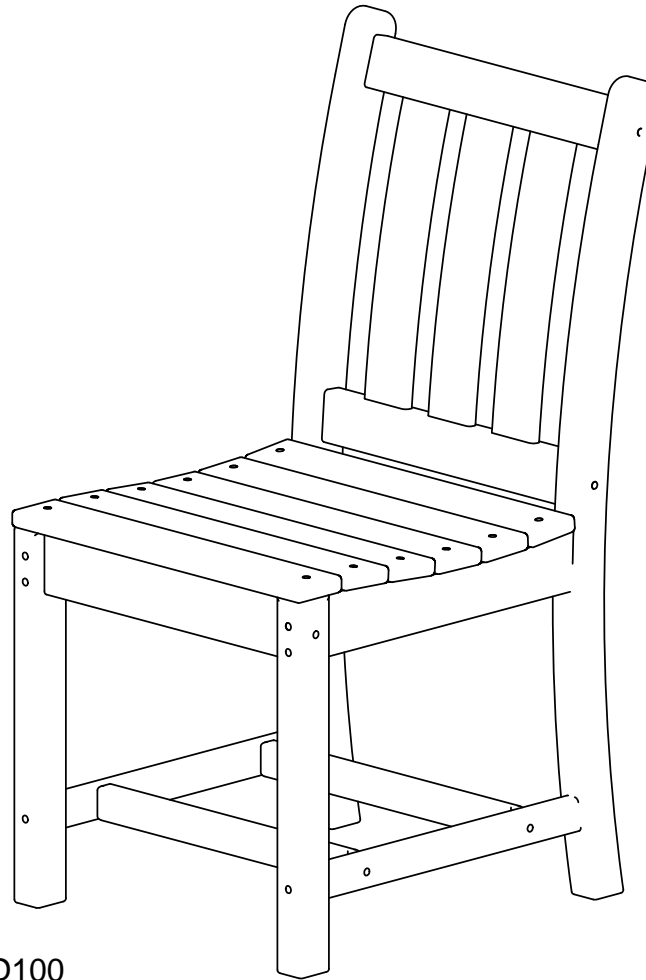

TGD100

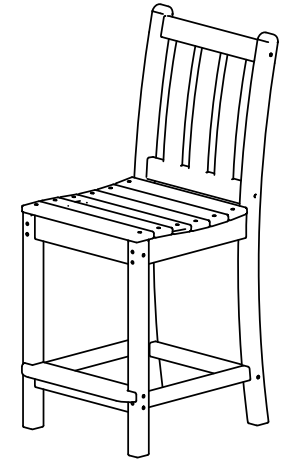

TGD101

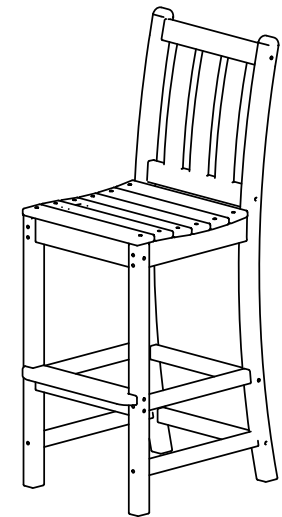

TGD102

QTY	DESCRIPTION
-----	-------------

1	
---	--



	HDWPK-#8 SCREW PLUGS, 4X (EXTRAS)
--	-----------------------------------



Intelligent Design™

Model:
TGD200, TGD201, TGD202

Step 1

Attach back of arm by threading the dowel screw attached to the arm into the pilot hole until the arm is snug against the back leg.

- (1) CHAIR
- (2) ARM ASMB (LH/RH)
- (1) HARDWARE PACK

Step 2

Attach (A) bolts thru the seat frame into the insert nuts on the arm supports

TOOLS NEEDED

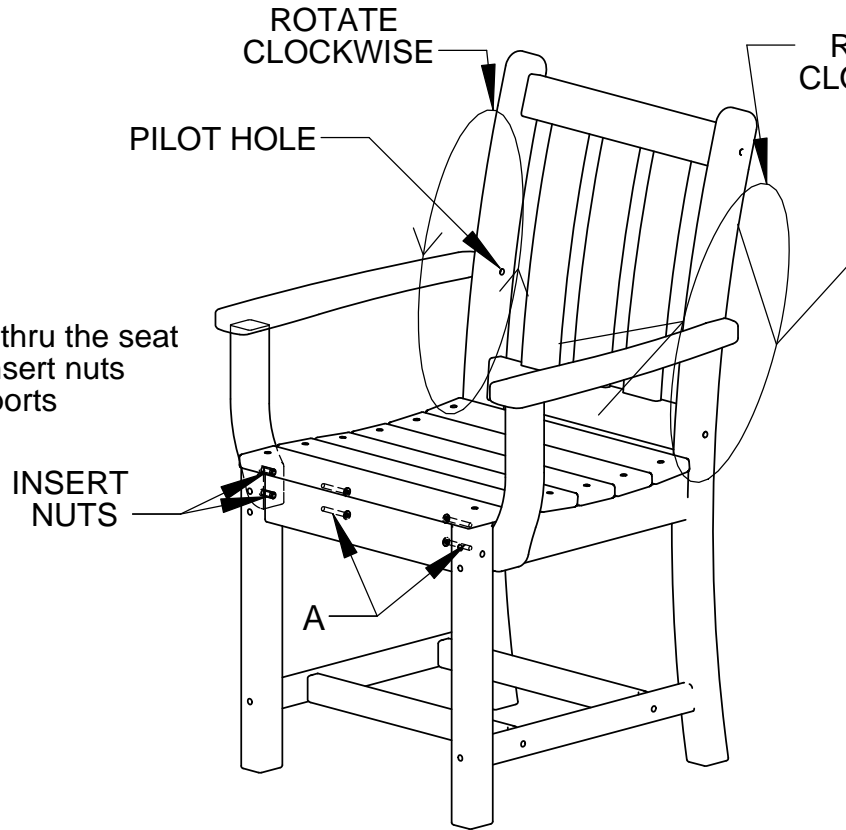
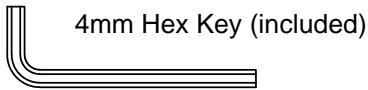

TGD200

ROTATE
CLOCKWISE

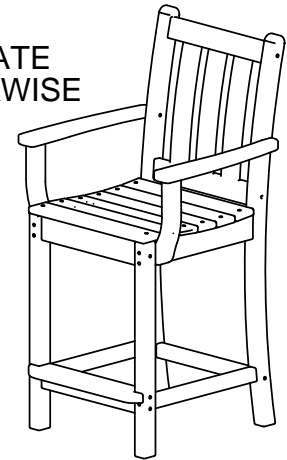

TGD201

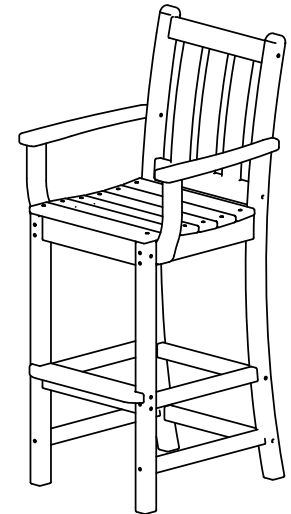

TGD202

Qty. Description

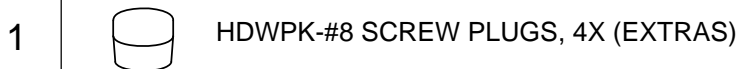
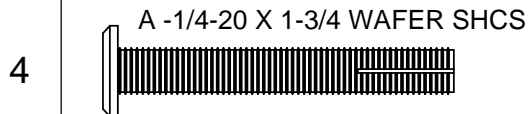



Intelligent Design™

Model: NCCT3772, NCT3772, NCRT3772, NCBT3772

- (1) Table top
- (8) Leg
- (4) Foot
- (4) Brace
- (1) Hardware pack

Step 2
Lay the table frame on a flat surface.
Attach the leg assemblies to the frame using
(16) .27x2½" screws - Do not tighten yet.

Step 3
Attach braces to the leg assemblies using
(8) .27x3" screws

Step 1
Attach feet to legs using (8) 2½" Chair bolts.

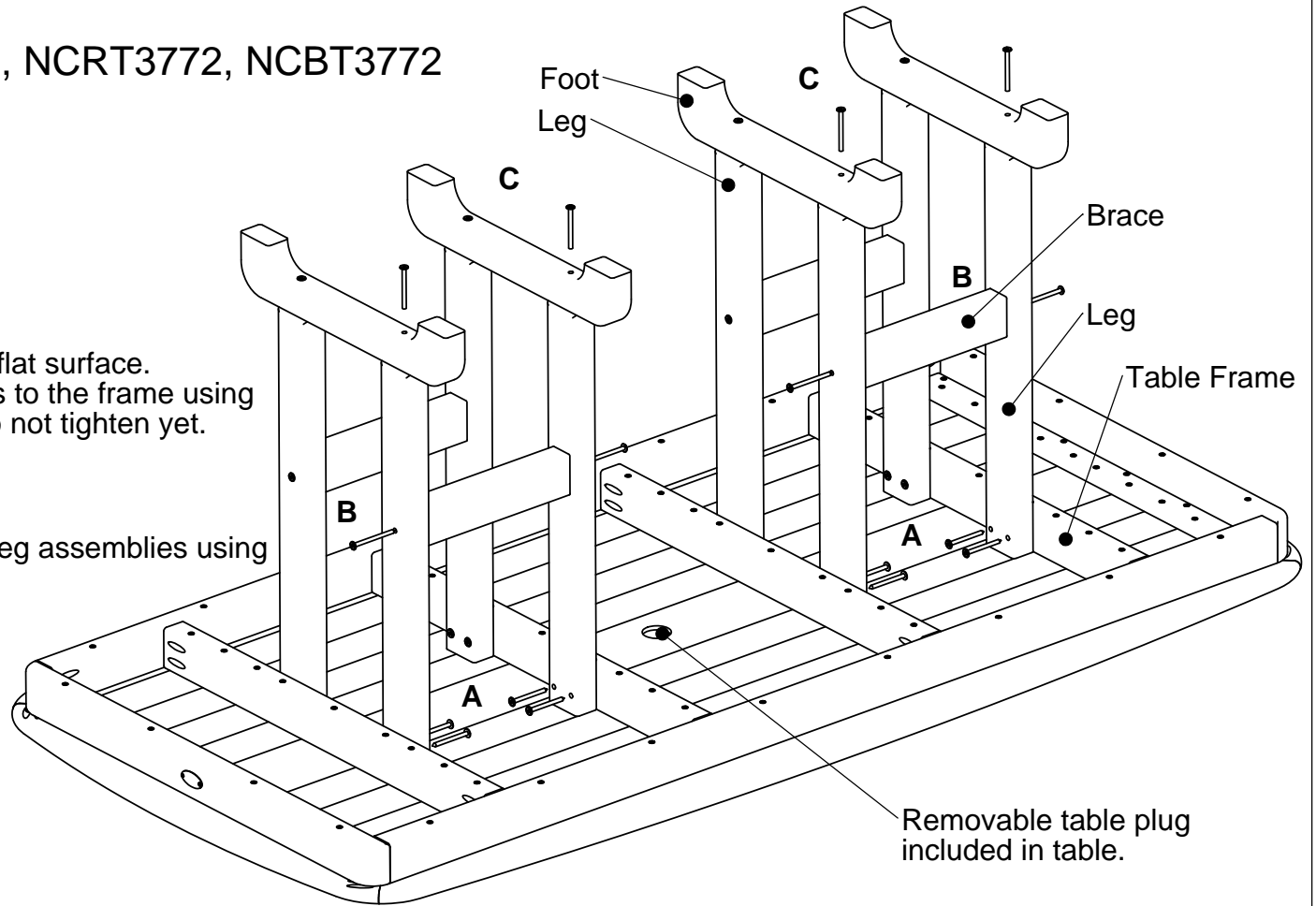

TOOLS NEEDED

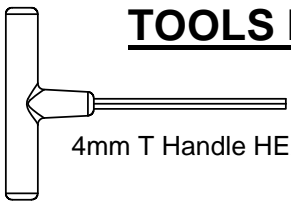

4mm T Handle HEX KEY: INCLUDED

Qty.	Description
16	A - .27 X 2-1/2 SOCKET WAFER A
8	B - .27 X 3 SOCKET WAFER A
8	C - 1/4-20 X 2-1/2 WAFER SHCS

Step 4
Set table upright and tighten all bolts.