

Model: TGG48

- (1) Seat
- (1) Back
- (2) Sideframes
- (2) Glider Base Frames
- (2) Glider Cross Brace
- (1) Hardware pack

TOOLS NEEDED

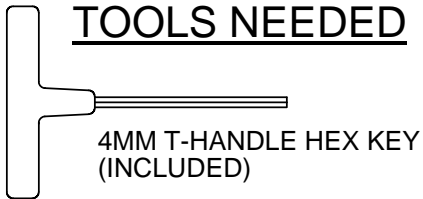

***NOTE:** ALL FINE THREAD BOLTS (A) AND (B), WILL THREAD INTO EITHER THE TUBE OR AN INSERT NUT. COURSE THREAD SCREWS GO STRAIGHT INTO THE POLY

Step 1

Attach sideframes to seat using (4) 1½" chair bolts. DO NOT TIGHTEN!!

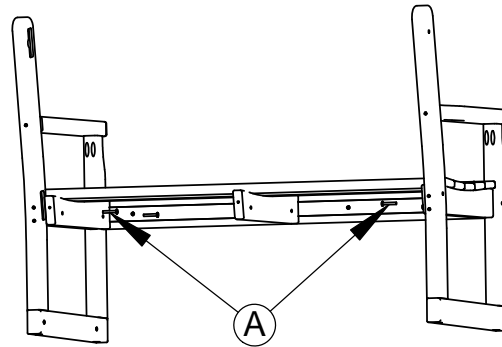

Step 2

- Attach back to sideframes using (2) 2¼" chair bolts into the tube on top and (4) 2½" screws on bottom

- Attach center of the back to the seat using (1) 2½" screw

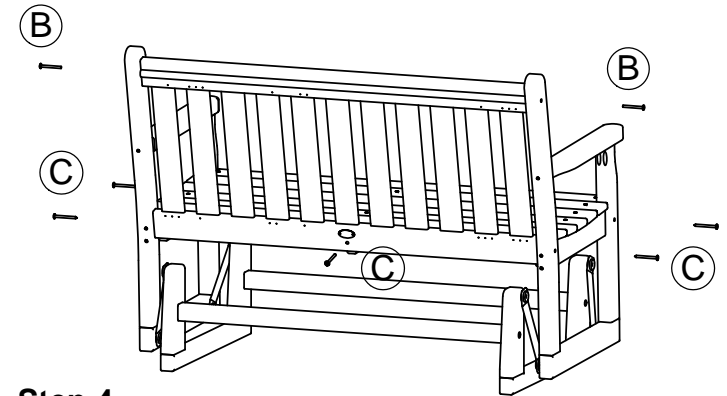

Step 3

-Tighten the 1½" chair bolts from Step 1

-Attach cross braces to the glider base frames with (4) 2½" screws

Step 4

-Attach glider base to bench with (4) 1½" chair bolts

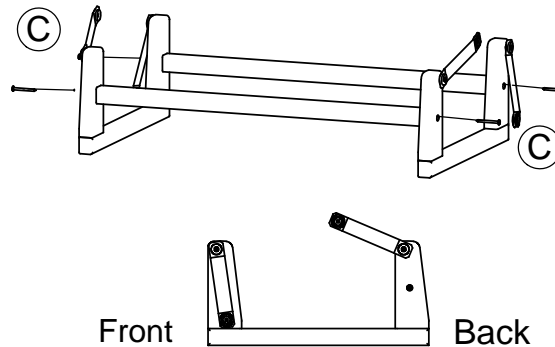

Note: The direction of the pillars on the base. The angled edges should be facing the back when assembled

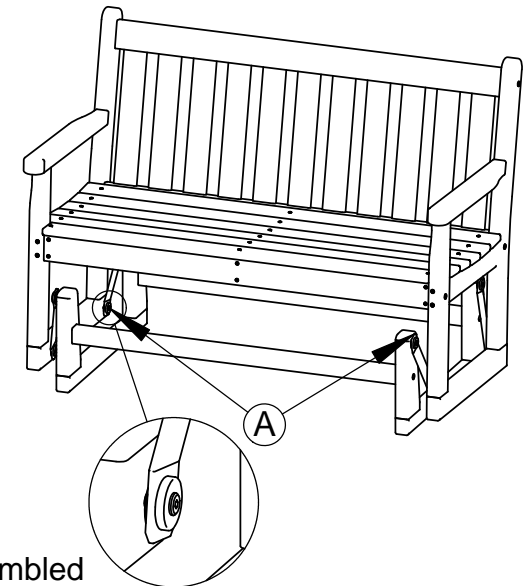

QTY.	DESCRIPTION
8	A - 1/4-20 X 1-1/2 WAFER SHCS FINE THREAD
2	B - 1/4-20 X 2-1/4 WAFER SHCS FINE THREAD
9	C - .27 X 2-1/2 SOCKET WAFER A