

Model: TD102

- (1) Seat assembly
- (1) Front assembly
- (1) Back leg assembly
- (1) Foot rest
- (2) Short brace
- (2) Long brace
- (1) Hardware pack

Step 1
Attach front assembly to the seat assembly and with (4) 3" screws

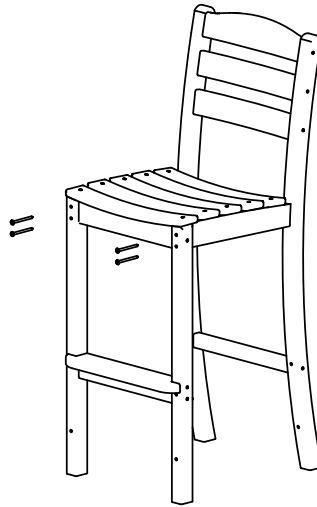

Step 2
Attach back leg assembly to seat assembly using (4) 3" screws

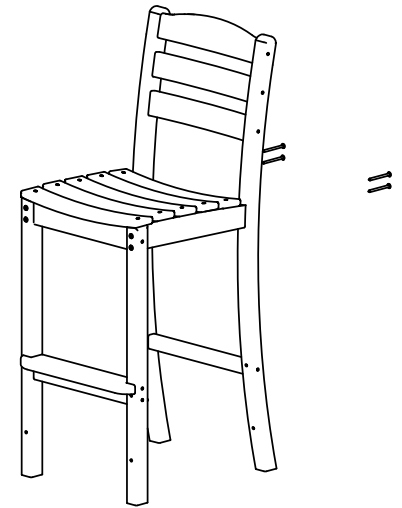

TOOLS NEEDED

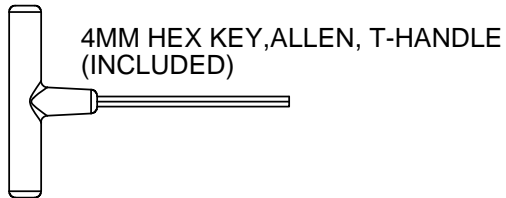

Qty.	Description
16	A - .27 X 3 SOCKET WAFER A

Step 3
Attach braces between the front and back legs with the remaining (8) 3" screws.

Note: Angle cut on brace should be attached to the back leg

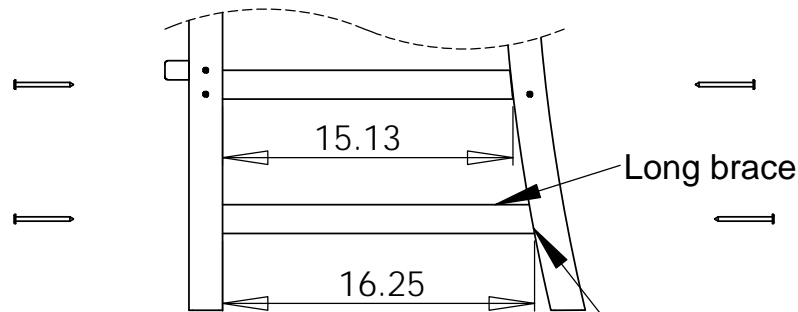

Angle cut with long edge on bottom (both braces)

