

WPS6 Instruction Sheet

Do not completely tighten screws until step 5



H. WILSON

H. Wilson Company
 Address: 2245 Delany Rd.
 Waukegan, IL
 Phone: 800.245.7224
 Fax: 800.245.8224
 Email: sales@hwilson.com
 web: www.hwilson.com

APRIL 2010 - REV00

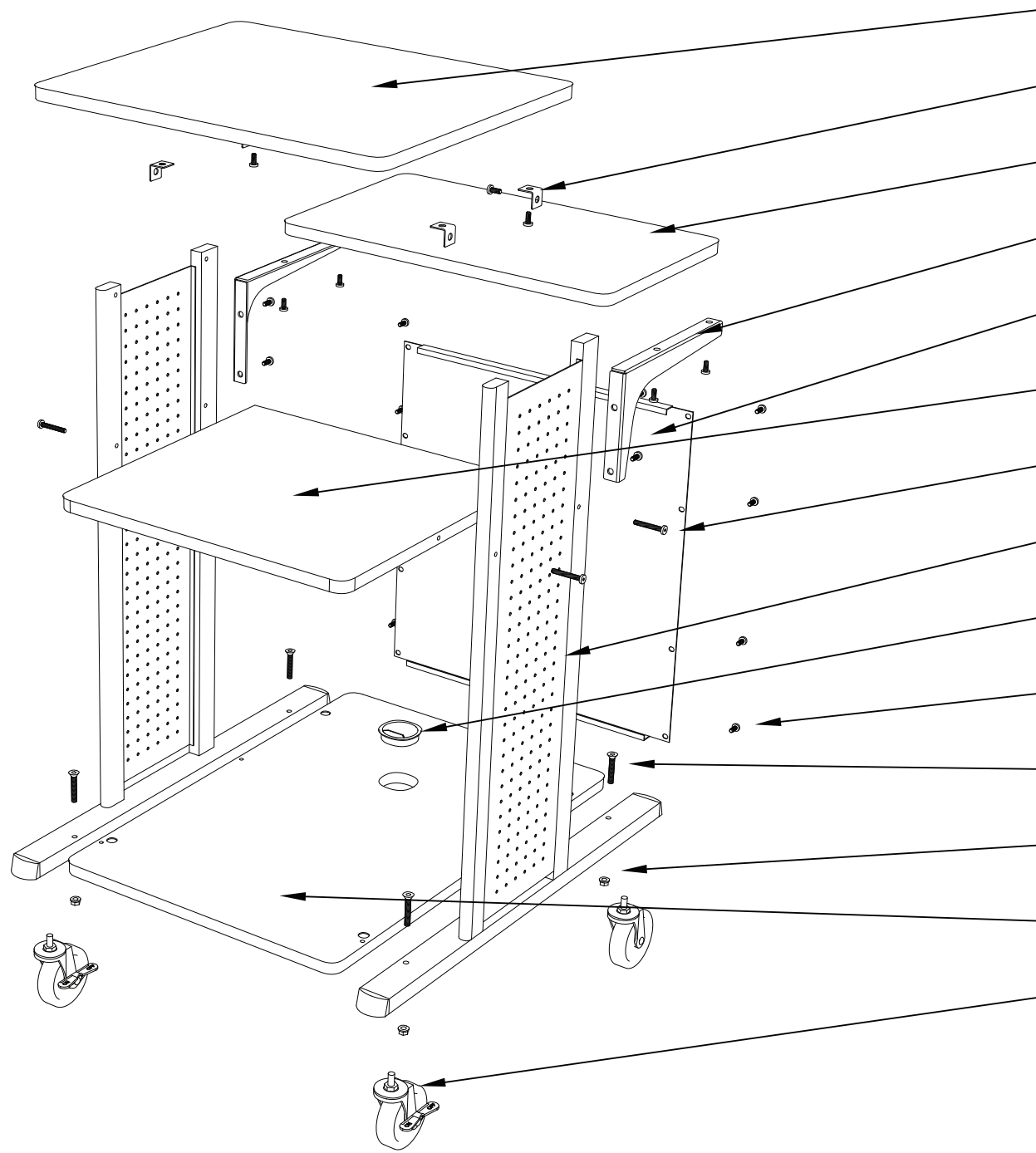

- A. 1 - Top (23 5/8" x 19 1/4")
- B. 4 - Small L brackets
- C. 1 Adjustable shelf (23 5/8" x 13 7/8")
- D. 2 - Adjustable shelf brackets (Left & Right pair)
- E. 1 - Metal back panel
- F. 1 - Middle shelf (20 3/8" x 19 1/4")
- G. 4 - M6 x 35 Allen panhead screws
- H. 2 - Legs (Left & Right pair)
- I. 1 - Cable grommet pack
- J. 24 - M6 x 10 Allen panhead screws
- K. 4 - M10 x 35 Allen screws
- L. 4 - M10 nuts
- M. 1 - Bottom panel (20 3/8" x 30 5/8")
- N. 4 - Casters (2 w/ Brake, 2 w/o Brake, Wrench)
- O. 1 - Small M6 Allen wrench
- P. 1 - Large M10 Allen wrench
- Q. 4 - Small grommets
- R. Stickers

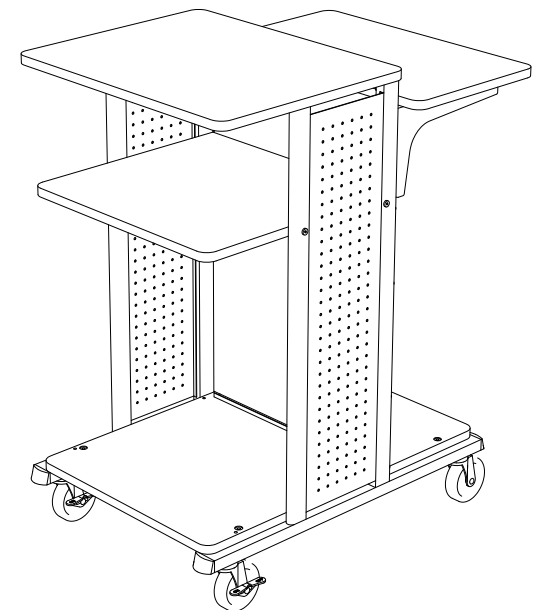
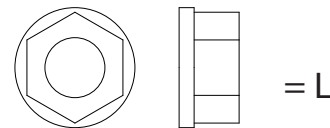
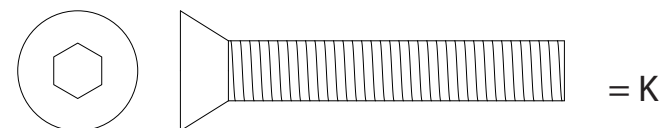
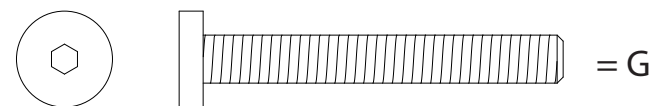
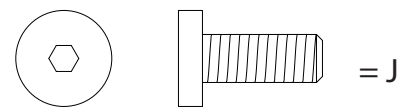

WPS6 Instruction Sheet

Do not completely tighten screws until step 5



H. WILSON

H. Wilson Company
Address: 2245 Delany Rd.
Waukegan, IL
Phone: 800.245.7224
Fax: 800.245.8224
Email: sales@hwilson.com
web: www.hwilson.com

APRIL 2010 - REV00

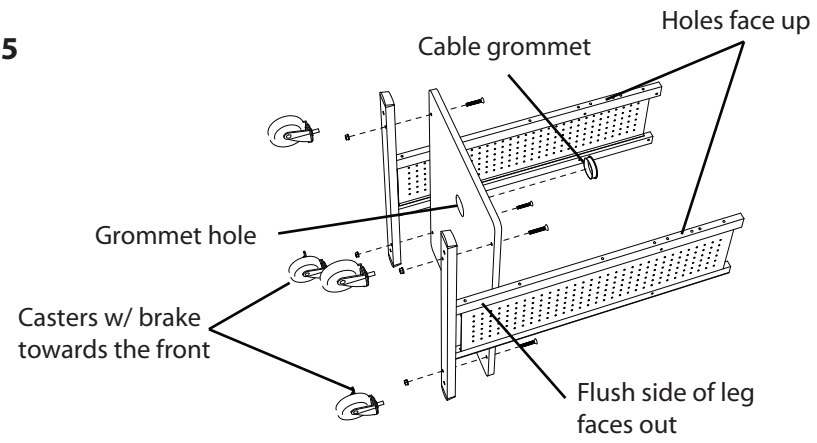

Step 1: Using the large Allen wrench(P), install the base panel(M.) to the legs(H) with 4 - M10x35 Allen screws(K) and nuts(L). Install the Casters(N) and tighten with the caster wrench. Install the cable grommet(I), and cover remaining holes with the small grommets(Q) and sticker(R).

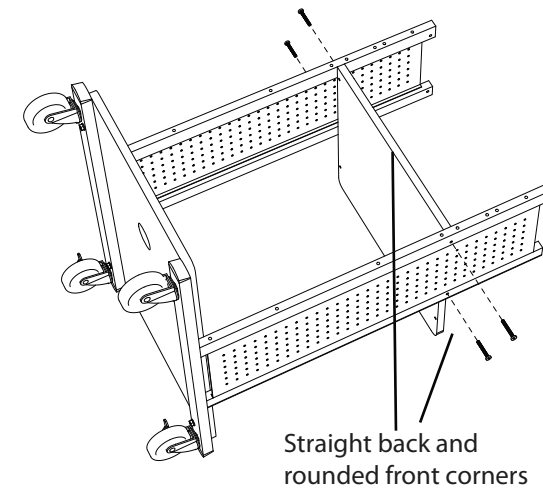

Step 2: Using the small Allen wrench(O), install the middle shelf(F) with 4 - M6x35 Allen screws(G).

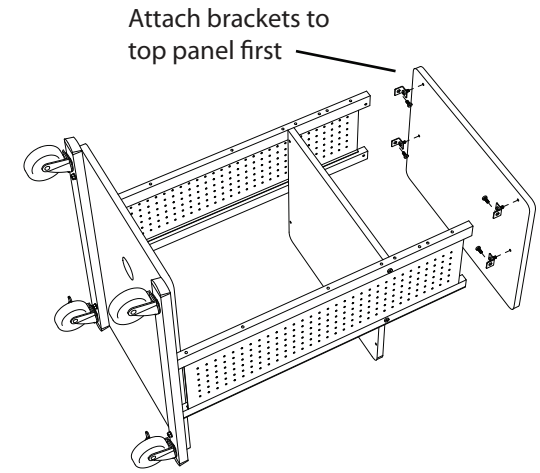

Step 3: Using the small Allen wrench, install the top(A) to the legs with 4 - small L brackets(B) and 8 - M6x10 Allen screws(J).

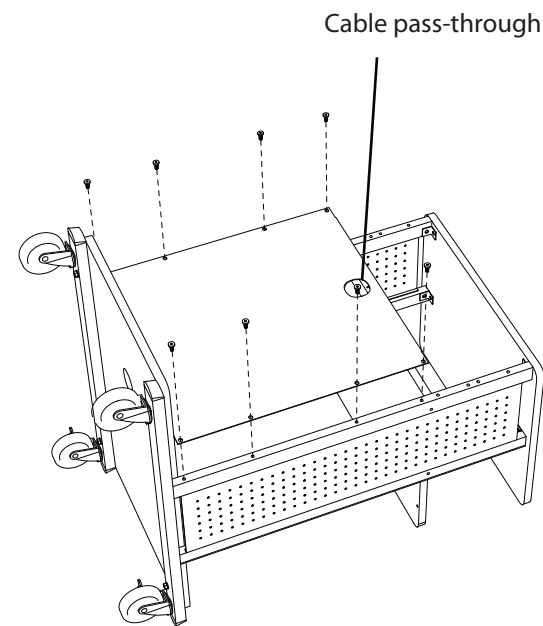

Step 4: Using the small Allen wrench, install the back panel(E) to the legs with 8 - M6x10 Allen screws(J).

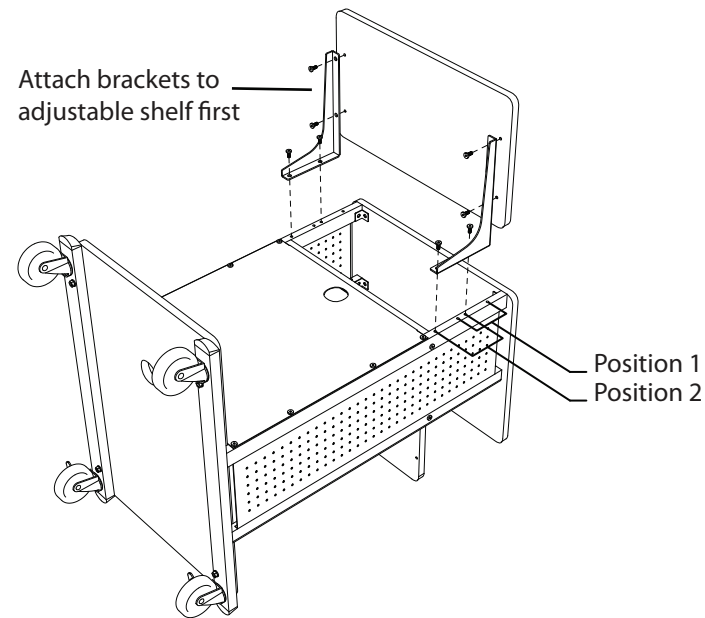

Step 5: Using the small Allen wrench, install the adjustable shelf(C) to the brackets(D) and legs with 8 - M6x10 Allen screws(J). **Tighten all screws down.**

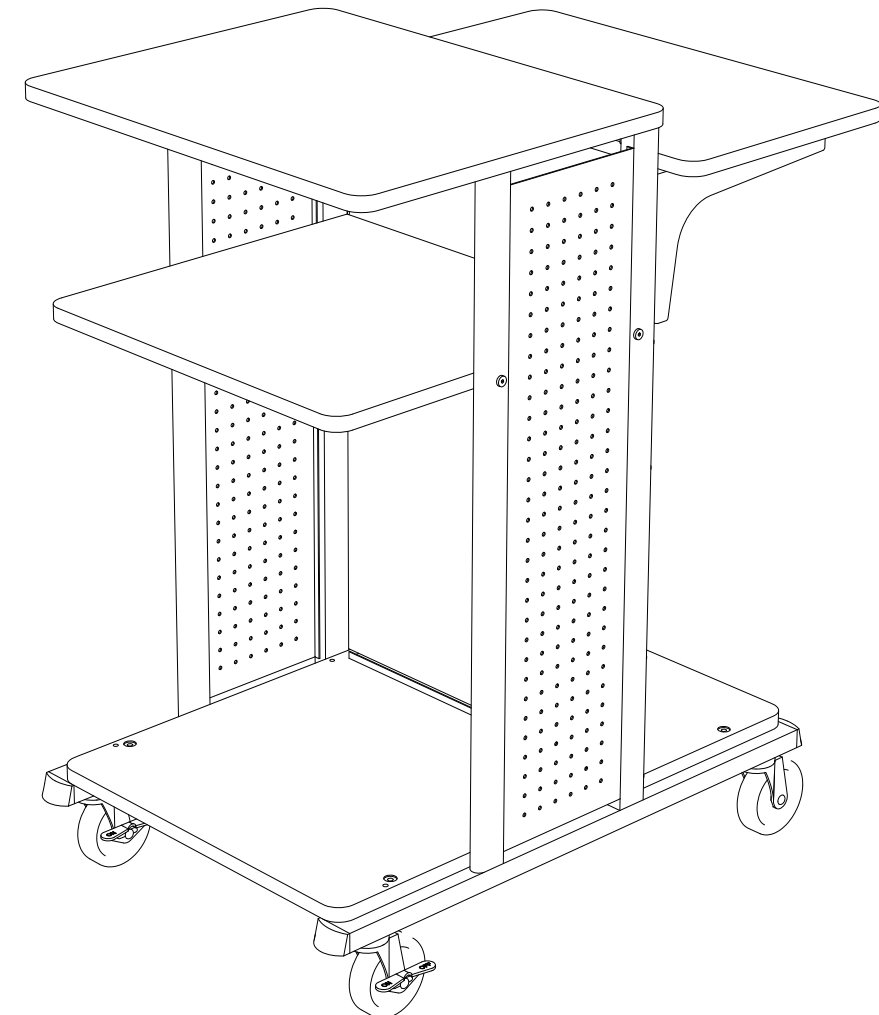

WPS6C Instruction Sheet

Do not completely tighten screws until step 5



H. WILSON

H. Wilson Company
 Address: 2245 Delany Rd.
 Waukegan, IL
 Phone: 800.245.7224
 Fax: 800.245.8224
 Email: sales@hwilson.com
 web: www.hwilson.com

APRIL 2010 - REV00

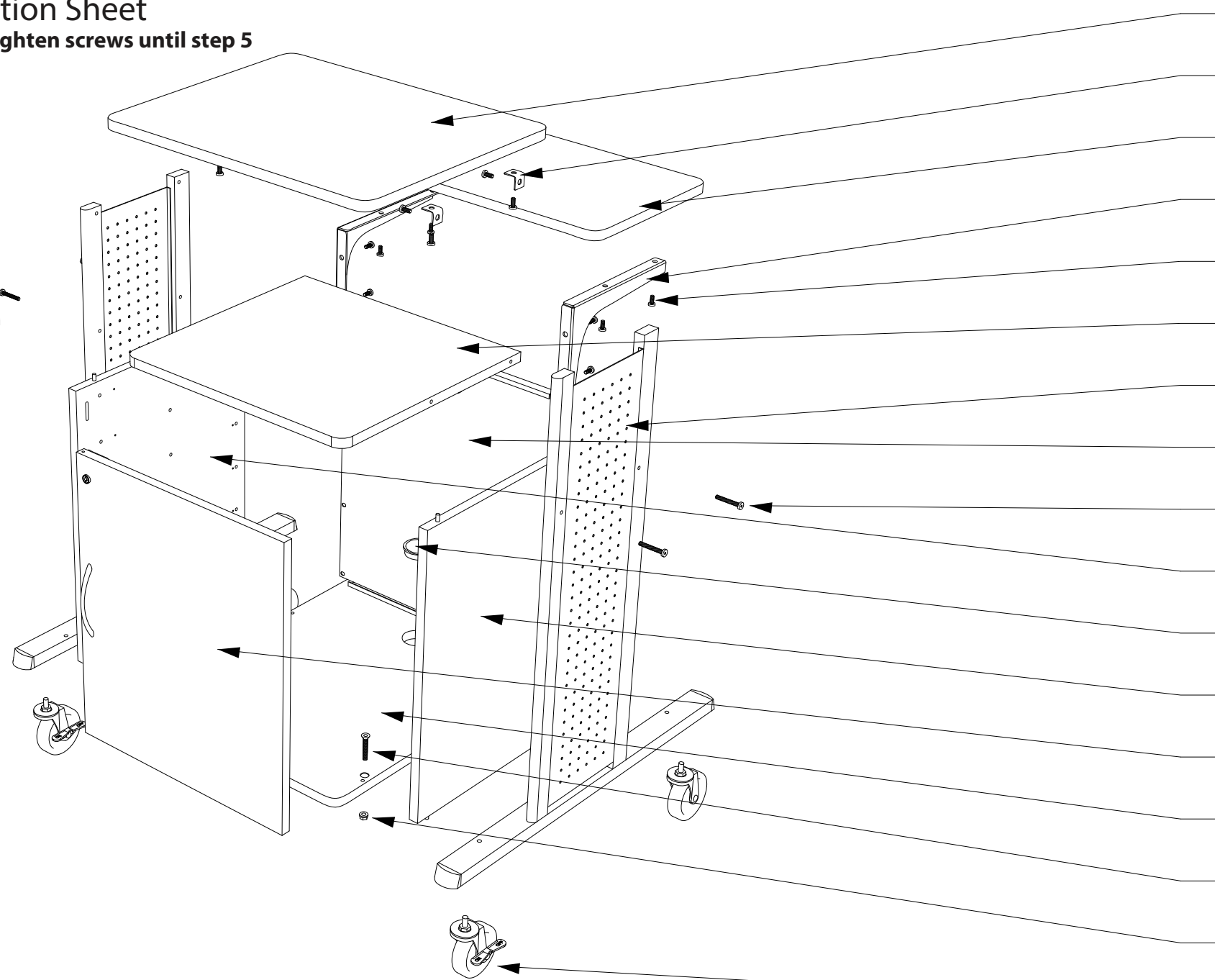

- A. 1 - Top (23 5/8" x 19 1/4")
- B. 4 - Small L brackets
- C. 1 Adjustable shelf (23 5/8" x 13 7/8")
- D. 2 - Adjustable shelf brackets (Left & Right pair)
- E. 24 - M6x10 Allen panhead screws
- F. 1 - Middle shelf (20 3/8" x 19 1/4")
- G. 2 - Legs (Left & Right pair)
- H. 1 - Metal back panel
- I. 4 - M6x35 Allen panhead screws
- J. 1 - Left cabinet panel (18 3/16" x 23 1/4")
- K. 1 - Cable grommet pack
- L. 1 - Right cabinet panel (17 7/16" x 23 1/4")
- M. 1 - Door panel (19 1/4" x 23 1/8")
- N. 1 - Bottom panel (20 3/8" x 30 5/8")
- O. 4 - M10x35 Allen screws
- P. 4 - M10 nuts
- Q. 4 - Casters (2 w/ Brake, 2 w/o Brake, Wrench)
- R. 1 - Magnetic catch and metal strip
- S. 2 - Spindles
- T. 1 - Cam lock and key
- U. 1 - Handle
- V. 2 - Handle screws
- W. 6 - 1/2" wood screws

Tools:
 W. 1 - Small M6 Allen wrench
 X. 1 - Large M10 Allen wrench
 Tool Required
 1 - Phillips screw driver

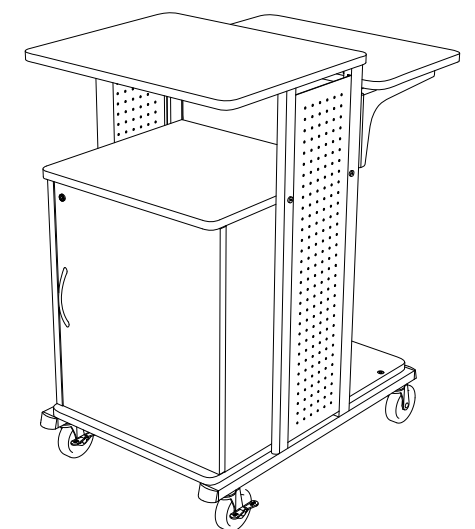
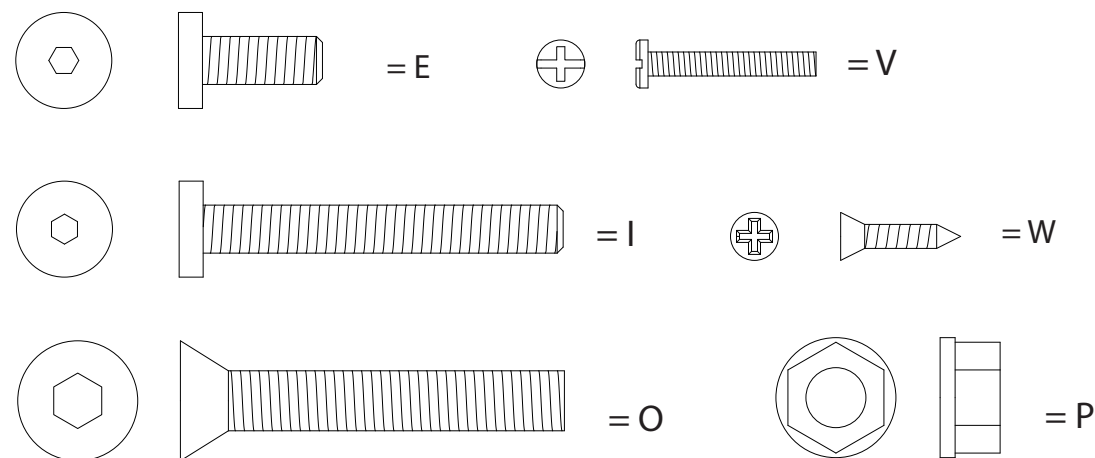

WPS6C Instruction Sheet

Do not completely tighten screws until step 5



H. WILSON

H. Wilson Company
 Address: 2245 Delany Rd.
 Waukegan, IL
 Phone: 800.245.7224
 Fax: 800.245.8224
 Email: sales@hwilson.com
 web: www.hwilson.com

APRIL 2010 - REV00

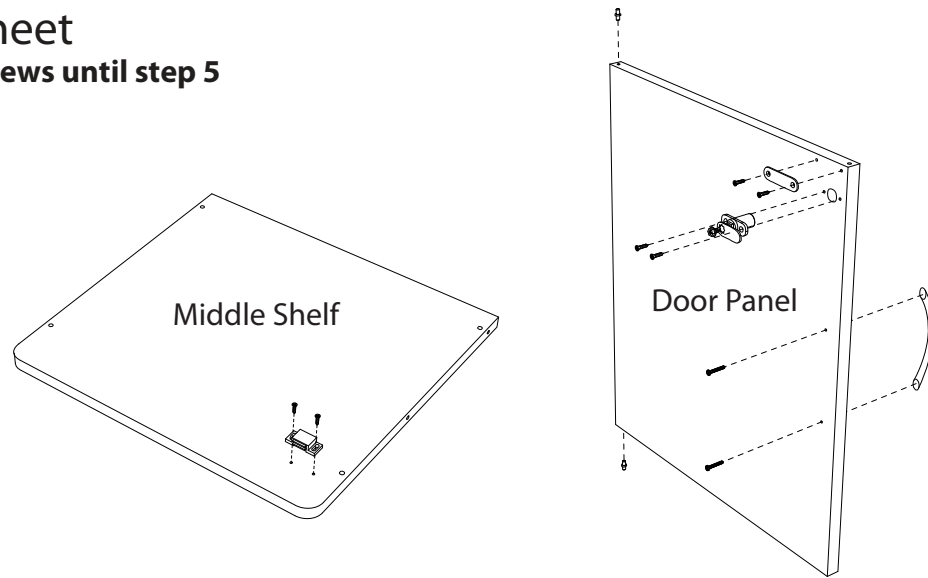

Step 1: Using a Phillips screw driver, install the magnetic catch(R) to the middle shelf(F) with 2 - 1/2" wood screws(W). Install the metal strip(R) and cam lock(T) with 4 - 1/2" wood screws to the door panel(M). Install the handle(U) with the handle screws(V) to the door. Install the spindles(S) to the door.

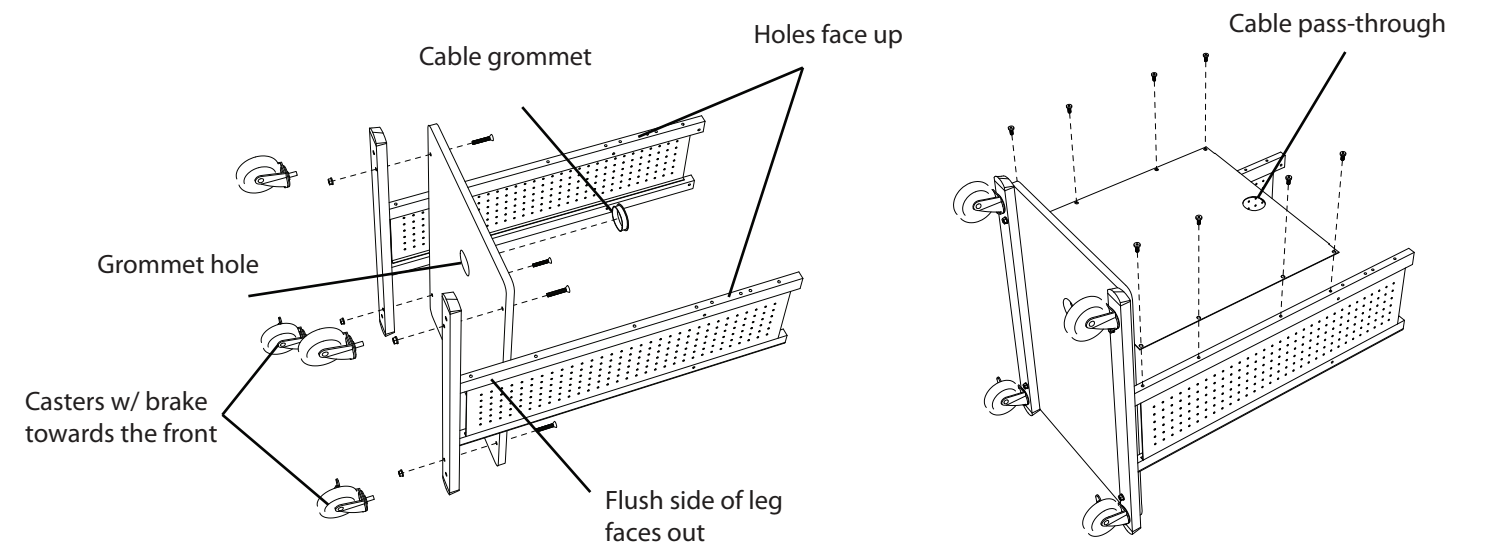

Step 1: Using the large Allen wrench(X), install the base panel(N) to the legs(G) with 4 - M10x35 screws(O) and nuts(P). Install the Casters(Q) and tighten with the caster wrench. Install the cable grommet(K).

Step 2: Using the small Allen wrench, install the metal back panel(H) with the 8 - M6x10 Allen screws(E).

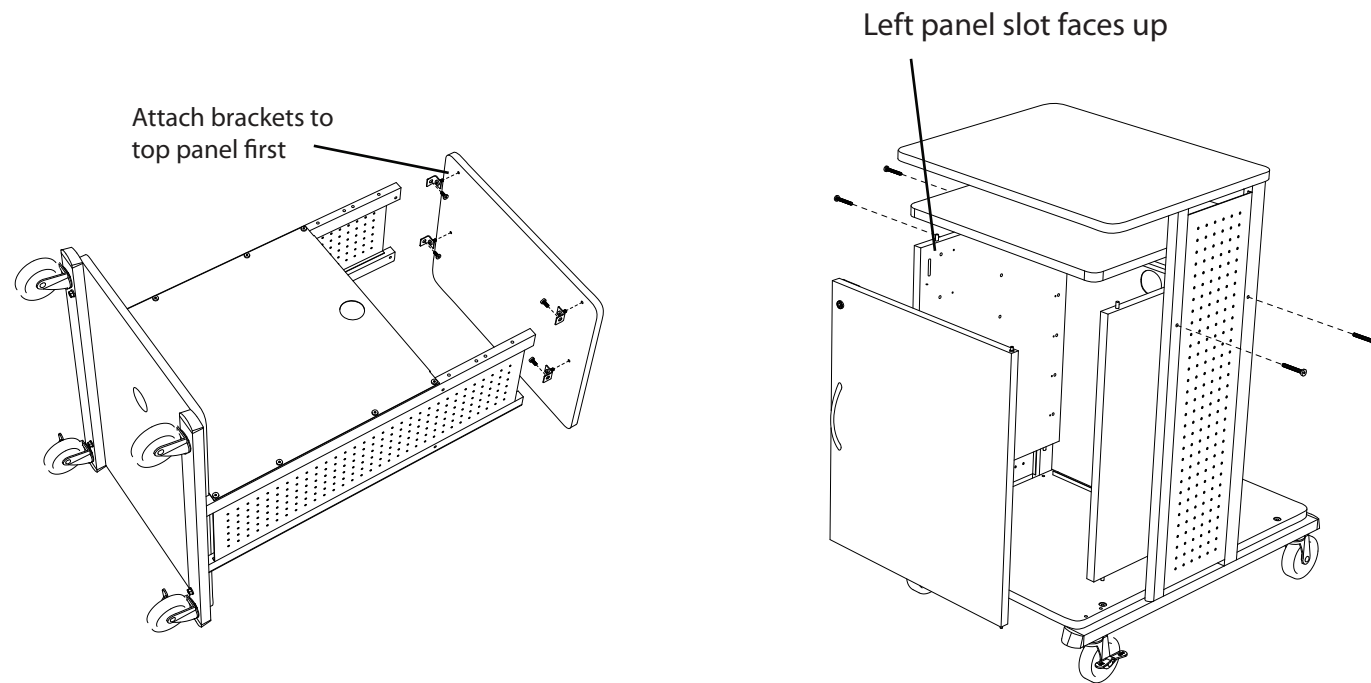

Step 3: Using the small Allen wrench, install the top(A) to the legs with 4 - small L brackets(B) and 8 - M6x10 Allen screws(E).

Step 4: Install the left cabinet(J), right cabinet(L) and door(M) panels. Using the small Allen wrench, install the middle shelf(F) with 4 - M6x35 Allen screws(I).

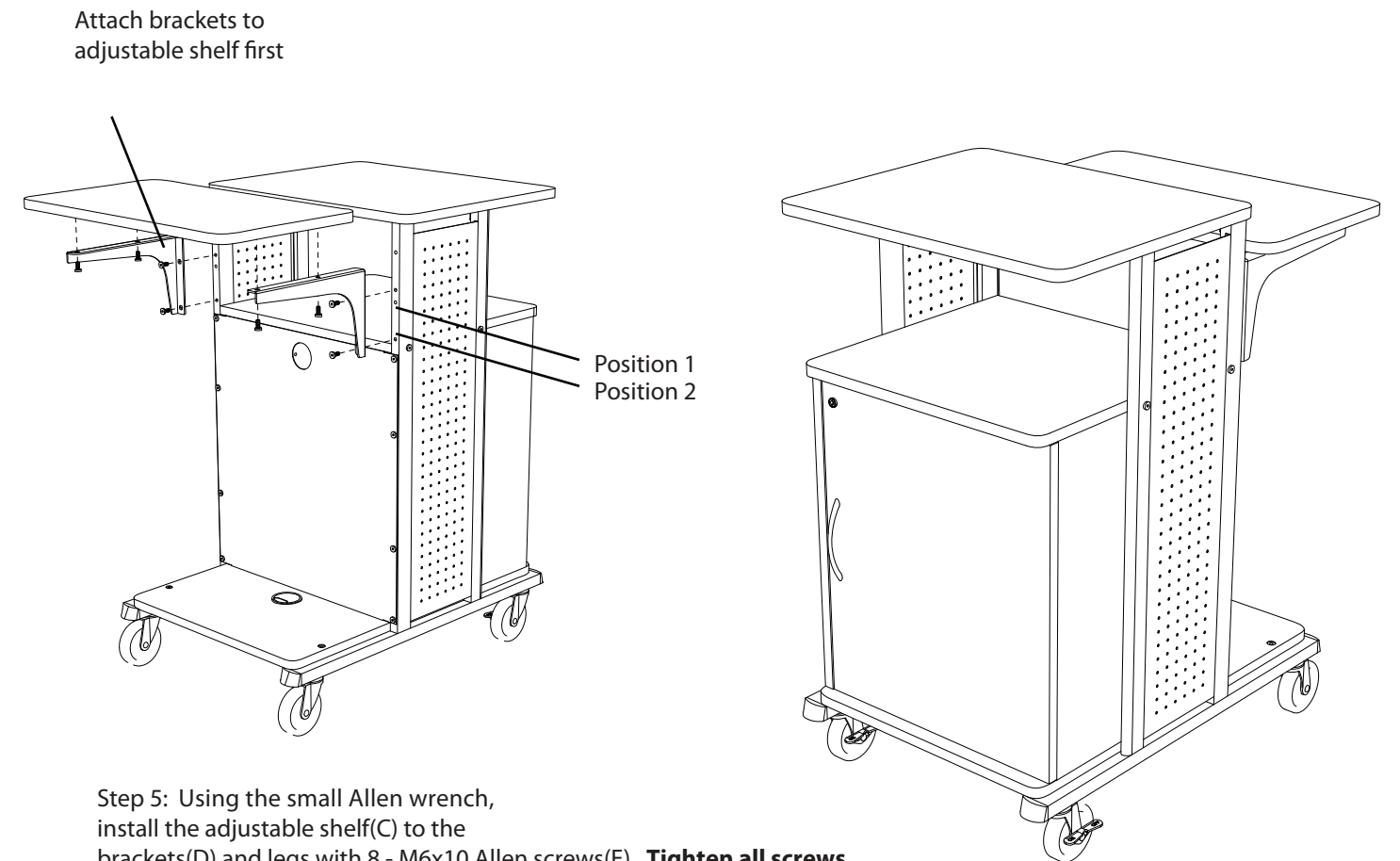

Step 5: Using the small Allen wrench, install the adjustable shelf(C) to the brackets(D) and legs with 8 - M6x10 Allen screws(E). **Tighten all screws.**