



Heavy Duty Presentation Station



Extra large shelves designed for document cameras and A/V equipment. Four gray laminate shelves and a black steel frame.

Tray Measurement:
18½" x 16¼" x 3"

WPS6HDCCE



Second shelf adjusts in 2" increments.

WPS6HDCE

Available with and without lockable storage cabinet.

Optional integrated storage trays. The light gray trays feature a glide & tilt system that allows drawer to be pulled out and held at an angle without falling out.

Optional 3-outlet UL listed electrical assembly with a 15 ft. cord.

A set of heavy duty 4" full swivel ball bearing casters, two with locking brakes.



WPS6HDE

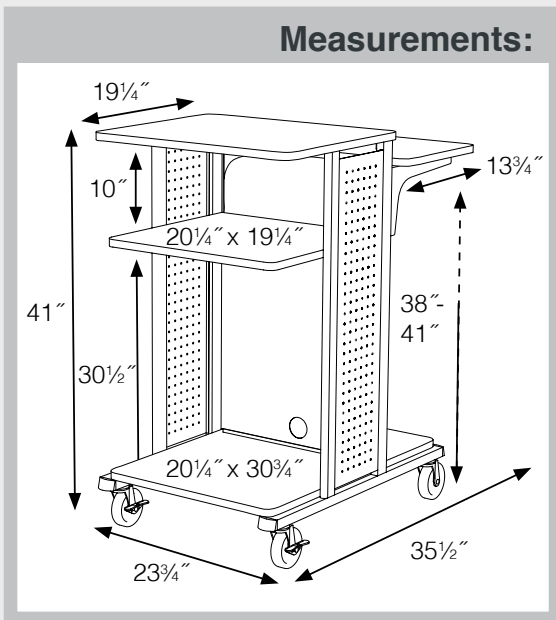

Also available with 7-Outlet electrical assembly or no electrical assembly

41" H x 23¾" W x 35½" D