

Instruction Sheet
Models MTC-20/N, MTC-30/N, MTC-20D/N,
MTC-25D/N and MTC-30D/N



Customer Service Dept
 2245 Delany Rd
 Waukegan, IL 60087
 Ph: 847/244-1800 • 800/323-4656
 Fax: 847/244-1818 • 800/327-1698



MTC-20/N



MTC-30/N

PARTS LIST

- Model MTC20/N**
 1 - Top shelf w/handle & tray
 1 - Set of 25" legs
 1 - Bottom shelf w/caster sockets
 1 - Set of 4" casters (2 w/brake)

- 1 - Top shelf w/handle & tray
 2 - Sets of 11" legs
 1 - Middle shelf w/tray
 1 - Bottom shelf w/caster sockets
 1 - Set of 4" casters (2 w/brake)

- 1 - Rubber mallet
 1 - Slotted screwdriver

Note: Models MTC34F/N and MTC25/N follow general instructions as MTC30/N.

- Model MTC20D/N**
 1 - Top shelf w/handle & notched tray
 1 - Set of 25" legs
 1 - Bottom shelf w/caster sockets
 1 - Set of 4" casters (2 w/brake)
 6 - Sliding dividers

- Models MTC-25D/N & MTC30D/N**
 1 - Top shelf w/handle & notched tray
 2 - Sets of 11" legs
 1 - Middle shelf w/tray
 1 - Bottom shelf w/caster sockets
 1 - Set of 4" casters (2 w/brake)
 6 - Sliding dividers

Tools Required

Model MTC30/N

Your Endura Maintenance Cart does not have the Optional Electrical Assembly and Cable-Track™ Cord Management System, start by closing the electric plug housing in the handle of the top shelf as illustrated below.

Models MTC-20/N & MTC-20D/N

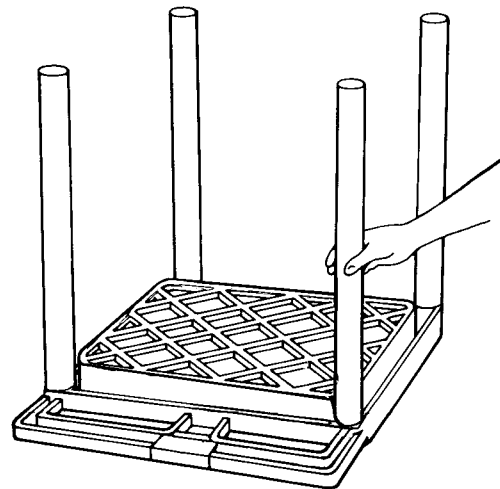

- 1** Lay top shelf (with handle and tray), ribbed side up on a smooth surface. Push all 4 legs onto leg posts.

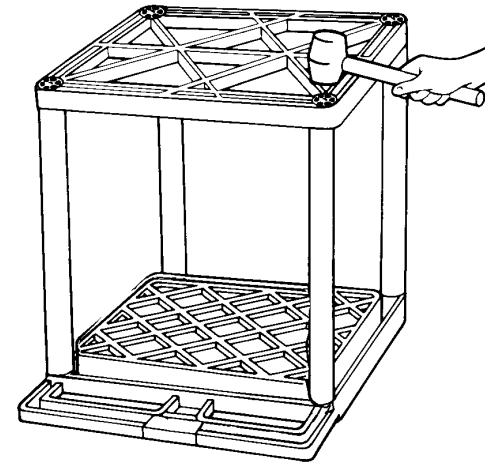

- 2** Position bottom shelf, ribbed side up, over the 4 legs and insert leg posts into legs. Using a rubber mallet, firmly hammer bottom shelf into legs until all four legs are seated (flush) against the surfaces of both shelves.

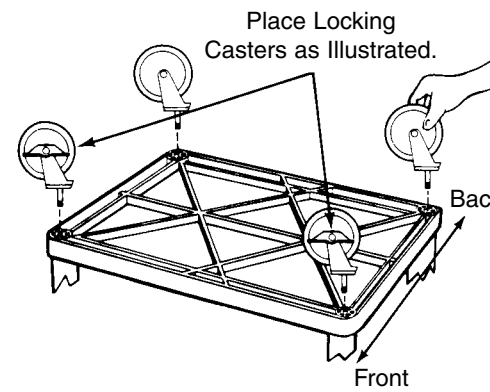

- 3** Push the four casters firmly into the holes in each corner of the bottom shelf. **Important:** casters must be fully seated. Tap firmly with rubber mallet to properly seat casters. Turn your Endura Table right side up.

NOTE: For Models MTC-20D/N, MTC25D/N and MTC-30D/N

Slide 6 dividers into any of the twelve slots provided. It is now ready for use.

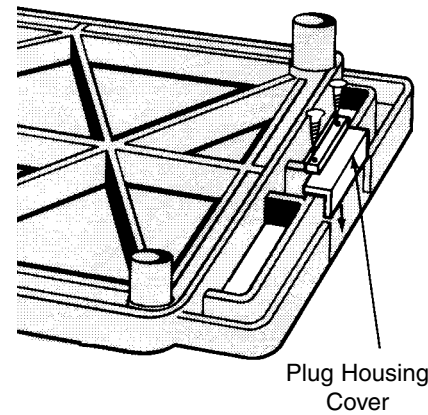
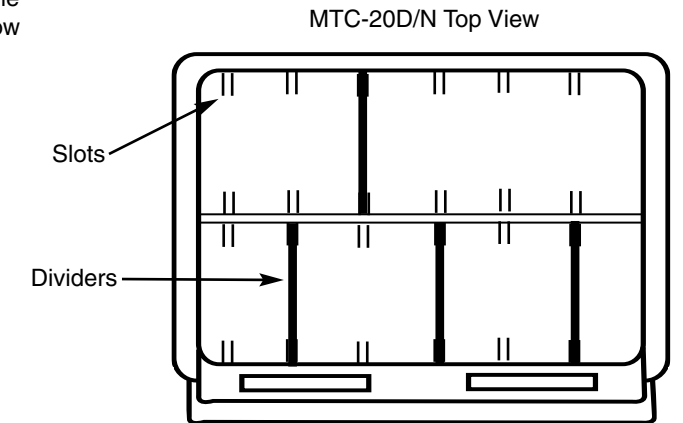

Plug Housing Cover

Models MTC-30/N, MTC-30D/N & MTC-25D/N

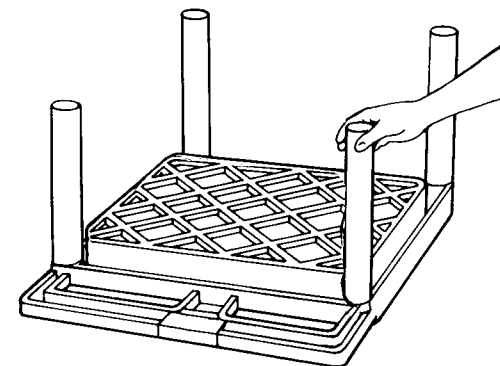

- 1** Lay top shelf (with handle and tray), ribbed side up on a smooth surface. Push all 4 legs onto leg posts.

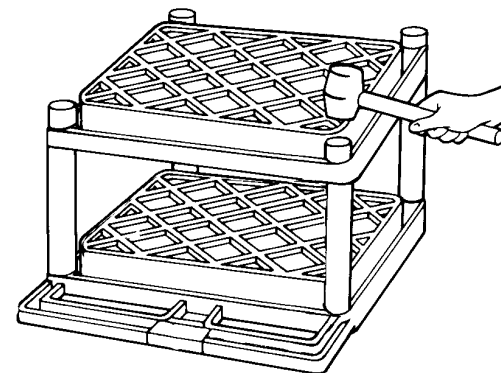

- 2** Position center shelf (with 8 leg posts), ribbed side up, over the 4 legs and insert leg posts into legs. Using a rubber mallet, firmly hammer center shelf into legs until all four legs are seated (flush) against the surfaces of both shelves.

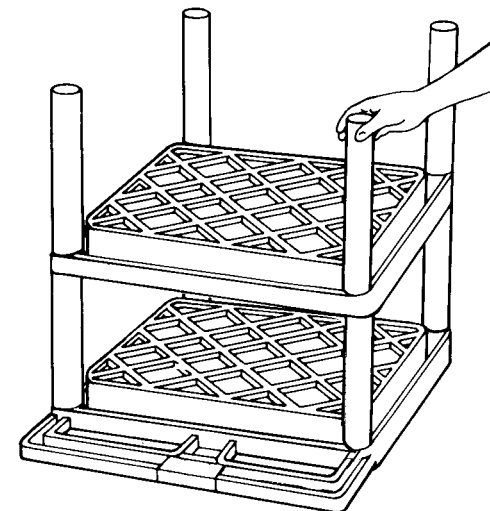

- 3** Push other set of 4 legs into leg posts of second shelf and firmly hammer until properly seated.

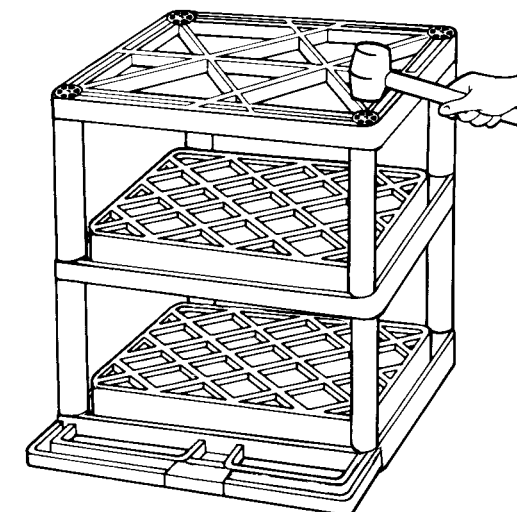

- 4** Position bottom shelf, ribbed side up, over the 4 legs and insert leg posts into legs. Using a rubber mallet, firmly hammer bottom shelf into legs until all four legs are seated (flush) against the surfaces of both shelves.

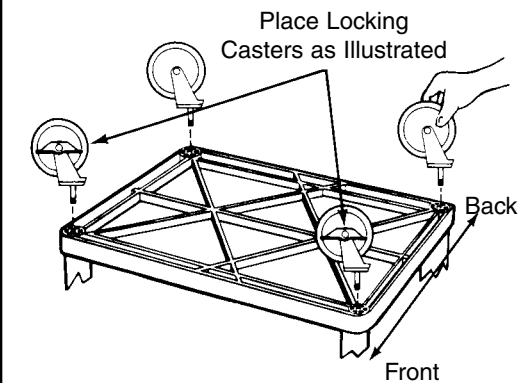

- 5** Push the four casters firmly into the holes in each corner of the bottom shelf. **Important:** casters must be fully seated. Tap firmly with rubber mallet to properly seat casters. Turn your Endura Table right side up.

Instruction Sheet MTCLL/LTLL



Customer service dept.
2245 Delany Rd
Waukegan, IL 60087

Ph: 847/224-1800 • 800/323-4656
Fax: 847/224-1818 • 800/327-1698



MTCLL/LTLL

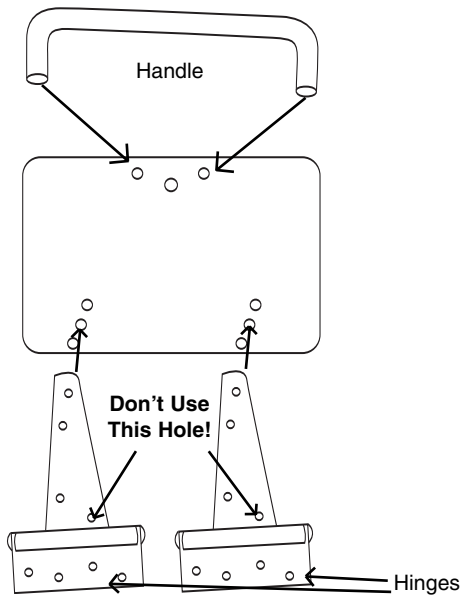

Step 1

Align handle holes to the two predrilled holes on the lid and attach with two screws.

Lid/Lock Assembly

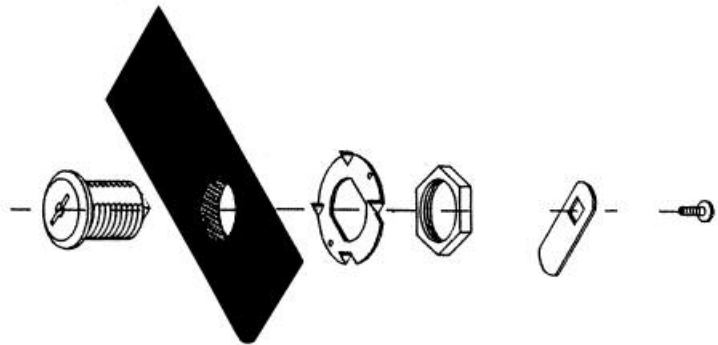

Attach the hinges as shown with six bolts and nuts. The last hole on the hinges won't be used.

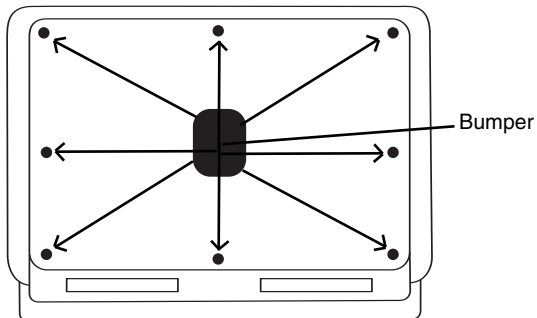

Step 2

Place plastic bumpers as shown in the diagram.

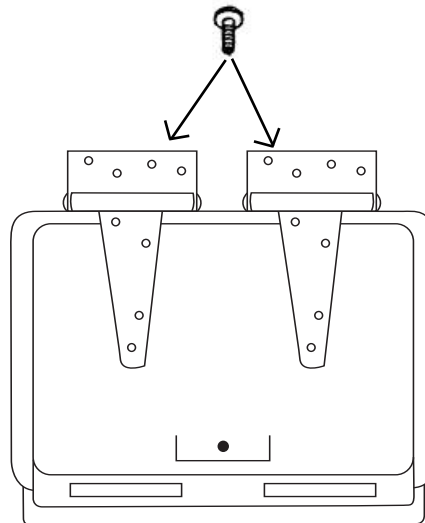

Step 3

Place lid on the top shelf and flip the back part of the hinge down to the back side of the top shelf and insert eight sheet metal screws into the plastic.

PARTS LIST

- 2 - Hinges **0089136**
- 1 - Lid **NB91247**
- 8 - Bumpers **0091121**
- 1 - Hardware pack
- 1 - Lock Assembly **0085132**