

LUXOR | H. WILSON

®

INSTALLATION MANUAL



FLAT PANEL DISPLAY CART LEWTUD & LEWCTUD Series

Models: LE27WTUD, LE27CWTUD, LE40WTUD, LE40CWTUD, LE48WTUD & LE48CWTUD

Phone: 847.244.1800 • 800.323.4656 Fax: 847.244.1818 • 800.327.1698 Address: 2245 Delany Rd. • Waukegan, IL 60087



Thank you for your purchase. The LEWTUD & LEWCTUD Series are totally integrated mount/cart solutions for 32"-50" flat panel displays. To truly appreciate the capabilities and versatility of the flat panel display cart, please read this installation manual completely.

Table of Contents

| | |
|----------------------------------|-------|
| Warning Statements | 2 |
| Part Lists | 3-5 |
| Cart Assembly Instructions | 6-10 |
| Display Instructions | 11-14 |
| Cabinet Pack Instructions | 15 |

Warning Statements

Warning: LUXOR FURNITURE DOES NOT WARRANT AGAINST DAMAGE CAUSED BY THE USE OF ANY LUXOR FURNITURE PRODUCT FOR PURPOSES OTHER THAN THOSE FOR WHICH IT WAS DESIGNED OR DAMAGE CAUSED BY UNAUTHORIZED ATTACHMENTS OR MODIFICATIONS, AND IS NOT RESPONSIBLE FOR ANY DAMAGES, CLAIMS, DEMANDS, SUITS, ACTIONS OR CAUSES OF ACTION OF WHATEVER KIND RESULTING FROM, ARISING OUT OF OR IN ANY MANNER RELATING TO ANY SUCH, ATTACHMENTS OR MODIFICATIONS.

Warning: THE FLOOR SHOULD BE CAPABLE OF SUPPORTING A MINIMUM WEIGHT OF 160 LBS. IF NOT, THE FLOOR MUST BE REINFORCED. THE WEIGHT OF THE FLAT PANEL SHOULD BE NO MORE THAN 160 LBS. PROPER INSTALLATION PROCEDURES BY QUALIFIED PERSONNEL AS OUTLINED IN THE INSTALLATIONS INSTRUCTIONS MUST BE ADHERED TO. FAILURE TO DO SO COULD RESULT IN SERIOUS PERSONAL INJURY.

Warning: SAFETY MEASURES MUST BE PRACTICED AT ALL TIMES DURING THE INSTALLATION OF THIS PRODUCT. USE PROPER SAFETY GEAR AND TOOLS FOR THE INSTALLATION PROCEDURE TO PREVENT PERSONAL INJURY.

Warning: PRIOR TO THE INSTALLATION OF THIS PRODUCT, THE INSTALLATION INSTRUCTIONS SHOULD BE READ AND COMPLETELY UNDERSTOOD. THE INSTALLATION INSTRUCTIONS MUST BE READ TO PREVENT PERSONAL INJURY AND PROPERTY DAMAGE. KEEP THESE INSTALLATION INSTRUCTIONS IN AN EASILY ACCESSIBLE LOCATION FOR FUTURE REFERENCE.

Warning: DO NOT INSTALL ON A STRUCTURE THAT IS PRONE TO VIBRATION, MOVEMENT OR CHANCE OF IMPACT. FAILURE TO DO SO COULD RESULT IN DAMAGE TO THE DISPLAY AND/OR DAMAGE TO THE MOUNTING SURFACE.

Warning: DO NOT INSTALL NEAR HEATER, FIREPLACE, DIRECT SUNLIGHT, AIR CONDITIONING OR ANY OTHER SOURCE OF DIRECT HEAT ENERGY. FAILURE TO DO SO MAY RESULT IN DAMAGE TO THE DISPLAY AND COULD INCREASE THE RISK OF FIRE.

Questions/Concerns: CALL CUSTOMER SUPPORT @ 847.244.1800 OR 800.323.4656

Part List:

NOTE: Please familiarize yourself with all components contained herein.

NOTE: Please review all WARNING and CAUTION statements (see Page 2) before beginning the installation of the Flat Panel Display Cart.

1 - Top Shelf



1 - Middle Shelf *



1 - Bottom Shelf

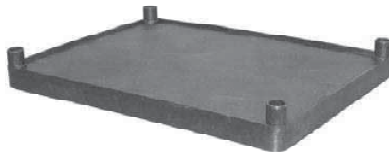

4 - 17.75" Legs



4 - Short/Long Legs *



4 - Casters (2 Locking, 2 Non Locking)



1 - Cabinet Pack ***

1 - Power Cord Storage Arm **



1 - Power Cord



2 - "E" Clips **



1 - Base Block



1 - Sandwich Plate



2 - Chrome Tubes



2 - Mounting Brackets



2 - Vertical Brackets



* - Not Included with 2 Shelf Units, Length varies depending on model
 ** - Not Included with 2 Shelf Cabinet Pack Units
 *** - Not All Units Include a Cabinet Pack

Part List Continued:

NOTE: Please familiarize yourself with all components contained herein.

NOTE: Please review all WARNING and CAUTION statements (see Page 2) before beginning the installation of the Flat Panel Display Cart.

1 - Electric Hardware Bag

- A. 1 - Grommet Pass-Through
- B. 1 - Power Cord Retainer Clip
- C. 4 - Cord Management Ties
- D. 4 - Slotted Self Tapping Screws

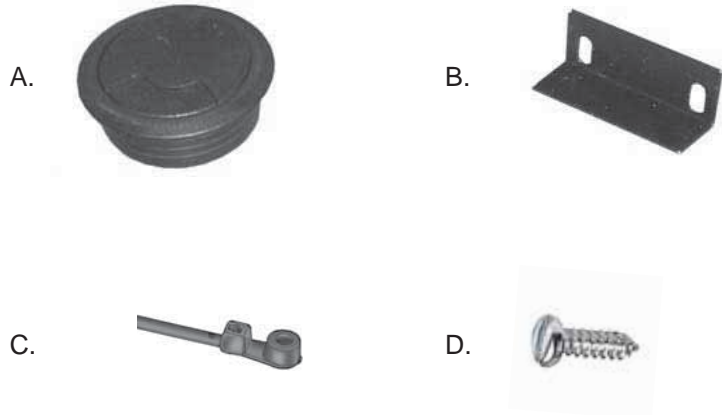

1 - Sandwich Plate Hardware Bag

- E. 1 - Allen Wrench
- F. 6 - M8 Set Screws
- G. 6 - M5 Nuts
- H. 6 - M5 Lock Washers
- I. 6 - M5 x 55 mm Phillips Head Screws
- J. 5 - M5 x 12 mm Hex Head Screw
- K. 5 - M5 Washers

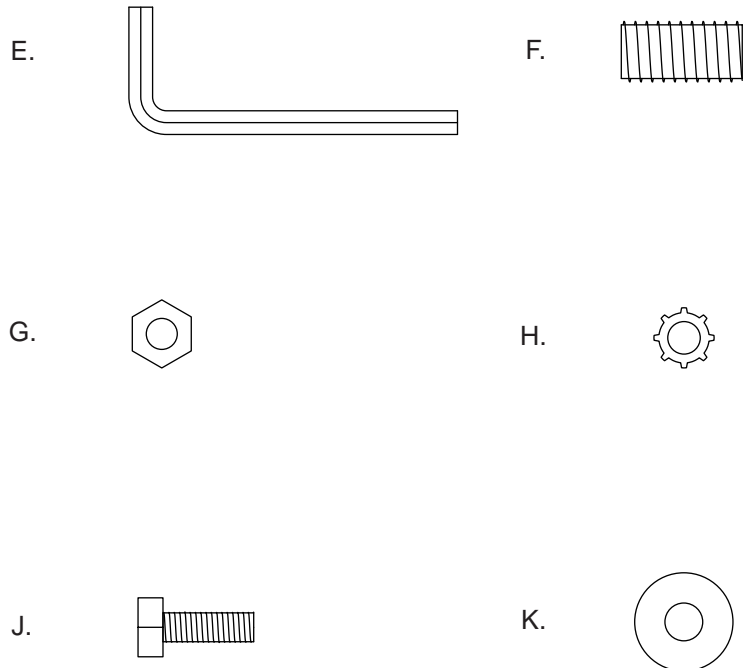

Part List Continued:

NOTE: Please familiarize yourself with all components contained herein.

NOTE: Please review all WARNING and CAUTION statements (see Page 2) before beginning the installation of the Flat Panel Display Cart.

1 - Display Connection Hardware Bag

Section 1

- L. 4 - M4 x 12 mm Screws
- M. 4 - M4 x 30 mm Screws
- N. 4 - M4 Lock Washers

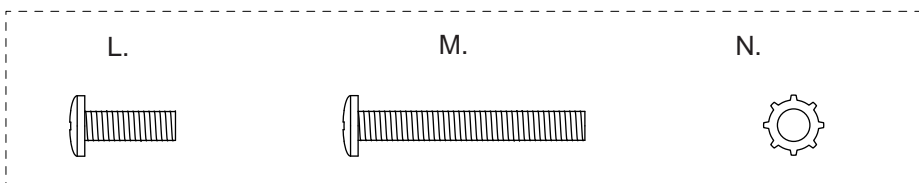

Section 2

- O. 4 - M5 x 12 mm Screws
- P. 4 - M5 x 30 mm Screws
- Q. 4 - M5 Lock Washers

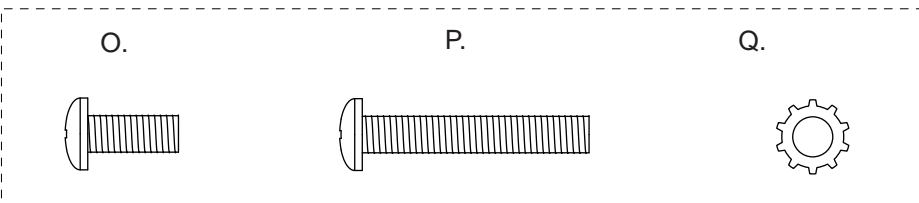

Section 3

- R. 4 - M6 x 12 mm Screws
- S. 4 - M6 x 35 mm Screws
- T. 4 - M6 Lock Washers
- U. 4 - M8 x 16 mm Screws
- V. 4 - M8 x 40 mm Screws
- W. 4 - M8 Washers

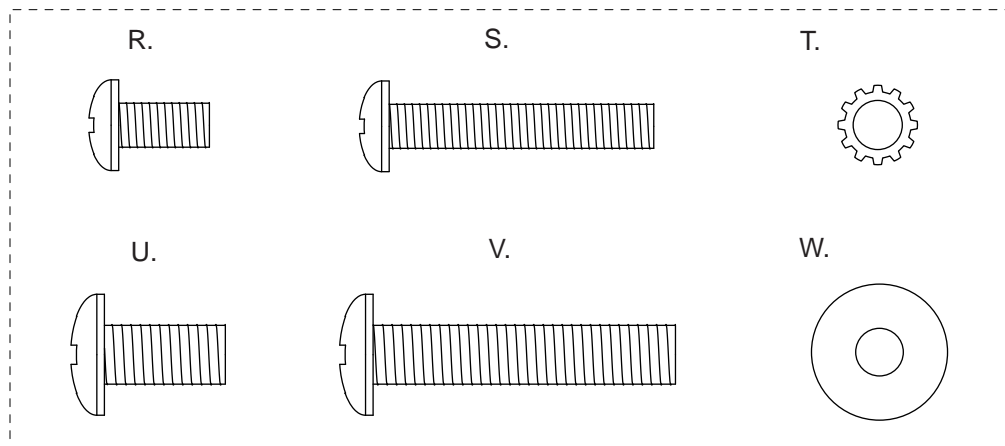

Section 4

- X. 4 - Large Nylon Inserts
- Y. 4 - Small Nylon Inserts
- Z. 4 - Washers

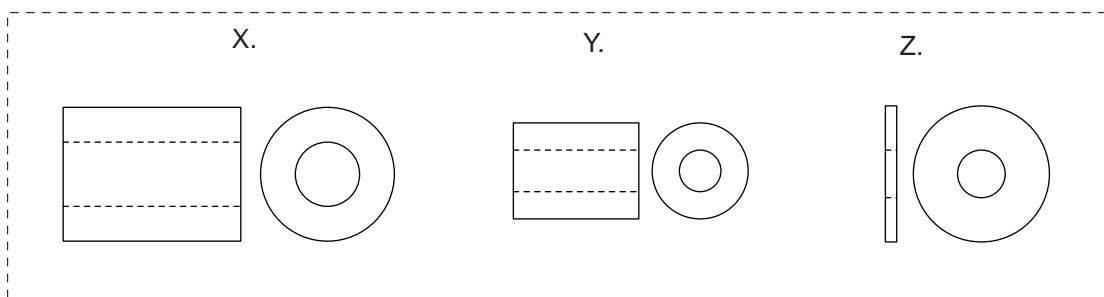

Tools Needed

- 1 - Phillips Screw Driver
- 1 - Flat Tip Screw Driver
- 1 - Rubber Mallet
- 1 - 5/16 or 8 mm Wrench

- 1 - Soft Material/ Blanket
- 1 - 1/8" Diameter x 3"+ Length Thread Depth Indicator
- 1 - Pencil (Marking Thread Depth Indicator)
- 1 - Ruler or Tape Measure

LEWTUD & LEWCTUD Assembly Instructions

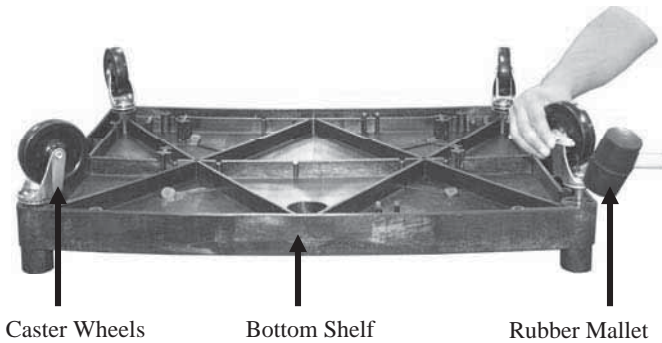

Step 1. Push the four casters firmly into the holes in each corner of the bottom shelf.

Important: Casters must be fully seated. Tap firmly with rubber mallet to properly seat casters.

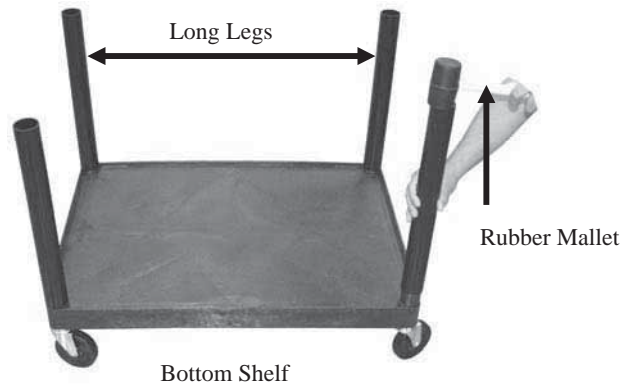

Step 2. Insert the 4 long legs into each corner. Using the rubber mallet, firmly tap each leg unit it is seated securely into position.

NOTE: If you have a cabinet pack, go to page 15 and follow the cabinet pack instructions.

NOTE: If you have a 2 shelf unit continue to step 5.

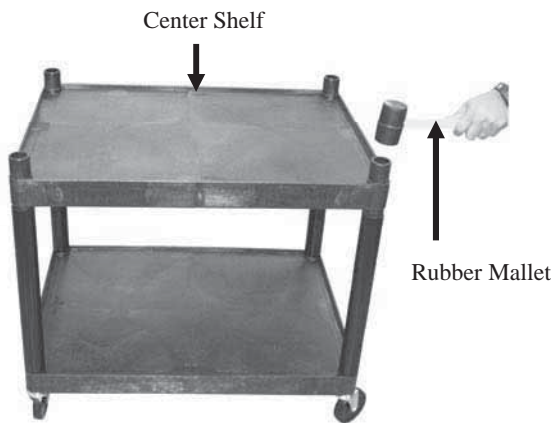

Step 3. Position the center shelf over the long legs and insert each mounting post into each leg. Using a rubber mallet, firmly hammer center shelf into legs until all four legs are seated (flush) against the surfaces of both shelves.

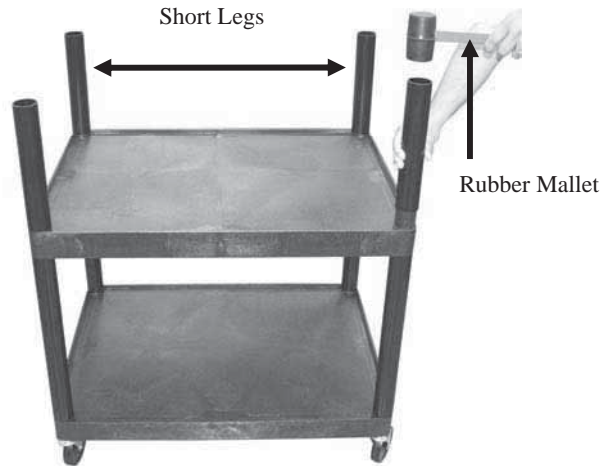

Step 4. Push remaining 4 short legs onto leg posts of center shelf. Tap firmly into place using the rubber mallet.

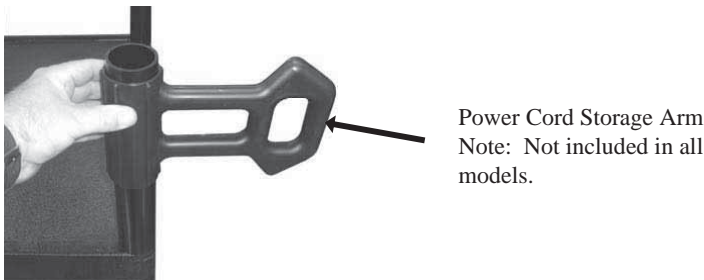

Step 5. Before installing the top shelf, slide the power cord storage arm over the short leg **on the handle side**. The power cord storage arm will allow the user to easily store the power cord while allowing easy extraction when the cord is needed.

Electrical Assembly and Cable-Track Management System

Your Flat Panel Display Cart incorporates the Cable-Track™ Cord Management System. This exclusive feature manages electrical cords, keeping them safely out of the way. This system includes a 3-outlet, 15 foot surge suppressing electric assembly (U.L. and C.S.A. listed) which is built into the safety handle. Please review these instructions carefully to maximize the added safety provided by Luxor's Cable-Track™ Cord Management System.

Parts List

- 1 - Surge protected power cord (A.)
- 1 - Power cord retainer clip (B.)
- 4 - Sheet metal screws (D.)
- 2 - "E"-clips
- 4 - Cord management ties (C.)

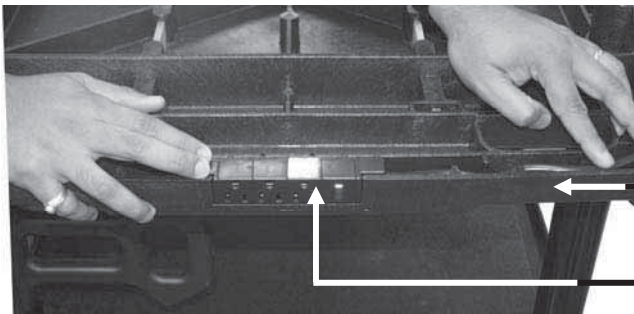

Handle Plug Housing

Power Strip

Step 6. Firmly seat the 3-plug electric assembly unit into the handle plug housing (the top shelf of the cart will need to be turned over in order to access the underside of the handle).

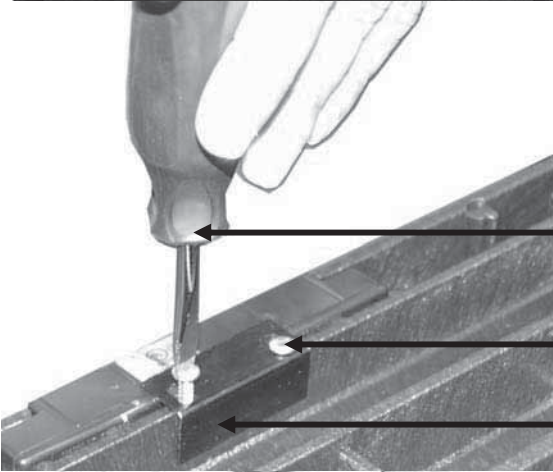

Screwdriver

Sheet Metal Screw

Power Strip Retaining Bracket

Step 7. To secure the power strip, use the power strip retaining bracket and two (2) sheet metal screws and attach using a flat tip screwdriver.

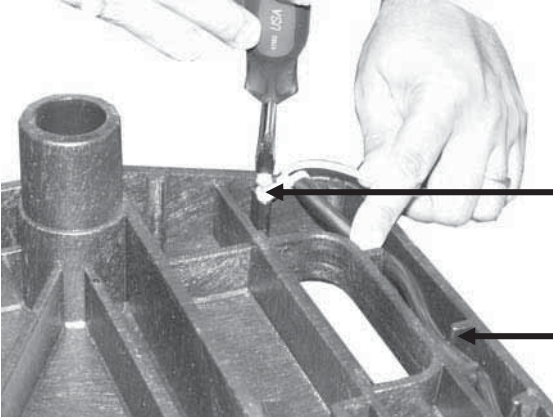

Cord Management Tie

Cord Retaining Track

Step 8. After the power strip has been mounted, route the power cord through the cord retaining track.

Step 9. Attach the cord management tie into the starter holes using a sheet metal screw. Cut off any excess.

Step 10. Secure the power cord using the cord management tie.

Base Mount Assembly and Installation

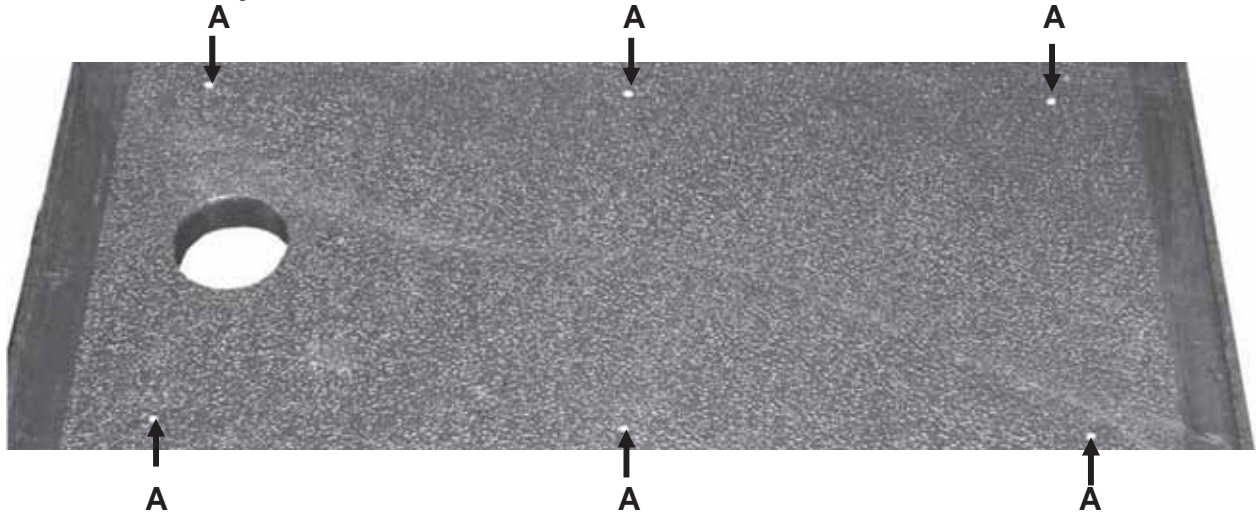

Step 11. Determine where the mounting points are on the top shelf of the Luxor Cart (Arrows).
A – Sandwich Mounting Plate Mounting Points.

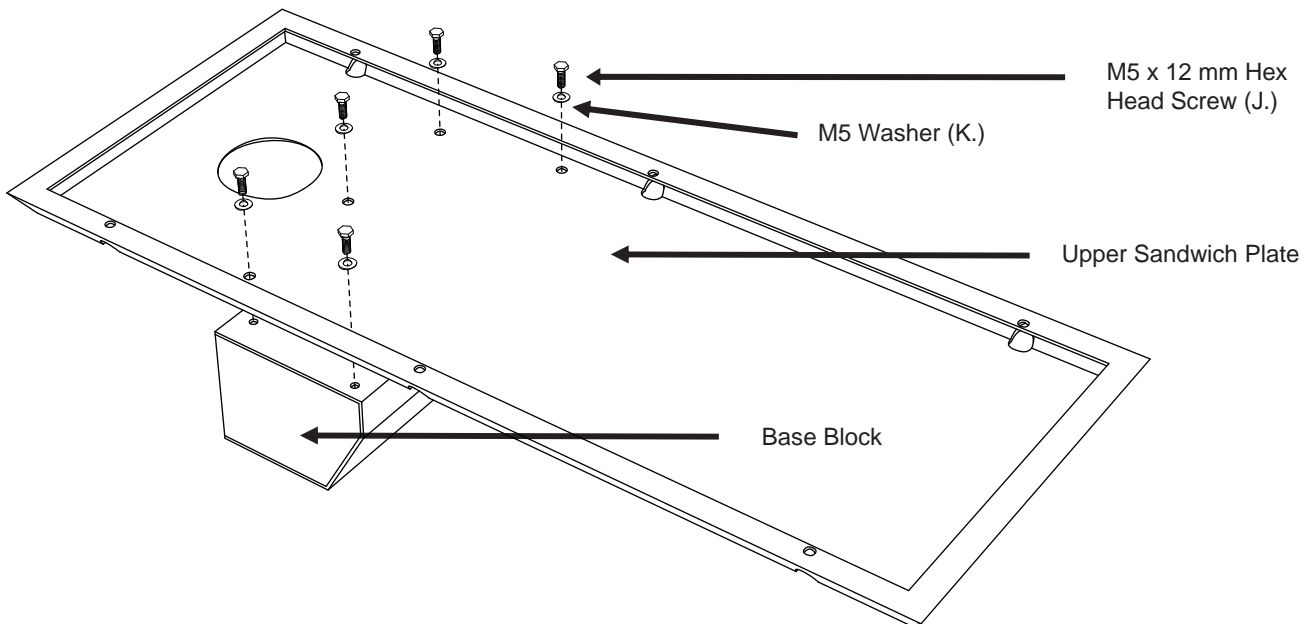

Step 12. After locating the mounting points for the base block, it is now time to attach the base block to the upper sandwich plate.

Step 13. Line up the mounting holes on the upper sandwich plate with the mounting holes on the base block.

Step 14. Once the holes are lined up, use 5 - M5 x 12mm Hex head screws (J.), and the 5 - M5 Washers (K.) to attach the two units together. Tighten them with a 8 mm or 5/16" wrench.

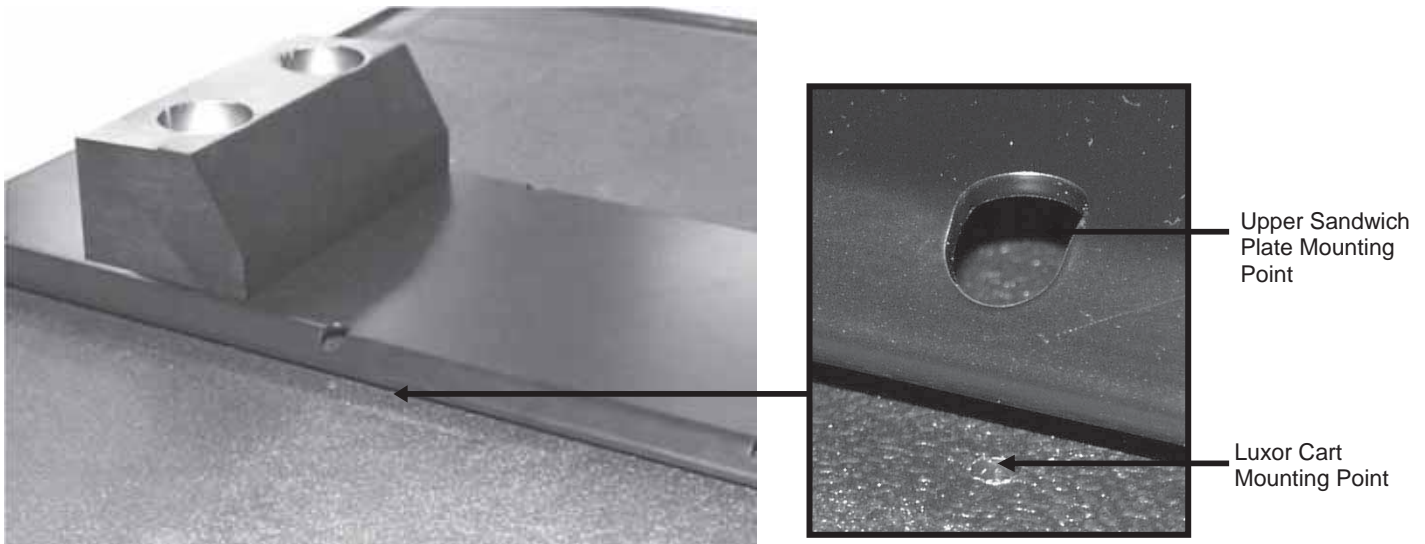

Step 15. Place the upper sandwich plate flat on the top shelf of the Luxor Cart. Line up the mounting holes that are located on the upper sandwich plate with the mounting holes that are located on the top shelf.

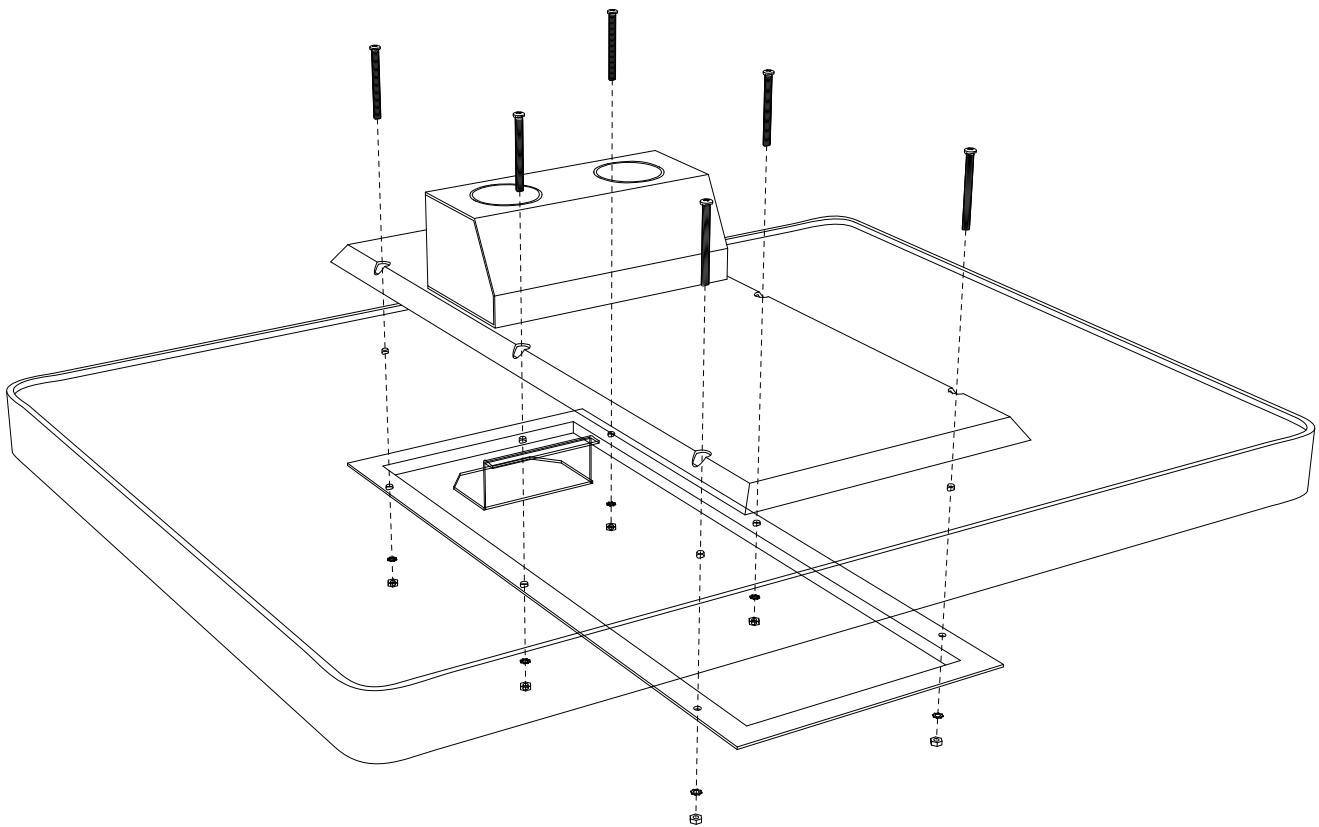

Step 16. **NOTE:** At this time, have an assistant hold the lower sandwich plate in place while the screws are being threaded into place. Insert 6 - M5 x 55 mm Phillips screws (I.) into the upper sandwich plate. With the help of an assistant, align the bottom sandwich plate to the top plate, and thread the lock washer (H.) and Nut (G.) onto the screw. With a 8 mm or 5/16 wrench and the phillips screwdriver, tighten the plates together.

NOTE: The order from top to bottom: M5 x 55mm screw, upper plate, top shelf, lower plate, lock washer and nut.

Final Assembly

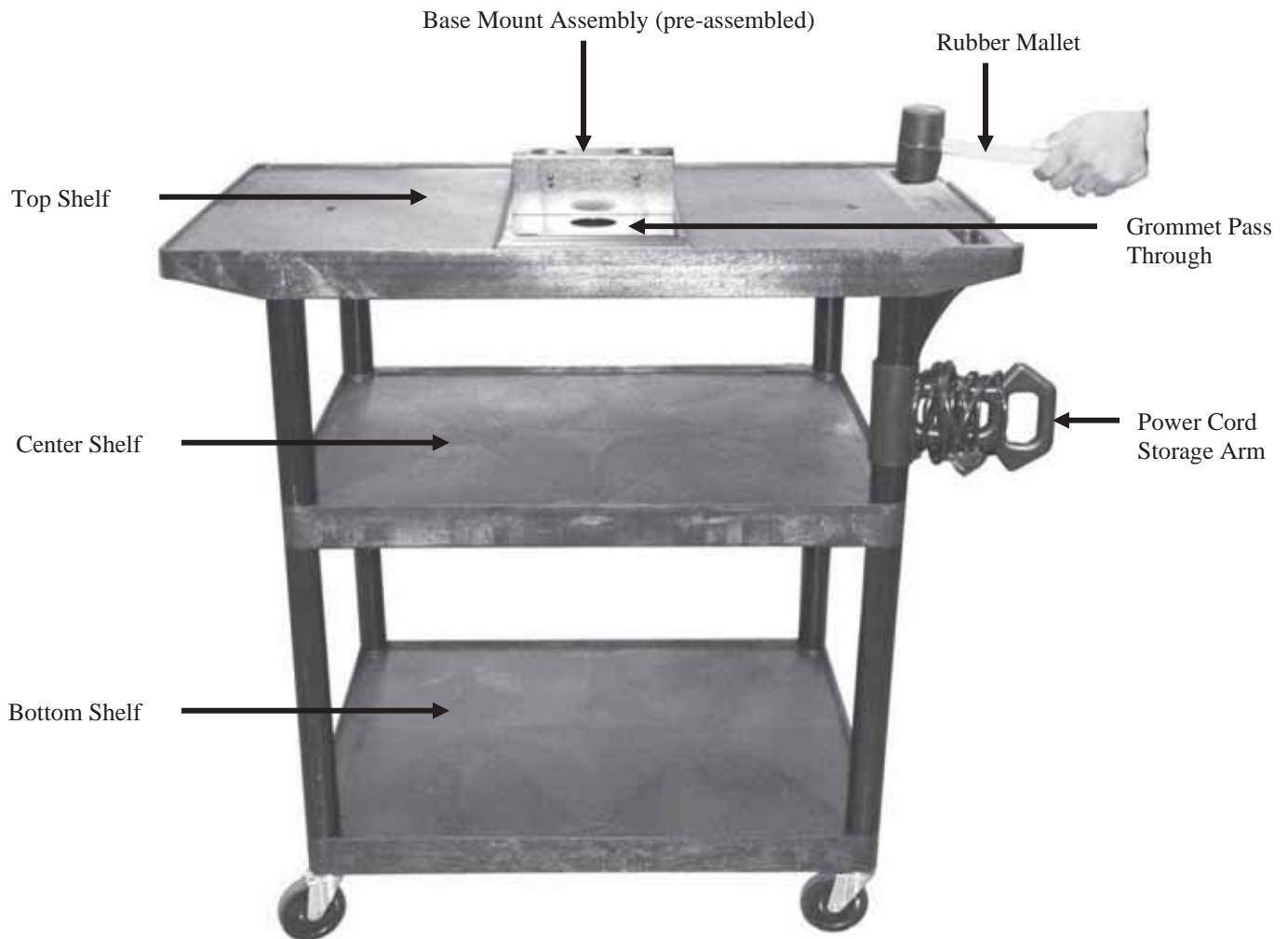

Step 17. Place the top shelf over the four (4) short legs that are attached to the center shelf.

Step 18. Once the short legs are lined up with the mounting posts of the top shelf, tap the top shelf firmly onto the short legs using the supplied rubber mallet. This will complete the first part of the assembly.

Step 19. Place the grommet pass through into the hole located behind the base block.

Thread Depth Indicator

1. Insert the thread depth indicator through the thread inserts found on the back of the flat panel display to make sure the inserts measure the same full depth and mark it with a pencil (see below).
2. Locate the correct diameter screw for the thread insert from the display connection hardware bag. Compare your markings to the screws (supplied).
3. If your selected screw is longer than the marking on the thread depth indicator, **DO NOT USE** this screw.
4. The screw length must not bypass the marking. Select another screw size, until you find one that comes closest to your mark without going past.

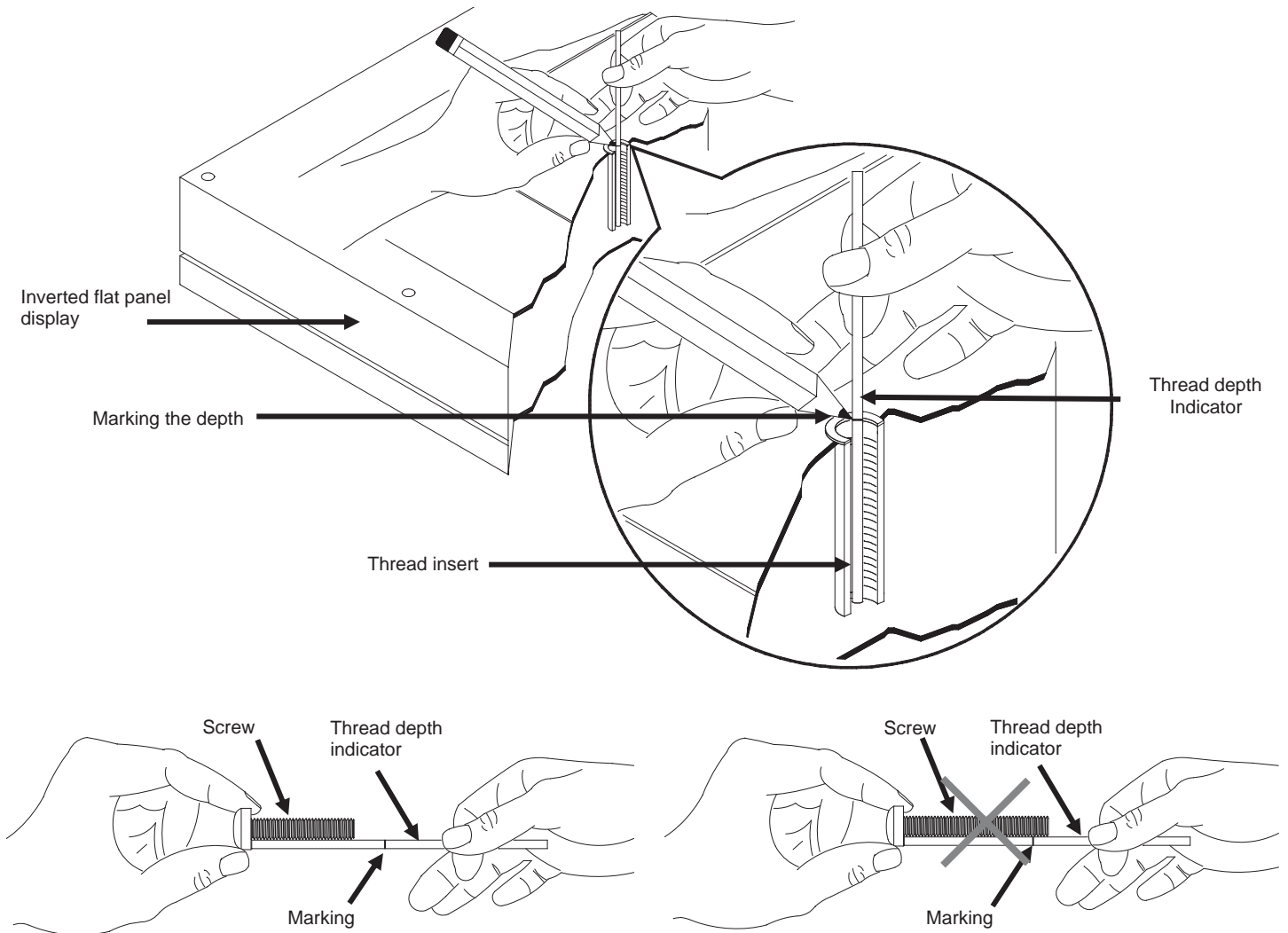

Stand Assembly

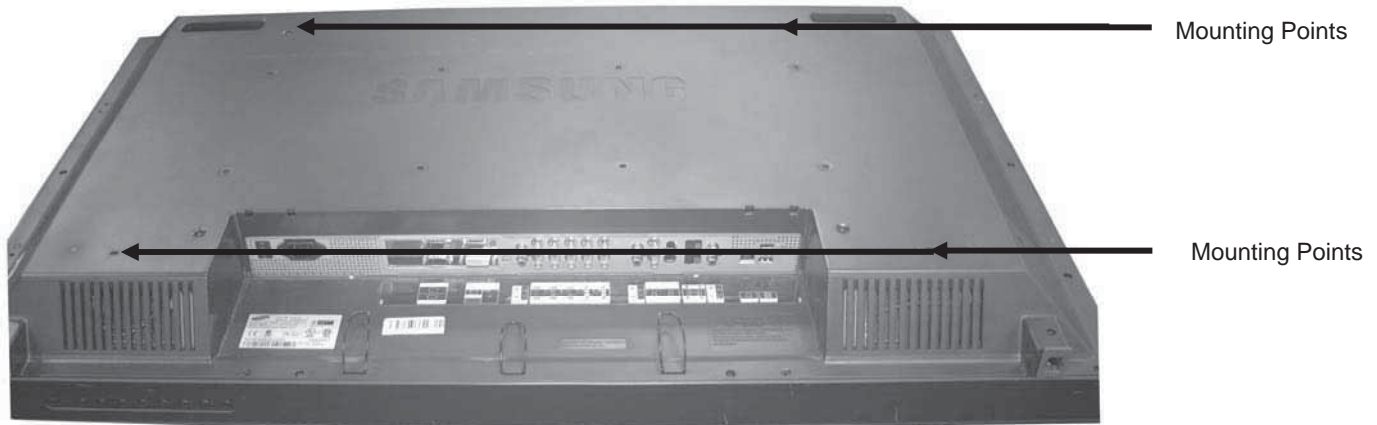

Step 21. Place the display on a soft and flat surface.

Step 22. Locate the mounting points that are on the back of the display.

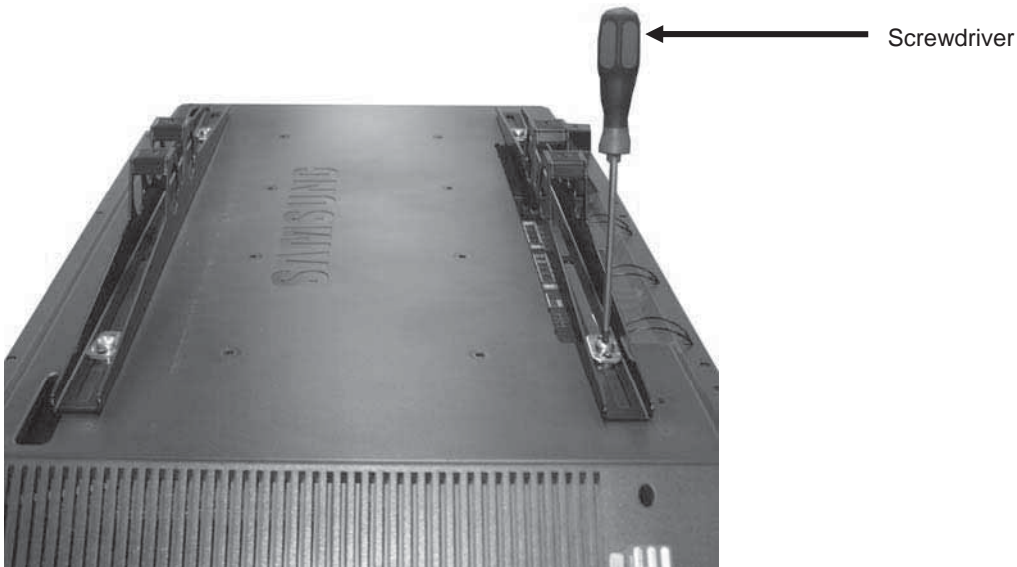

Step 23. Place the mounting brackets over the mounting points.

NOTE: Please refer to page 5 to determine which mounting screws and spacers (if applicable) will be used.

Step 24. Select the appropriate hardware and attach the mounting brackets to the display using the mounting hardware and respective lock washer.

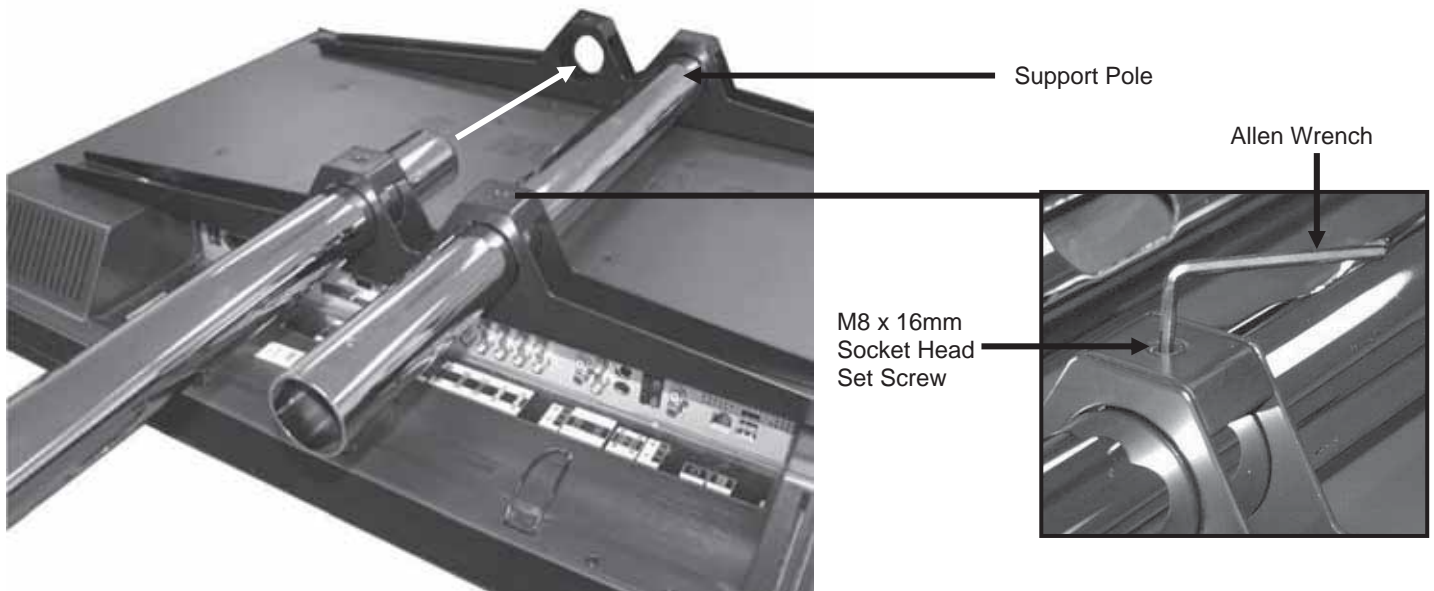

Step 25. Slide each support pole into the mounting bracket.

Step 26. Make sure the support poles are even (see **NOTE:** below), and then tighten the M8 x 16 set screw with the Allen wrench (supplied).

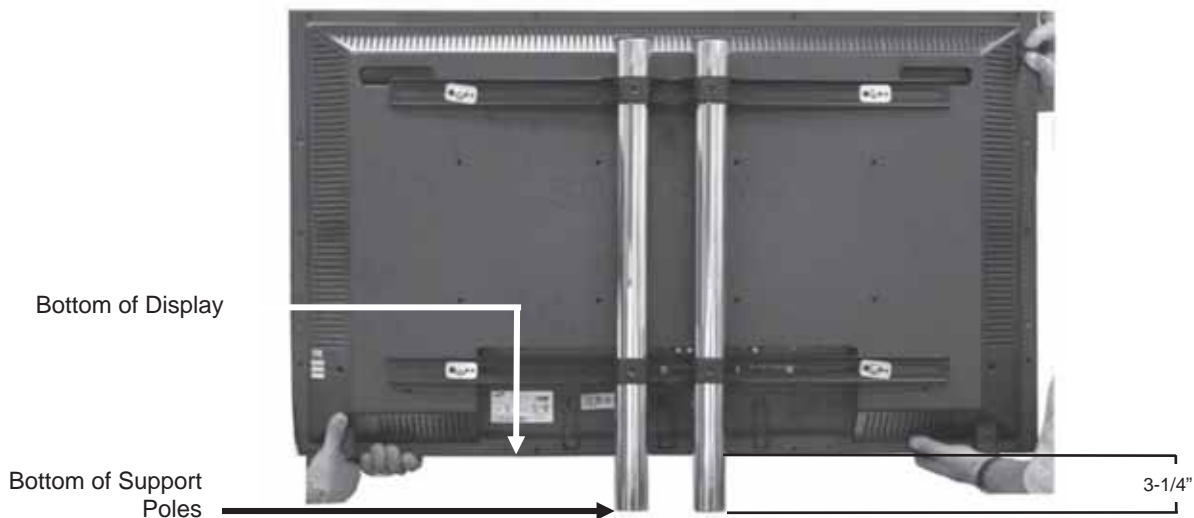

NOTE: Before tightening the M8 x 16mm socket head screws and placing the display assembly into the base mounting block, make sure that the measurement from the bottom of the support poles to the bottom of the display measures 3-1/4". This measurement will allow for correct and even spacing once the display assembly is placed into the base block.

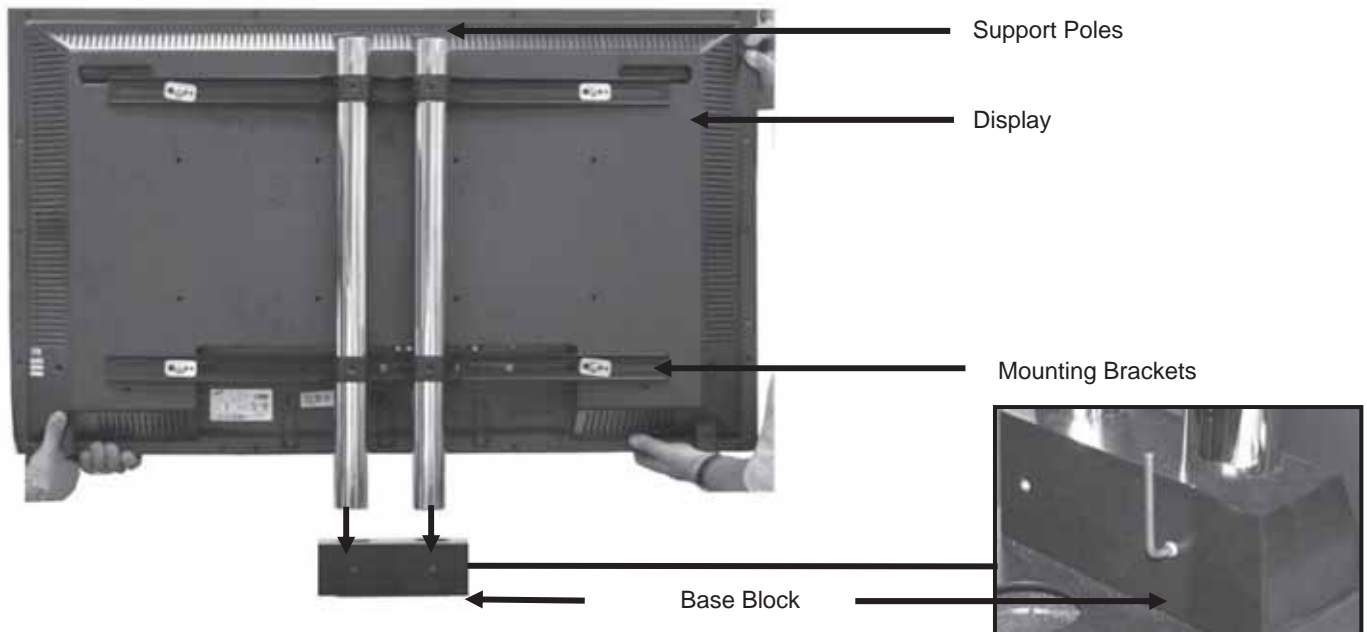

TWO PEOPLE WILL BE NEEDED FOR THE FOLLOWING STEPS.

- Step 27.** After the assembly has been put together, make sure all the hardware is tight.
- Step 28.** Two people should carefully lift the assembly and place the bottom of the support poles into the base block.
- Step 29.** Once the support poles are seated, tighten the M8 x 16mm socket head set screws using the Allen wrench (supplied).

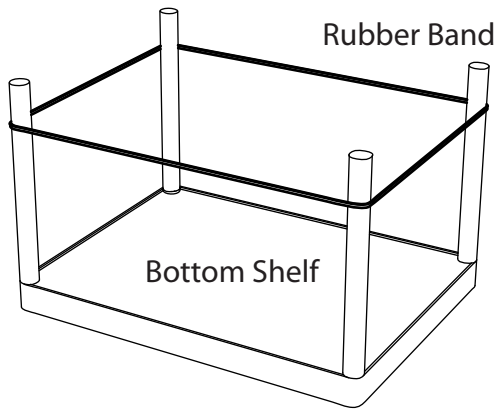

1. Place the included rubber band around the legs.

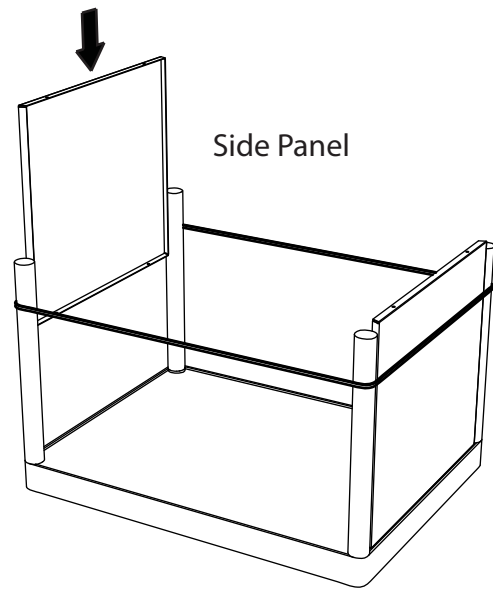

2. Insert the side panels.

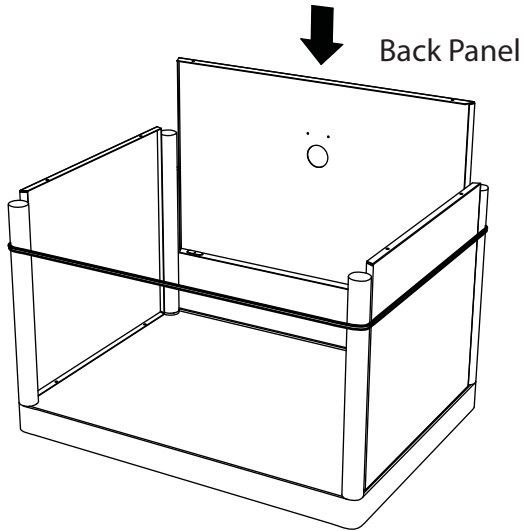

3. Insert the back panel.

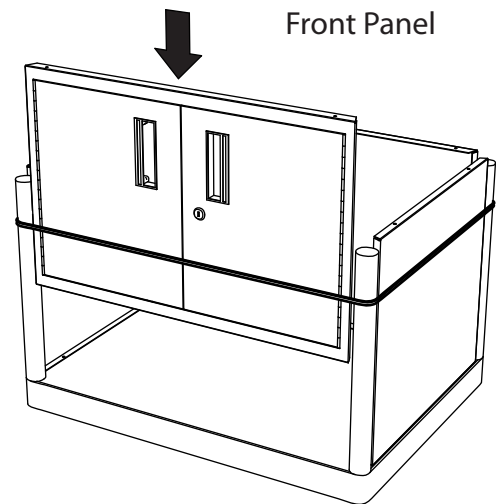

4. Insert the front panel.

NOTE: If you have a 2 shelf unit go back to Step 6 (page 7).

NOTE: If you have a 3 shelf unit go back to Step 3 (page 6).



LE27WTUD



LE40WTUD



LE48WTUD



LE27CWTUD



LE40CWTUD



LE48CWTUD