

SAFETY RULES  
MODEL KD-440  
ELECTRIC SHEAR



The KD-440 has a  
DOUBLE INSULATED  
power unit equipped with a  
2 wire cord and  
2 prong plug



# Component Motor Unit Model 253-59

Used on KD-440, KD-441, KD-442, KD-493 and KD-495 Shears  
 KS-423, KS-424, KS-426 and KSV-432 Saws

## PARTS LIST

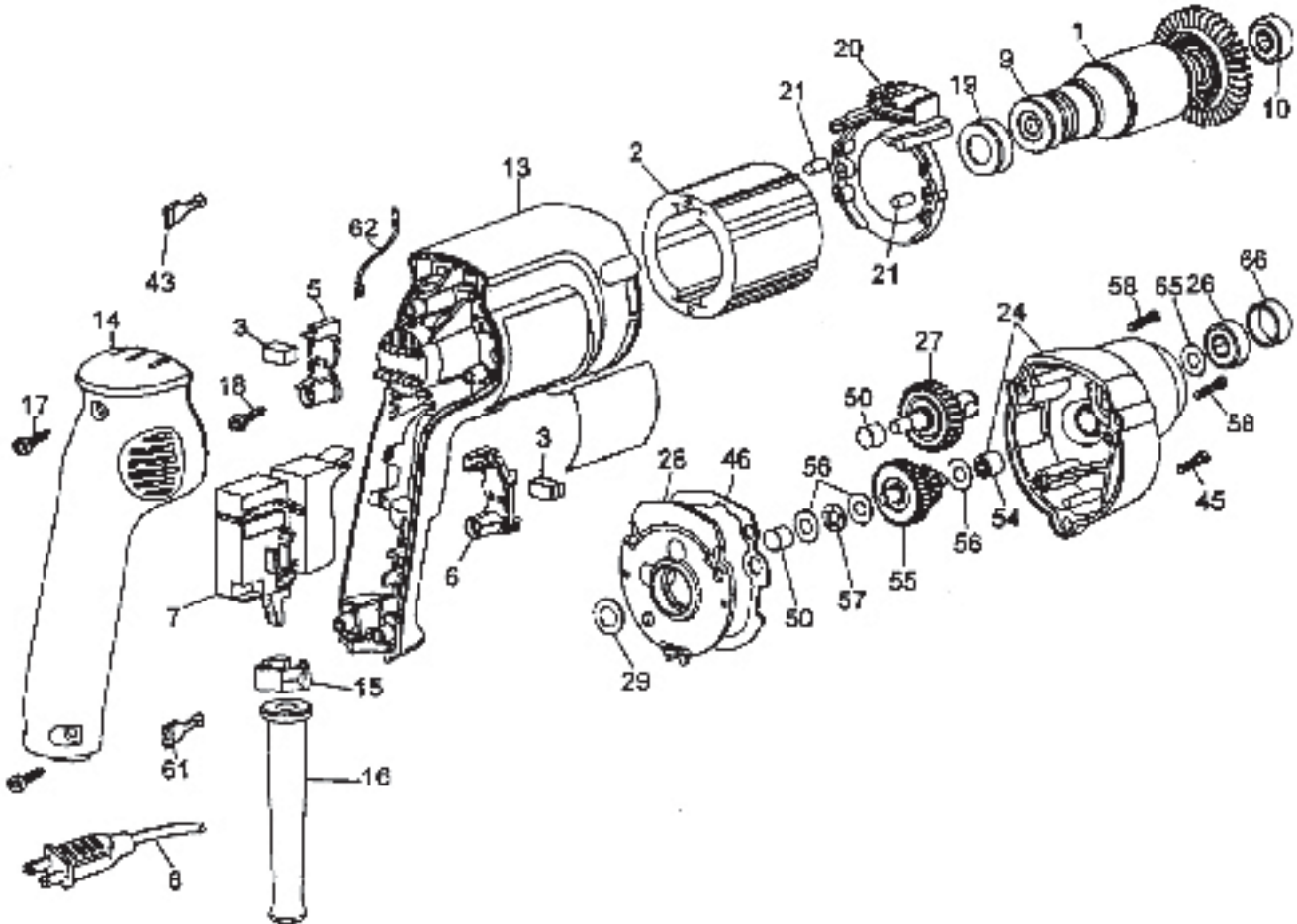

ITEM NO.	PART NO.	DESCRIPTION	REQ'D TOOL	ITEM NO.	PART NO.	DESCRIPTION	REQ'D TOOL
1	382299-01	Armature & Fan (6 Teeth)	1	*54	93129-00	Needle Bearing	1
2	176883-00	Field	1	55	176731-00	Pinion & Gear (15/37 teeth)	1
3	176846-02	Brush	2	56	176732-00	Thrust Washer	3
5	176801-02	Left Brush Holder (gray)	1	57	143079-00	Thrust Washer	1
6	176800-02	Right Brush Holder (black)	1	*58	330019-16	Screw	2
7	176830-39	Switch	1	61	136086-08	Terminal	2
*8	330072-98	Cord & Plug (18-2SJ)	1	62	176860-00	Lead	1
*9	176950-00	Ball Bearing	1	65	449892-00	Washer	1
*10	176950-00	Ball Bearing	1	66	449368-00	Bearing Cap	1
13	396969-09	Field Case	1				
14	176899-02	Handle Cover	1				
*15	176829-00	Cord Clamp	1				
16	330005-01	Cord Protector	1				
*17	330019-13	Screw	3				
*18	176951-00	Screw	2				
*19	389824-00	Cup	1				
20	176811-01	Baffle	1				
21	949638-02	Rubber Plug	2				
*24	388657-00	Gear Case	1				
*26	330003-09	Ball Bearing	1				
27	388668-00	Spindle & Gear	1				
*28	176650-00	Gear Case Cover	1				
*29	23813-00	Fiber Washer	1				
43	136086-02	Terminal	4				
*45	330019-14	Screw	1				
46	176655-00	Gasket	1				
*50	93128-00	Needle Bearing	2				

**\*NOTES:**

- 8, 15 Cord clamp should be positioned, so that 30mm of cord jacket extends above the clamp.
- 9 Seal to face commutator. Press to the tubing on armature shaft.
- 10 To remove from shaft, place bearing in vise and crush outer race. Remove all internal bearing components, so that the inner race is all that is left. Use SRT320, Small Bearing Separator, to clamp the inner race and press off. Bearing presses to shoulder.
- 17,45,58 Torque to 18-23 inch-lbs.
- 18 Torque to 13 inch-lbs.
- 19 Small diameter end to face commutator. Lightly lubricate before installing into field case.
- 26 Press Bearing until seated completely in pocket. Rubber seal to face spindle and gear assembly.
- 28 Includes 10 and 50.
- 29 Press to bearing (item 10).
- 54 Press flush with surface facing spindle and gear assembly.



# INSTRUCTIONS FOR THE CARE OF THE KETT 40-20 SHEAR HEAD

**CAUTION**  
**Disconnect Power Unit**  
**Before Servicing Tool**



## PARTS LIST

40-21	Center Blade
40-23	Shear Housing
40-24	Eccentric Bearing Assembly
40-27	Spacer Bushing
92-28	Cap Screw (3)
92-31	Knurled Insert (3)
60-22L	Side Knife, Left
60-22R	Side Knife, Right
60-25	Thin Washer, Large
60-27	Spacer Bushing
60-29	(150-4) Allen Wrench

**DISASSEMBLY:** To remove the shear head from the motor loosen three cap screws (92-28). Remove shear head from motor by pulling head firmly forward. Slight tapping with a mallet may be required if head does not slide off easily.

To remove cutter blades from shear head remove three cap screws (92-28) from shear housing (40-23). Be careful not to lose rear spacer bushing (60-27) when removing the middle cap screw. Remove center blade (40-21) from shear housing by tapping blade gently rearward. Be careful not to lose spacer bushing (40-27) from hole in center blade. Side knives (60-22L and 60-22R) will now drop out of the shear housing.

To remove eccentric bearing assembly (40-24) from shaft use an appropriate wrench to loosen eccentric nut by turning counter clockwise.

**ASSEMBLY:** To install eccentric bearing assembly (40-24) onto shaft, make sure the large thin washer (60-25) is first inserted over the shaft. Screw eccentric bearing assembly on to shaft and tighten with appropriate wrench. Lubricate bearing with a good grade of bearing grease.

To install cutter blades into shear housing (40-23) place the side knives (60-22L and 60-22R) into position

in the shear housing (40-23). Insert center cap screw (92-28) through the side knives (60-22L and 60-22R) with rear spacer bushing (60-27) between them and start cap screw into thread just enough to hold blades in place. **DO NOT TIGHTEN.** Insert spacer bushing (40-27) into hole in center blade (40-21) and lubricate with Molybdenum Disulfide grease (264-2) or equivalent. Install center blade into shear housing by tapping blade gently forward using a drift to line up hole in center blade with forward holes in housing. Insert and tighten forward cap screw (92-28) making sure spacer bushing (40-27) in center blade stays in position. Apply Molybdenum Disulfide grease (264-2) or equivalent to clevis or yoke in center blade where it rides on the eccentric bearing assembly. Insert rear cap screw (92-28) into shear housing, but do not completely tighten.

To install shear head assembly onto drive motor make sure all cap screws (92-28) are loosened about three or four complete turns. Spread shear housing (40-23) slightly using a spreader (drift) near the rear cap screw (92-28). Place shear head onto unit, tap left side knife rearward as far as it will go, and tighten cap screws to 40-45 inch pounds. It may be necessary to gently tap the shear head into place if it does not readily slip onto the nose of the power unit.

**WARNING: THE KETT TOOL CO. CANNOT ASSUME RESPONSIBILITY FOR DAMAGE TO OR MALFUNCTION OF A KETT SHEAR HEAD USED IN COMBINATION WITH ANY DRILL OTHER THAN THOSE REGULARLY SUPPLIED BY US.**

## **GENERAL SAFETY RULES**

### **Warning**

When using electric tools basic safety precautions should always be followed to reduce the risk of fire, electric shock, and personal injury, including the following:

*Read all instructions.*

*Save these instructions.*

### **For KD-440 and all double insulated tools:**

When servicing, use only identical replacement parts.

### **Guard Against Electric Shock**

Prevent body contact with grounded surfaces, for example: pipes, radiators, ranges, refrigerator enclosures.

### **Keep Children Away**

Do not let visitors contact tool or extension cord. All visitors should be kept away from work area.

### **Store Idle Tools**

When not in use, tools should be stored in dry, high or locked-up place out of reach of children.

### **Don't Force Tool**

It will do the job better and safer at the rate for which it was designed.

### **Use Right Tool**

Don't force a small tool to do the job of a heavy duty tool. Don't use tool for on purpose not intended, for example-don't use a circular saw for cutting tree limbs or logs.

### **Dress Properly**

Do not wear loose clothing or jewelry. They can be caught in moving parts. Rubber gloves and footwear are recommended when working out doors.

Wear protective hair covering to contain long hair.

### **Use Safety Glasses**

Use safety equipment. Always wear eye protection.

### **Don't Abuse Cord**

Never carry tool by cord or yank it to disconnect from receptacle. Keep cord from heat, oil, and sharp edges. Replace damaged cords immediately.

### **Secure Work**

Use clamps or vise to hold work. It's safer than using your hand and it frees both hands to operate tool.

### **Don't Overreach.**

Keep proper footing and balance at all times.

### **Maintain Tools with Care**

Keep tools sharp and clean for best and safest performance. Follow instructions for lubricating and changing center blades and side knives. Inspect tool cords periodically and if damaged, have repaired by authorized service facility. Inspect extension cords periodically and if damaged or replace. Keep handles dry, clean, and be free from oil and grease.

### **Disconnect Tools**

When not in use; before servicing; when changing Center Blades, Side Knives, Brushes, etc.

### **Remove Adjusting keys and Wrenches**

Form Habit of checking to see that keys and adjusting wrenches are removed from tool before turning it on.

### **Keep Work Area Clean**

Cluttered areas and benches invite accidents. Keep work area well lit.

**Avoid Dangerous Environment** Don't expose power tools to rain or snow. Don't use power tools in damp or wet locations.

## **SYMBOLS**

The symbol on the Caution Label is mean to convey this message. Ne pas exposer a la pluie et ne pas utiliser dans les emplacements humides. Don't use power tools in damp or wet locations.



### **Definitions of Symbols**

$N_0$  = No load speed

/min = per minute

Double insulated motor =



CSA Canadian Standard Association =



Underwriters Laboratory =



### **Motor**

Be sure your power supply agrees with nameplate marking. Use Alternating Current Only (50 to 60 Cycles), 120 volts. Voltage variation of more than 10% will cause loss of power and overheating. Motors are factory tested. If this shear does not operate, check the following: supply line for blown fuses; plug and receptacle for contact. This tool will stop when the brushes wear to a preset length. Damage to the motor is thus avoided.

## **FUNCTIONAL DESCRIPTION**

Please read carefully all safety rules and operating instructions. The Model KD-440 Shear is recommended for CR sheet steel up to 14 gage. Secure work piece. To start cut, place side knives of shear slightly on the edge of the top side of the work piece to steady the tool and ready it for the cut. Depress the trigger switch and guide shear into the work. Do not force it. Avoid double thicknesses of material which exceed the 14 gage recommended capacity. For cutting within perimeter of work piece, drill a 1/2" diameter starting hole and follow instructions above. If resistance to tool develops or cutting becomes difficult, discontinue cutting and check the following: lubrication; thickness of material; sharpness of cutting blades.

## **OPERATION**

### **Avoid Accidental Starting**

Don't carry plugged-in tool with finger on switch. Be sure switch is OFF when plugging in. Use of any accessory with this power unit might increase the hazard. The tool should be used only for the purpose for which it is designed.

### **Plug**

THE POLARIZED PLUG IS A SAFETY FEATURE. This tool is equipped with a polarized two wire AC line plug. The two wire polarized plug (having one blade wider than the other) will fit into the power outlet only one way. DO NOT DEFEAT THE SAFETY PURPOSE OF THE POLARIZED PLUG, by tampering with it. If the plug does not fit you should still be unable to fully insert the plug into the socket, you may find that a proper outlet is needed to meet today's electrical standards. An electrician will replace your outlet safely.

### **Extension Cords**

Always check the extension cord and repair or replace if damaged.

### **Outdoor Use Extension Cords**

When tool is used outdoors, use only extension cords marked W-A or W.

### **Stay Alert**

Watch what you are doing, use common sense when operating a power tool. Do not use tool while tired or under the influence of drugs, alcohol or medication.

### **Check Damaged Parts**

Before further use of the tool, a guard or other part that is damaged should be carefully checked to determine that it will operate properly and perform its intended function. Check for alignment if moving parts, binding or moving parts, breakage of parts, mounting, and any other conditions that may affect its operation. A guard or other part that is damaged should be properly repaired or replaced by an authorized service center unless otherwise indicated elsewhere in this instruction manual. Have defective switches replaced by authorized service center. Do not use tool if switch does not turn it on or off.

**DO NOT OPERATE** power tools in explosive atmospheres such as in the presence of flammable liquids, gases, or dust. Motors in these tools normally spark and sparks can possibly ignite fumes.

*Read all instruction.*

*Save these instructions.*

## **MAINTENANCE**

When servicing, use only identical replacement parts. Tool may be cleaned and lubricated by the user, but any other servicing, including the changing of carbon brushes, should be performed by the manufacturer or any authorized representative or service station.

### **Cable**

The cable or cord is the "life line" of your tool. Keep it clean by wiping it off occasionally. Keep it out of oils and greases. Coil it neatly when not in use and avoid dragging it across sharp surfaces or using it as a handle to lift the tool.

When using the tool at a considerable distance from power source, an extension cable of adequate size must be used to prevent loss of power and overheating.

For extension cables up to 75 feet use number 18; for 100 feet use number 16; and for up to 200 feet use number 14 wire gage. If you are working with a 230 volt tool, cable lengths may be doubled using the same wire gage sizes as prescribed above for the 120 volt tool.

### **Lubrication**

#### **Always disconnect KD-440 Electric Shear from power source before lubricating.**

Once every three months, depending upon usage, remove the shear Head from the power unit following the instructions given on the service sheet under the heading "Disassembly-To remove the shear head assembly (40-20) from the drive motor." Put a few drops of heavy oil on the Eccentric Bearing Assembly (40-24), so that it saturates the needle bearing (40-24- 2). Grease is even better if it can be forced or pressed into the needle bearing rollers. The outside surface of the Eccentric Bearing Ring (40-24-3) should also be greased.

Tools that have seen continuous use should also have the gear train lubricated periodically, preferably at the same time the eccentric bearing assembly is serviced. To lubricate the gears remove the screws that hold the gear case to the motor shell. Remove the gear case from the cover plate and wipe out the old grease with a cloth. Wash the gears and spindles with kerosene or cleaning fluid. Refill the gear case ONLY 1/3 FULL with a good standard gear grease. Never fill more than 1/3. The Ball bearing in the gear case is a closed type bearing. It has been permanently lubricated at the factory to last the life of the bearing. This bearing should NEVER be immersed in a solvent or cleaning fluid.

Adherence to these maintenance instructions will greatly increase the life of your Model KD-440 Electric Shear, so it will give you long and satisfactory service.



The Kett Tool Company . 5055 Madison Road . Cincinnati, Ohio 45247

513/271-0333 FAX 513/271-5318  
www.kett-tool.com  
info@kett-tool.com

K07-254