

## PROCEDURES

### TOOLS REQUIRED

Phillips screwdriver,  $\frac{3}{8}$ " wrench

1. Advance provides 6" on center mounting holes for the E3 cordset on all of its tables.
2. To install the cordset, insert the molded receptacle through the rectangular slot in the cordwind bracket.
3. Fasten the cordset/bracket to the table with the #10 fasteners provided. Refer to the illustration for detail.
4. Wind the cord around the cordwind bracket when the table is in transport or cordset is not in use.

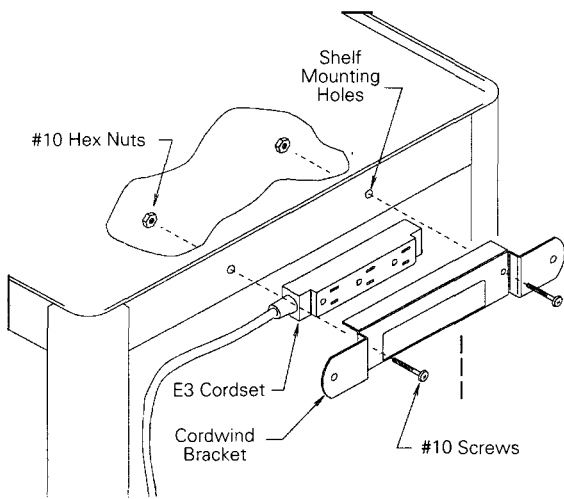



**DA-LITE**®

***Assembly Instructions***  
***For***  
***ADVANCE***  
***E-3 CORDSET***

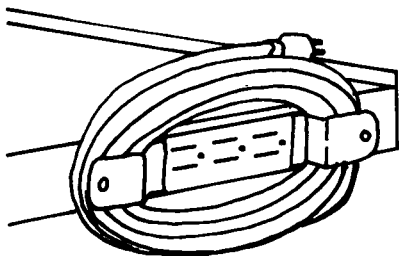

**DA-LITE SCREEN  
COMPANY, INC.**

3100 North Detroit Street  
Post Office Box 137  
Warsaw, IN 46581-0137  
Phone: 219/267-8101  
1-800-622-3737  
Fax: 219/267-7804  
[http:// www.da-lite.com](http://www.da-lite.com)  
e-mail: [info@da-lite.com](mailto:info@da-lite.com)

## PROCEDURES

### TOOLS REQUIRED

Phillips screwdriver

1. Unpack cordset and cord wind bracket.  
Arrange and organize related hardware as shown.
2. Fasten cord wind bracket to cordset with the phillips screws.
3. Fasten cordset/bracket assembly to table through mounting bolts

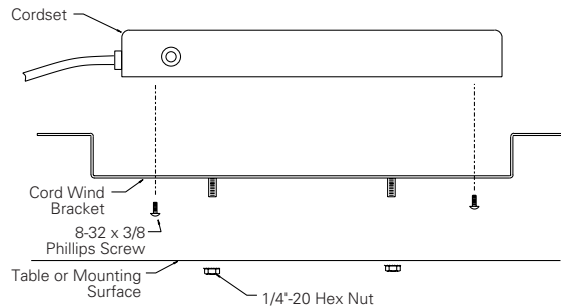

### Cordset Specifications

Electrical Rating	125 VAC
Max. Surge Voltage	6,000 volts
Max. Surge Dissipation	50 Joules
Max. Spike Current	45,000 amps @ 25° C.
Max. Clamping Ratio	1.2:1
Clamping Voltage	175 Volts
Clamping Response Time	< 10 nanoseconds
Temperature Range	-40 C to + 80 C

The  
**POWER** *In*  
**PRESENTATION PRODUCTS**



**DA-LITE**

### Assembly Instructions for **ADVANCE E6S2 CORDSET**

#### **DA-LITE SCREEN COMPANY, INC.**

3100 North Detroit Street  
Post Office Box 137  
Warsaw, Indiana 46581-0137  
Phone: 574-267-8101  
800-622-3737  
Fax: 574-267-7804  
www.da-lite.com  
e-mail: info@da-lite.com