

# The Da-Lite Difference.

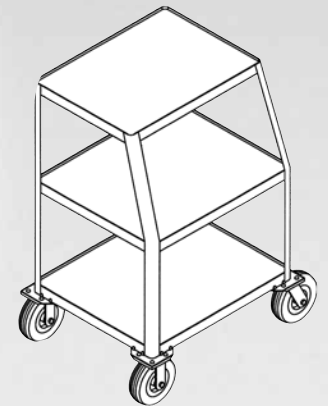

**Assembly Instructions for  
ADVANCE  
A-575 LOADTOTER**



**DA-LITE SCREEN COMPANY, INC.**  
3100 North Detroit Street  
Post Office Box 137  
Warsaw, Indiana 46581-0137  
Phone: 574-267-8101  
800-622-3737  
Fax: 574-267-7804  
Toll Free Fax: 877-325-4832  
[www.da-lite.com](http://www.da-lite.com)  
e-mail: [info@da-lite.com](mailto:info@da-lite.com)

The A-575 Loadtoter assembly is designed to install on any Advance table with a full bottom shelf. No cutting or drilling is required.

## PROCEDURES

### TOOLS REQUIRED

½" box wrench

### ITEMS INCLUDE:

- 2 Rigid Casters
- 2 Swivel Casters
- 4 Caster Brackets
- 4 Bolt Plates
- 25 ⅝ -18 x ¾ Carriage Bolts
- 29 ⅝ -18 Hex Nuts
- 4 ⅝ -18 x 1 Flat Head Screws

### MOUNTING PROCEDURES

1. Invert the table to ease assembly. (Figure 1)
2. Place a bolt plate in a corner of the table, making sure it locates beneath the shelf flanges. Hold a ⅝ -18 hex nut beneath the round hole in the bolt plate. (Figure 2)
3. Insert one ⅝ -18 x ¾ carriage bolt through the square hole in the caster bracket. Place the caster bracket over the bolt plate and table corner, making sure the four tabs are to the outside of the table. Insert the ⅝ -18 x 1 flat head screw through the caster bracket and bolt plate and tighten just enough to hold the entire assembly in position. (Figure 3)

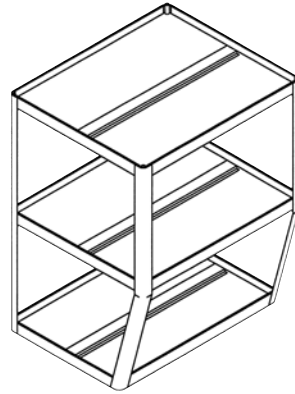

Figure 1

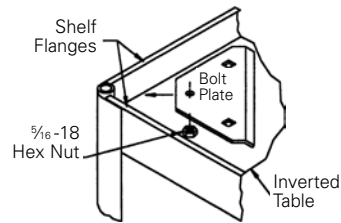

Figure 2

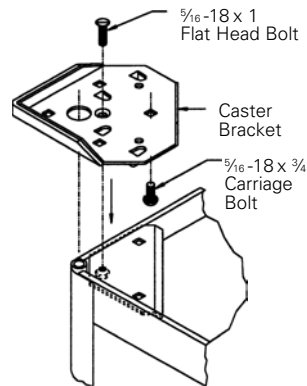

Figure 3

4. Insert two ⅝ -18 x ¾ carriage bolts through the bolt plate and caster bracket from beneath the bolt plate. Using two ⅝ -18 hex nuts, tighten these bolts along with the ⅝ -18 x 1 flat head screw installed previously. Tighten all three bolts securely, flattening the shelf flange. (Figure 4)

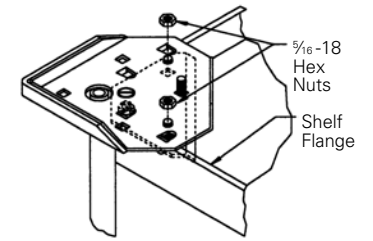

Figure 4

5. Mount the casters to the caster brackets using three ⅝ -18 x ¾ carriage bolts and the carriage bolt installed prior to fastening the caster bracket to the bolt plate. The casters are provided with slotted mounting holes to allow proper alignment with the shelf edge.

**IMPORTANT:** The two rigid casters must be mounted so that they run parallel to the longer side of the table.

6. Tighten hex nuts (Figures 5 and 6).

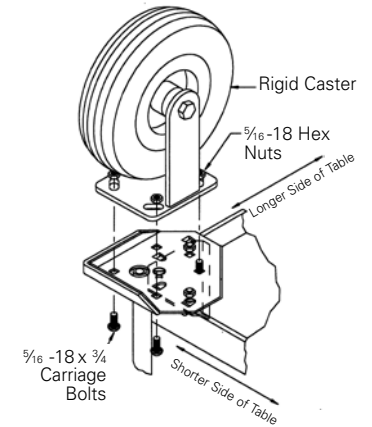

Figure 5

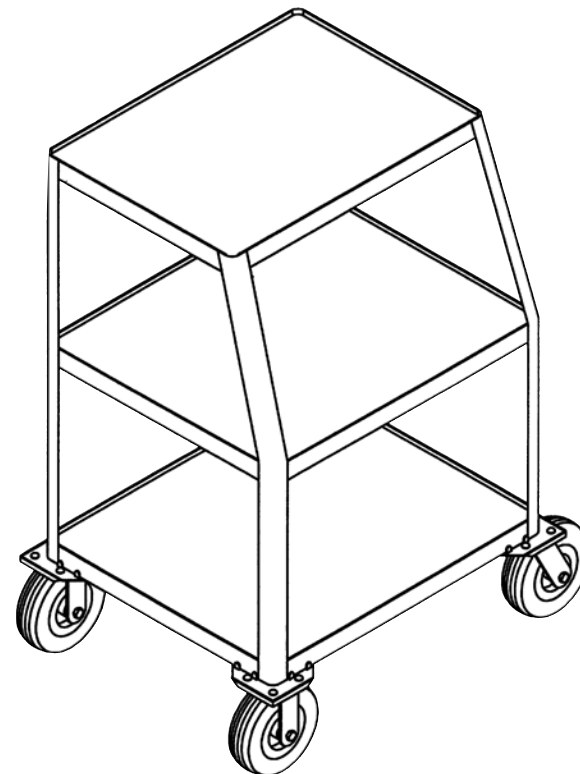

Figure 6