

# The Da-Lite Difference.



## Instruction Book for **TENSIONED PROFESSIONAL ELECTROL®**



### **DA-LITE SCREEN COMPANY, INC.**

3100 North Detroit Street  
Post Office Box 137  
Warsaw, Indiana 46581-0137  
Phone: 574-267-8101  
800-622-3737  
Fax: 574-267-7804  
[www.da-lite.com](http://www.da-lite.com)  
e-mail: [info@da-lite.com](mailto:info@da-lite.com)

# ***IMPORTANT SAFETY INSTRUCTIONS***

When using your video equipment, basic safety precautions should always be followed, including the following:

1. Read and understand all instructions before using.
2. Position the cord so that it will not be tripped over, pulled, or contact hot surfaces.
3. If an extension cord is necessary, a cord with a current rating at least equal to that of the appliance should be used. Cords rated for less amperage than the appliance may overheat.
4. To reduce the risk of electric shock, do not disassemble this appliance. Contact an authorized service dealer when repair work is required. Incorrect reassembly can cause electric shock when the appliance is used subsequently.
5. The use of an accessory attachment not recommended by the manufacturer may cause a risk of fire, electric shock, or injury to persons.

**SAVE THESE INSTRUCTIONS**

## PRE-INSTALLATION

1. Carefully unpack screen.
2. Make sure to recheck measurements of screen location before installation.
3. Remove instruction cover plate (Fig. 1). Do not remove wrapping paper until screen is installed.
4. Remove the retainer screws from the slat bar before the case has been installed (Fig. 2).

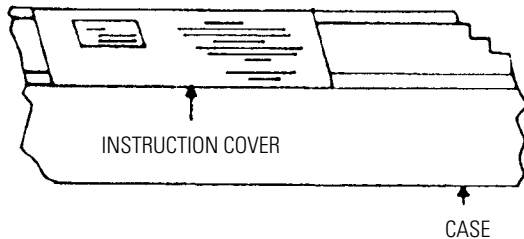

FIGURE 1

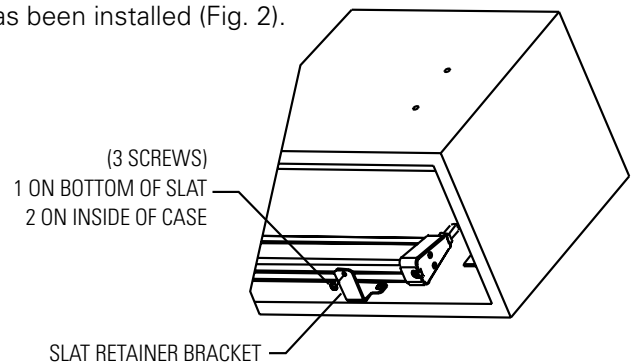

FIGURE 2

## INSTALLATION

Hangers (If required)

1. Make sure a hanger is approximately 11-1/2" from each end of case.
2. Place third hanger on the center line of the fabric.

Installation

1. Level unit lengthwise with a carpenter's plum level.

**CAUTION! DO NOT COMPLETELY SEAL IN UNIT. ACCESS ROOM MUST BE ALLOWED FOR MOTOR REPAIR OR FABRIC REPLACEMENT.**

2. Remove shipping brace by removing 2 hex head screws (Figure 3).
3. Remove wrapping paper.

**CAUTION! DO NOT CUT WRAPPING PAPER WITH KNIFE OR ANY SHARP TOOL. REMOVE BY HAND.**

4. Install electrical hook up that applies to your unit. Make sure to review your Electrical Installation Checklists and wiring diagrams (included) for either 110 volt switch, 220/240 volt switch, or DRC low voltage control.
5. Test installation by carefully running surface up and down several times. Be prepared to stop screen.

**NOTE: The picture surface, when rolled down, should have at least a full wrap and a half around the roller. Do not allow any part of the roller to become exposed.**

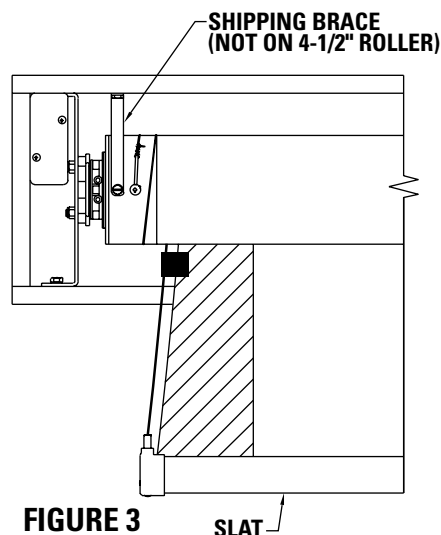
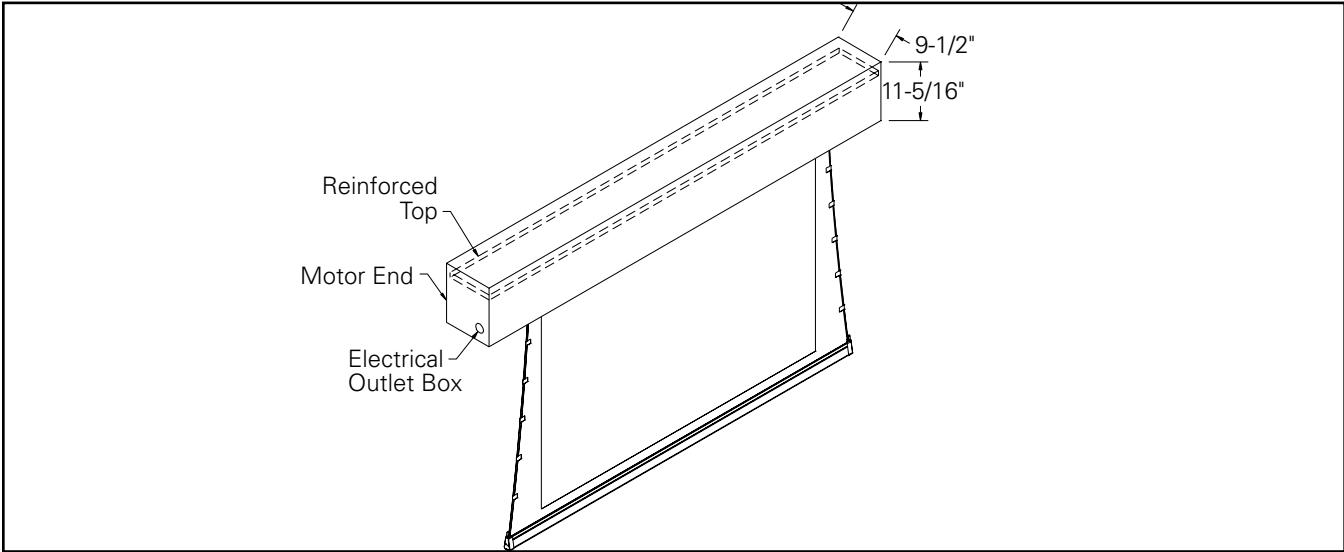
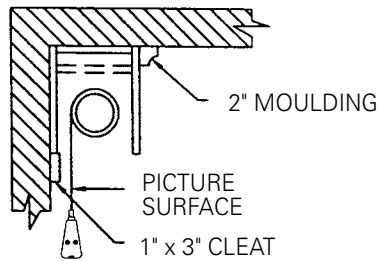
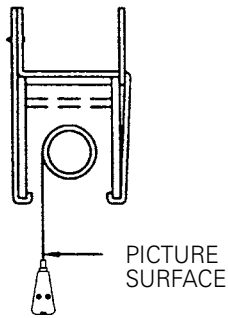

FIGURE 3



**SUGGESTED METHODS OF INSTALLATION**

**CEILING TYPE HANGER**



**CEILING MOUNT WITHOUT HANGERS**

Screen case is placed flush with the wall and ceiling and held in position by moulding securely attached to the wall.

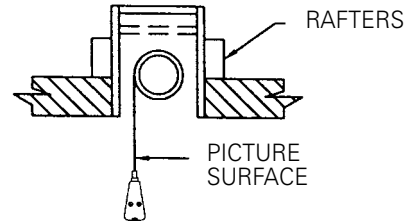

**RECESSED ABOVE CEILING**

Other methods of installation will suggest themselves in new buildings where it would be an easy matter to provide a recess for the screen to conceal it when not in use.

Do not seal in—allow access.

**WALL TYPE HANGER**

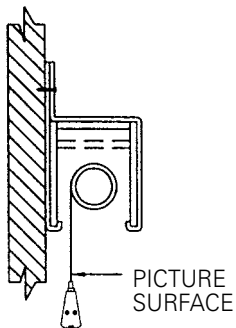

**WALL OR CEILING MOUNT WITH HANGERS**

Wall type hangers and ceiling type hangers are standard equipment. One set is supplied with each screen. Useful for recessed installations.

**FOR EXPOSED INSTALLATION**

If the screen is to be mounted in an exposed position, it may be covered with finished plywood, veneer, paneling, plastic wall covering or a valance.

## TENSIONED PROFESSIONAL ELECTROL® INSTALLATION

### 120V WIRING DIAGRAM

IN MULTIPLE CONTROL INSTALLATIONS THE SWITCH IS REPLACED BY THE LOW VOLTAGE CONTROL, OPERATED FROM PUSH BUTTON STATIONS.

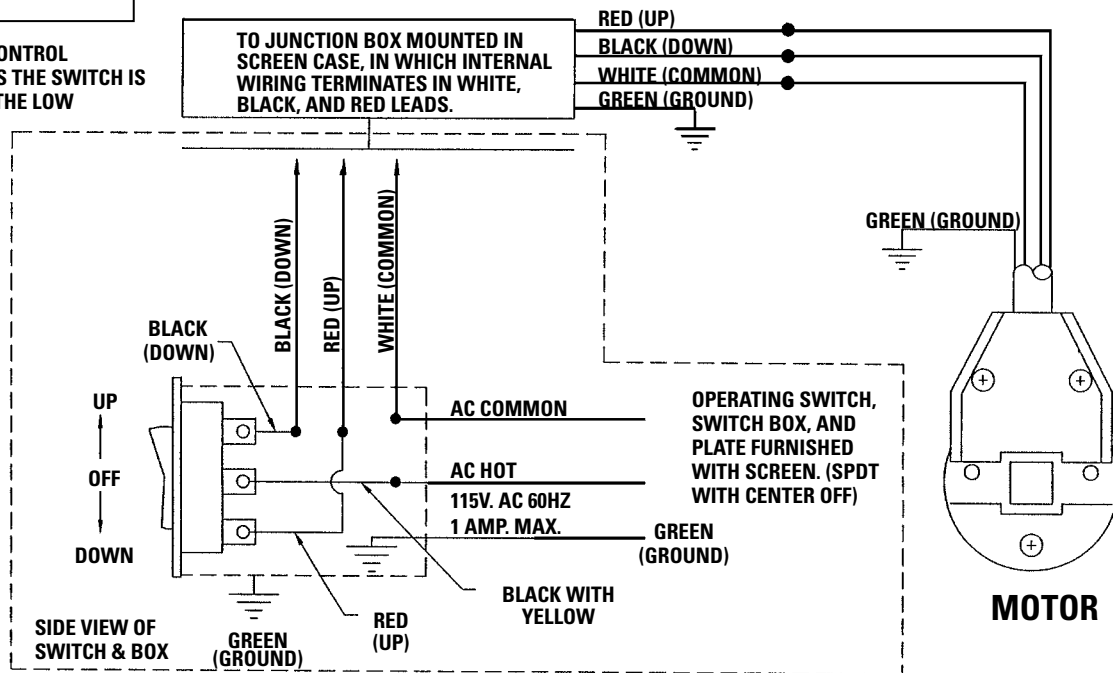

THIS SWITCH CANNOT BE USED WITH L.V.C.

NOTE: A SINGLE SWITCH CANNOT BE USED TO OPERATE MORE THAN ONE SCREEN. CONTACT THE FACTORY FOR FURTHER INFORMATION.

### 240 VOLT WIRING DIAGRAM FOR STANDARD WALL SWITCH:

Da-Lite offers two styles of 240 volt wall switches for standard operation. Please see wiring diagram in wall switch box included with screen.

## SCREEN ADJUSTMENT

Surface travel is stopped automatically in the fully opened and closed positions by limit switches that are properly adjusted at Da-Lite.



CONTACT DA-LITE AT 800-622-3737 OR 574-267-8101 IF SCREEN MOTOR NEEDS ADJUSTMENT.

## TROUBLESHOOTING

Visit [www.da-lite.com/products/tutorials.php](http://www.da-lite.com/products/tutorials.php) to find installation and troubleshooting tutorials. You will also find a link to Live Chat for interactive support and you can contact us by email at [info@da-lite.com](mailto:info@da-lite.com) or by phone at (800) 622-3737 or (574) 267-8101 with any troubleshooting questions.

SYMPTOM	CAUSE	SOLUTION
1. Screen will not operate. Motor does <b>not</b> hum.	<p>(a) Blown fuse. (b) Tripped circuit breaker. (c) No power to operating switch or junction.</p> <p>Power at junction box</p> <p>(d) Thermal overload tripped. (e) Broken wire in the <b>"down"</b> or <b>"up"</b> position. (f) Defective motor, limit switch or capacitor. (g) Capacitor burned out.</p>	<p>(a) Replace fuse. (b) Reset circuit breaker. (c) Check above. Tighten all loose wire connections. Correct any improper connections. <b>"Down" Position</b> Check for power across black and white leads. <b>"Up" Position</b> Check for power across red and white leads.</p> <p>(d) Let motor cool down for 15 minutes. Try again. (e) Check for continuity. Cut off old splice and reconnect. (f) Replace motor assembly. <b>NOTE: Motor is a sealed assembly.</b> (g) Replace motor assembly.</p>
2. Incorrect stopping position in <b>downward</b> direction.	<p>(a) Lost roller wrap. (b) <b>"Down"</b> limit switch out of adjustment</p>	<p>(a) See instructions below. (b) Contact Da-Lite at 800-622-3737 or 574-267-8101</p>
3. Incorrect stopping position in <b>upward</b> direction.	<p>(a) Lost roller wrap. (b) <b>"Up"</b> limit switch out of adjustment</p>	<p>(a) See instructions below. (b) Contact Da-Lite at 800-622-3737 or 574-267-8101</p>
4. Noise. <b>NOTE: Screen will operate with a low pitched hum.</b>	<p>(a) Gear Noise.</p>	<p>(a) Replace motor assembly.</p>
5. Coasting.	<p>(a) Defective brake.</p>	<p>(a) Replace motor assembly.</p>

**THIS PAGE IS INTENTIONALLY LEFT BLANK**

**LIMITED ONE YEAR WARRANTY  
ON DA-LITE PRESENTATION PRODUCTS**

Da-Lite Screen Company, Inc. warrants its products to the original purchaser only, to be free from defects in materials and workmanship for a period of one (1) year from the date of purchase by the original purchaser provided they are properly operated according to Da-Lite's instructions and are not damaged due to improper handling or treatment after shipment from the factory.

This warranty does not apply to equipment showing evidence of misuse, abuse or accidental damage, or which has been tampered with or repaired by a person other than authorized Da-Lite personnel.

Da-Lite's sole obligation under this warranty shall be to repair or to replace (at Da-Lite's option) the defective part of the merchandise. Returns for service should be made to your Da-Lite dealer. If it is necessary for the dealer to return the screen or part to Da-Lite, transportation expenses to and from Da-Lite are payable by the purchaser and Da-Lite is not responsible for damage in shipment. To protect yourself against damage or loss in transit, insure the product and prepay all transportation expenses.

**THIS WARRANTY IS IN LIEU OF ALL OTHER WARRANTIES, EXPRESS OR IMPLIED, INCLUDING WARRANTIES AS TO FITNESS FOR USE AND MERCHANT ABILITY.** Any implied warranties of fitness for use, or merchantability, that may be mandated by statute or rule of law are limited to the one (1) year warranty period. This warranty gives you specific legal rights, and you may also have other rights, which vary from state-to-state. **NO LIABILITY IS ASSUMED FOR EXPENSES OR DAMAGES RESULTING FROM INTERRUPTION IN OPERATION OF EQUIPMENT, OR FOR INCIDENTAL, DIRECT, OR CONSEQUENTIAL DAMAGES OF ANY NATURE.**

In the event that there is a defect in materials or workmanship of a Da-Lite product, you may contact our Sales Partners at PO Box 137, Warsaw, IN 46581-0137, (574) 267-8101, (800) 622-3737.

**IMPORTANT: THIS WARRANTY SHALL NOT BE VALID AND DA-LITE SHALL NOT BE BOUND BY THIS WARRANTY IF THE PRODUCT IS NOT OPERATED IN ACCORDANCE WITH DA-LITE'S WRITTEN INSTRUCTIONS.**

Keep your sales receipt to prove the date of purchase and your original ownership.