

**PIXMobile® PRE-ASSEMBLED MONITOR/TELEVISION CARTS**

- 20" x 30" top shelf and extra wide base for added stability when moving heavier monitors and televisions.
- Fully assembled for convenience and robotically arc welded for superior strength.
- High quality 4" casters standard.
- AV5CM-54J includes an extra shelf.
- Center shelf adjusts with top shelf.
- Optional UL listed six outlet surge suppressor or three outlet electrical assembly with cord wind bracket available.



AV5C-54J

**PIXMOBILE® FULLY ARC-WELDED WITH METAL CABINET AND 20" X 30" SHELF**

Model	Dimensions H x W x D	
	in.	cm.
AV5C-54J	54" x 30" x 20"	137 x 76 x 51
AV5CM-54J	54" x 30" x 20"	137 x 76 x 51

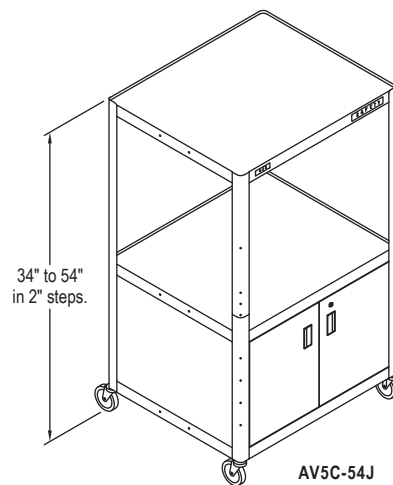

AV5C-54J