

**PIXMobile® PRE-ASSEMBLED PROJECTION CARTS**



AVCT2C-42J



AV2-42J



AV2C-42J

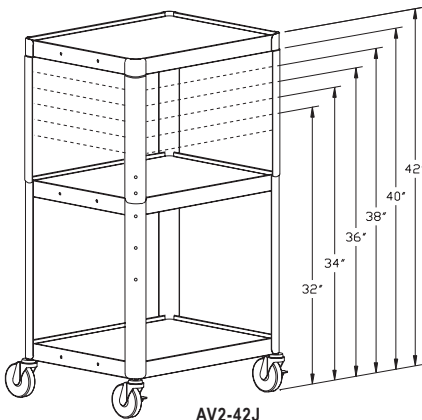

AV2-42J

- AV1 model offers a 14" x 18" top shelf. AV2 model carts provide an 18" x 24" top shelf.
- Fully assembled for convenience and robotically arc welded for added strength.
- Fixed center shelf with 32" high and above models.
- Optional UL listed six outlet surge suppressor or three outlet electrical assembly with cord wind bracket available.
- Cabinet model offers storage cabinet measuring 18" D x 24" W with 17 1/4" H opening.
- High quality 4" casters and o-rings for smooth and easy operation.
- Models with "J" designation indicates adjustable height in 2" increments.

**PIXMOBILE® FULLY ARC-WELDED WITH 14" X 18" SHELF**

Model	Dimensions H x W x D	
	in.	cm.
AV1-32	32" x 18" x 14"	81 x 46 x 36

**PIXMOBILE® FULLY ARC-WELDED WITH 18" X 24" SHELF**

Model	Dimensions H x W x D	
	in.	cm.
AV2-26	26" x 24" x 18"	66 x 61 x 46
AV2-34	34" x 24" x 18"	86 x 61 x 46
AV2-42	42" x 24" x 18"	107 x 61 x 46
AV2-42J	42" x 24" x 18"	107 x 61 x 46
AVCT2-42J	42" x 24" x 18"	107 x 61 x 46
AV2-KS	Keyboard Shelf	

**PIXMOBILE® METAL CABINET AND 18" X 24" SHELF**

Model	Dimensions H x W x D	
	in.	cm.
AV2C-42J	42" x 24" x 18"	107 x 61 x 46
AVCT2C-42J	42" x 24" x 18"	107 x 61 x 46
AT2C-42JFS	42" x 24" x 18"	107 x 61 x 46
AV2-KS	Keyboard Shelf	