

Lieber Kunde,

Sie haben sich für ein Qualitätsprodukt entschieden. Wir sind immer bemüht, Sie mit einer einwandfreien Lieferung zufrieden zu stellen. Sollte trotzdem ein Beschlagteil fehlen oder mangelhaft sein, wollen wir Sie schnellstens durch Postversand mit den notwendigen Ersatzteilen bedienen.

Kreuzen Sie bitte in Ihrer Montageanweisung die Teile unmissverständlich an, die ersetzt oder nachgeliefert werden müssen und informieren Sie uns nachstehend über Ihre Postanschrift.

Name:
Straße:
Land / PLZ / Ort: (für eventuelle Rückfragen)
Telefon-Nr.:
Artikel + Farbe:

Reinigungs- und Pflegehinweise























Verwenden Sie zum Reinigen bitte einfach ein weiches, feuchtes Tuch. Bitte benutzen Sie niemals scheuernde und / oder lösungsmittelhaltige Putzmittel, da diese die Oberflächen zerkratzen oder beschädigen können. Mit saugfähigen, sauberen Wisch- oder Papiertüchern ist die Oberfläche nachzutrocknen. Bei Hochglanzoberflächen bitte ausschließlich weiche Baumwolltücher verwenden.

Reinigungsmittel welche auf keinen Fall verwendet werden dürfen:

- Schleifende und scheuernde Mittel, wie Scheuerpulver, Putzschwämme mit rauer Seite oder Stahlwolle
- Poliermittel, Waschmittel, Möbelputzmittel oder Bleichmittel
- Reinigungsmittel mit starken Säuren und stark sauren Salzen
- Dampfreinigungsgeräte

Montagehinweise

- Der Aufbau des Möbels muss zwingend nach der Aufbauanleitung erfolgen. Bei Nichtbeachtung kann eine fehlerhafte Montage zu Beschädigungen, Funktionsbeeinträchtigungen und Verletzungsgefahr führen.
- Einzelteile nur auf weicher Unterlage montieren!
- Das beigelegte Befestigungsmaterial ist nur für festes Mauerwerk geeignet! Bitte immer Befestigungsmaterial verwenden, das für die betroffenen Wände geeignet ist. Bei Bedarf informieren Sie sich am besten vorab im Fachhandel.

- | | | |
|---------------------------------------------------------------------------------------------------------------------------------------------------------------------------------------|-----------------------------------------------------------------------------------------------------------------------------------------------------------------------------------------------------------------------------------------|--------------------------------------------------------------------------------------------------------------------------------------------------------------------------------------------------------------------------------|
|   1 = links |   5 = Optionales Zubehör |   9 = Wichtig: Kippsicherung |
|   2 = rechts |   6 = Ankörnschablone |   10 = Wichtig: Aussprungsicherung beachten! |
|   3 = oben |   7 = Demontage der Tür |   11 = Wenn vorhanden, mit Eckschrank beginnen! |
|   4 = vorne |   8 = Dieses Möbelstück muss an der Wand befestigt werden. | |

Dear Customer,

You have chosen a quality product. We always try our best to satisfy you with a perfect delivery. If a fitting should be missing or faulty, however, we want to send you the necessary replacement parts by post as soon as possible.

Please clearly tick the parts in your assembly instructions, which need to be replaced or delivered in addition and tell us your postal address underneath.

Name:
Street:
Country/Postcode/Town: (for any questions)
Telephone no.:
Product + colour:

Cleaning and care information























For cleaning purposes, simply use a soft, damp cloth. Please never use scouring and / or solvent-based cleaning products, as these may scratch or damage the surfaces. The surface should be dried off with absorbent, clean cloths or paper towels. Please only use cotton cloths on high gloss surfaces.

Cleaning agents which definitely must not be used:

- Grinding or abrasive products, such as scouring powder, sponge with rough side or steel wool
- Polishes, washing agents, furniture cleaners or bleaches
- Cleaning agents with strong acids and strong acid salts
- Steam cleaners

Assembly instructions

- The furniture must be assembled according to the assembly instructions. If the instructions are not followed, a faulty assembly can lead to damage, impaired functionality and risk of injury.
- Only assemble parts on soft underlayer!
- The attached fastening material is only suitable for solid brickwork! Please always use fastening material that is suitable for the walls in question. If necessary, it is best to seek advice first at a specialist shop.

- | | | |
|---------------------------------------------------------------------------------------------------------------------------------------------------------------------------------------|------------------------------------------------------------------------------------------------------------------------------------------------------------------------------------------------------------------------------------------|------------------------------------------------------------------------------------------------------------------------------------------------------------------------------------------------------------------------------------|
|   1 = left |   5 = Optional accessories |   9 = Important: Anti-tilt device |
|   2 = right |   6 = Hole-marking template |   10 = Important: Take care of pop-out safeguard! |
|   3 = top |   7 = Dismantling the door |   11 = If present, start with corner unit! |
|   4 = front |   8 = This piece of furniture must be fastened to the wall. | |

Cher client,

Vous avez opté pour un produit de qualité. Nous nous efforçons de vous satisfaire par une livraison irréprochable. Si une pièce de ferrure manque ou est défectueuse, nous vous expédions le plus vite possible les pièces de rechange nécessaires par envoi postal.

Sur votre instruction de montage, cocher catégoriquement les pièces devant être remplacées ou livrées ultérieurement et nous informer ci-après de votre adresse postale.

Nom:

Rue:

Pays / CP / Ville:

Téléphone n°:

(pour demandes éventuelles)

Article + couleur:

Consignes de nettoyage et d'entretien



Pour nettoyer, utiliser simplement un chiffon doux humide, jamais de nettoyeurs abrasifs et/ou à base de solvant, car ils peuvent rayer ou endommager les surfaces. Sécher la surface avec un chiffon à essuyer ou en papier absorbant et propre. Pour les surfaces de grande brillance, utiliser uniquement des chiffons en coton doux.

Nettoyants à n'utiliser en aucun cas:



- Produits abrasifs comme poudre à récurer, éponge à côté rugueux ou paille de fer
- Produit à polir, lessive, nettoyeur de meubles ou décolorant
- Nettoyeurs fortement acides et sels fortement acides
- Nettoyeurs à pression



Instructions de montage

- Effectuer le montage du meuble impérativement suivant l'instruction de montage. Sinon, il existe un risque de dommages, d'influences négatives sur la fonction et de blessure.
- Monter les éléments uniquement sur un fond souple!
- Le matériel de fixation joint convient uniquement à une maçonnerie solide! Toujours utiliser le matériel de fixation approprié aux murs concernés. Si besoin est, s'informer d'abord auprès du commerçant spécialisé.



  **1** = à gauche

  **5** = Accessoire optionnel

  **9** = Important: sécurité basculement

  **2** = à droite

  **6** = Gabarit de centrage



  **10** = Important: observer sécurité d'arrêt!

  **3** = haut

  **7** = Démontage de la porte

  **11** = Si possible, commencer par l'encoignure!

  **4** = devant

  **8** = Ce meuble doit être fixé au mur.

Estimado cliente,

Se ha decidido por un producto de calidad. Siempre nos esforzamos en satisfacerle con una entrega impecable. Si a pesar de todo llegase a faltar una pieza o que estuviera defectuosa, queremos servirle lo más rápidamente posible por correo con las piezas de recambio necesarias.

En sus indicaciones de montaje marque claramente con una cruz las piezas que deben ser cambiadas o enviadas y comuníquenos a continuación su dirección.

Nombre:

Calle:

País/código postal/lugar:

N° de teléfono:

(para preguntas eventuales)

Artículo+color:

Consejos de limpieza y de mantenimiento



Para la limpieza, basta utilizar un paño suave y húmedo. Nunca utilice productos de limpieza abrasivos y / o que contienen disolventes, ya que pueden rayar o dañar la superficie. Después seque la superficie con un papel o paño limpio y absorbente. Para superficies brillantes, use solamente un paño suave de algodón.

Productos de limpieza que no se pueden utilizar en ningún caso:

- Productos abrasivos o pulidores, como limpiadores en polvo, estropajos ásperos o lana de acero
- Pulidores, detergentes, limpiamuebles o blanqueadores
- productos de limpieza con ácidos fuertes y sales muy ácidas
- Limpiadores a vapor



Indicaciones de montaje

- El montaje del mueble debe hacerse imperativamente según las instrucciones de montaje. Si no se hace así, un falso montaje puede provocar daños, perjuicios en las funciones y riesgos de lesiones.
- Monte las piezas sólo encima de una base suave!
- El material de fijación adjunto sólo está adaptado para mamposterías fijas! Use siempre material de fijación que este adaptado para las paredes afectadas. Si necesario, pregunte primero en la tienda especializada.



  **1** = izquierda

  **5** = Accesorios en opción



  **9** = Importante: antibasculante



  **2** = derecha



  **6** = Plantilla de punzonar



  **10** = Ojo: Piense en el seguro anti-soltura!

  **3** = arriba

  **7** = Desmontaje de la puerta

  **11** = Empiece, si hay, con el armario rinconero!

  **4** = delante

  **8** = Este mueble debe ser montado en la pared.

Beste klant,

U heeft gekozen voor een kwaliteitsproduct. We trachten ernaar u steeds tevreden te stellen met een foutloze levering. Indien toch een passend onderdeel ontbreekt of defect is, willen wij u zo snel mogelijk via de post met de nodige vervangstukken bedienen.

Gelieve in uw montageinstructie de onderdelen aan te kruisen die moeten worden vervangen of nageleverd en vul hieronder uw postadres in.

Naam:

Straat:

land/postcode/plaats:

Telefoonnummer:

(voor vragen)

Artikel + kleur:

Reinigings- en onderhoudsinstructies

Gebruik voor het reinigen gewoon een zacht, vochtig doek. Gebruik nooit schuurmiddelen en / of oplosmiddelhoudende reinigingsmiddelen, aangezien deze het oppervlak kunnen krassen of beschadigen. Daarna dient het oppervlak te worden afgedroogd met een schoon, absorberend papier of doek. Op glanzende oppervlakken uitsluitend een zacht, katoenen doek gebruiken.

Reinigingsmiddelen die in geen enkel geval mogen worden gebruikt:



- Slijpende en schurende middelen, zoals schuurpoeder, schuursponzen met een ruwe kant of staalwol
- Polijstmiddelen, was- of bleekmiddelen, meubelreinigers
- Schoonmaakproducten met sterke zuren of heel zure zouten
- Stoomreinigingsapparaten

Montageinstructies



- Het meubel moet absoluut volgens de montageinstructies gemonteerd worden. Indien dit niet wordt gedaan, kan een onjuiste montage leiden tot functiestoornissen en blessurerisico's.
- De onderdelen op een zachte ondergrond monteren!
- Bijgevoegd bevestigingsmateriaal is enkel geschikt voor vast metselwerk! Alleen bevestigingsmateriaal gebruiken, dat geschikt is voor de betreffende muren. Indien nodig, informeert u zich het best op voorhand in de vakhandel.

  **1** = links

  **5** = Extra toebehoren

  **9** = Belangrijk: kantelbeveiliging

  **2** = rechts



  **6** = Korsjabloon



  **10** = Opgelet: Uitspringbeveiliging!

  **3** = boven

  **7** = Demontage van de deur

  **11** = Indien aanwezig met de hoekkast beginnen!

  **4** = vooraan

  **8** = Dit meubel moet aan de muur worden bevestigd.

Caro cliente,

Avete scelto un prodotto di qualità. Facciamo sempre del nostro meglio per soddisfarvi con una fornitura perfetta. Se tuttavia qualche elemento di ferramenta manca o è difettoso, vogliamo fornirvi al più presto per posta i ricambi mancanti.

Spuntate in modo inconfondibile nel vostro manuale di montaggio le parti da sostituire o rifornire ed informateci di seguito sul vostro indirizzo postale.

Nome:

Via:

Paese/CAP/città:

Tel. n.:

(per event.dom.di chiarim.)

Artic. + colore:

Avvert. per pulizia e la cura

Per pulire usare semplicemente un panno morbido, umido. Non usare mai prodotti per pulizia abrasivi e / o contenenti solventi, poiché possono graffiare o danneggiare le superfici. Asciugare la superficie con panni o strofinacci di carta assorbenti, puliti. In caso di superfici ultra-lucide usare esclusivamente panni di cotone morbidi.

Detergenti da evitare assolutamente:



- Mezzi levig. ed abras., come polv. abras., spugne per lucid. con lato ruvido o lana di acciaio
- Lucidante, detergente, lucido per mobili o decolorante
- Detergente con acidi forti e sali fortemente acidi
- Pulitori a vapore

Istruz. di mont.



- Il montaggio del mobile deve essere eseguito secondo le istruzioni. In caso di inosservanza, un errore di montaggio può causare danni, pregiudizio alle funzioni e lesioni personali.
- Montare le parti sing. solo su una base morbida!
- L'accluso materiale di fissaggio è idoneo solo per muratura resistente! Usare sempre materiale di fissaggio idoneo per le pareti interessate. Se necessario informarsi prima presso il commercio specializzato.



  **1** = sin.

  **5** = Accessori opzion.

  **9** = Import.: sic. antirib.



  **2** = des.

  **6** = Dima bulinatura

  **10** = Importante: osservare sicur.distacco!

  **3** = alto

  **7** = Smontaggio porta

  **11** = Se pres., iniziare dal mobile d'angolo!

  **4** = avan.

  **8** = Questo mobile deve essere fissato alla parete.

Milý zákazník,

Rozhodli jste se pro kvalitní produkt. Neustále se snažíme, dodat vám perfektní dodávku. V případě, že přesto chybí nějaký díl závěsu nebo je poškozen, poštou vám co nejrychleji nezbytné náhradní díly zašleme.

Zakroužkujte prosím zřetelně ve vašem montážním návodu díly, které se musejí vyměnit nebo dodat a zašlete nám vaši poštovní adresu.

Jméno:

Ulice:

Země/PSČ/město:

Telefonní číslo

(pro případné dotazy)

Druh + barva:

Pokyny pro čištění a údržbu

Na čištění používejte prosím měkký, vlhký hadřík. Nikdy nepoužívejte čisticí na drhnutí a/nebo s obsahem rozpouštědel. Tato mohou poškrabat či poškodit povrch. Povrch je třeba vysušit savými, čistými utěrkami nebo kapesníčky. U vysoce lesklých povrchů používejte prosím pouze bavlněné hadříky.

Čisticí prostředky, které se nikdy nesmějí používat:

- Brusné a čisticí prostředky na drhnutí, jako je brusný prášek, mycí houbičky hrubou stranou nebo ocelovou vlnou
- Lešticí prostředky, mycí prostředky, čisticí na nábytek nebo bělidla
- Čisticí prostředky se silnými kyselinami a vysoce kyselými solemi.
- Zařízení pro čištění parou

Montážní návody

- Montáž nábytku musí probíhat přesně dle montážního návodu. V opačném případě může chybná montáž vést k poškození, omezení funkčnosti a k nebezpečí poranění.

- Jednotlivé díly montujte pouze na měkký podklad!

- Přiložený upevňovací materiál je vhodný pouze pro pevné zdivo! Používejte vždy prosím pouze takový upevňovací materiál, který je pro dané stěny vhodný. V případě potřeby se informujte předem ve vašem odborném obchodě.



1 = vlevo



5 = Volitelné příslušenství



9 = Důležité: pojistka proti převrácení



2 = vpravo



6 = Šablona na otvory



10 = Důležité: Dbejte na pojistku proti vyštípnutí!



3 = nahoře



7 = Demontáž dveří



11 = Je-li k dispozici, začněte rohovou skříní!



4 = vpředu



8 = Tento kus nábytku je třeba upevnit na stěnu.

Уважаемый покупатель,

Вы выбрали высококачественное изделие. Мы всегда стараемся, чтобы вы были удовлетворены нашей безупречной поставкой. Если всё же отсутствует или дефектна деталь обшивки, то мы как можно быстро отправим вам почтой необходимую замену.

Чётко отметьте в инструкции по монтажу детали, которые нужно заменить или допоставить, и сообщите нам ваш почтовый адрес.

Наименование:

Улица:

Страна / индекс / город

Телефон №:

(для возможных вопросов)

Артикул + цвет:

Указания по чистке и уходу

Используйте для чистки просто мягкую, влажную ткань. Никогда не используйте абразивные и / или содержащие растворители чистящие средства, так как они могут оцарапать или повредить поверхности. Осушить поверхность чистым впитывающим полотенцем или бумажными салфетками. Для глянцевых поверхностей используйте только мягкие хлопчатобумажные ткани.

Чистящие средства, которые никогда нельзя применять:

- Абразивные и истирающие средства, такие как абразивные порошки, губки с шероховатой поверхностью или стальное волокно
- Полирующее, моющее, чистящее или отбеливающее средство
- Чистящие средства с сильными кислотами и сильно кислыми солями
- Устройства чистки паром

Инструкции по сборке

- Сборка мебели должна выполняться строго в соответствии с инструкцией по сборке. Неправильный монтаж может привести к повреждениям, функциональным нарушениям и к опасности травмирования.

- Монтировать отдельные детали только на мягкой основе!

- Прилагаемый крепёжный материал пригоден только для прочных кирпичных стен! Всегда применяйте такой крепёжный материал, который подходит для имеющихся стен. При необходимости лучше узнайте заранее в специализированной торговле.



1 = слева



5 = Опциональная принадлежность



9 = Важно: предохранение от опрокидывания



2 = справа



6 = Шаблон для разметки



10 = Важно: учитывайте защиту от выскакивания!



3 = вверху



7 = Демонтаж двери



11 = Если имеется, начинать с углового шкафа!



4 = спереди



8 = Этот предмет мебели должен крепиться на стене.

Уважаеми клиенти,

Избрали сте качествен продукт. Ние винаги се стремим да бъдете удовлетворени от безупречната ни доставка. Ако въпреки това някъде липсва обков или е повреден, искаме възможно най-бързо да ви изпратим резервната част с пощенска пратка.

Върху упътването за монтаж отбележете недвусмислено кои са частите за смяна или доставка и посочете след това пощенския си адрес.

Име:

Улица:

Държава / пощ. код / нас. място:

Тел. номер:

(за евентуални запитвания)

Артикул + цвят:

Указания за почистване и поддръжка



За почистване просто използвайте мека, влажна кърпа. Никога не използвайте абразивни и/или съдържащи разтворители почистващи препарати, защото повърхността може да се надраска или повреди. Повърхността трябва да се подсуши с попиващи, чисти кърпи за забърсване или хартиени кърпи. При силно гланцирани повърхности използвайте единствено меки памучни кърпи.



Почистващи препарати, които не трябва да се използват в никакъв случай:



- Шлифоващи и абразивни средства като пясък, гъби с груба страна или телчета
- Полиращи, миещи, почистващи мебели или избелващи препарати
- Почистващи препарати със силни киселини и силно кисели соли
- Паропочистващи уреди

Инструкции за монтаж

- При сглобяването на мебелите задължително трябва да се следва упътването. Ако не го следвате погрешният монтаж може да доведе до повреди, недобра функция и опасност от нараняване.
- Единични части се монтират само на мека основа!
- Приложените крепежни материали са подходящи само за твърд зид! Винаги използвайте крепежни материали, които са подходящи за съответните стени. При необходимост се информирайте предварително в специализиран магазин.

  **1** = наляво

  **5** = Опционални принадлежности

  **9** = Важно: Предпазител против преобръщане

  **2** = дясно

  **6** = Шаблон за центроване

  **10** = Важно: Внимавайте за предпазителя на прореза!

  **3** = горе

  **7** = Демонтаж на вратата

  **11** = Ако има ъглов шкаф, започнете от него!

  **4** = отпред

  **8** = Тази мебел трябва да се закрепва към стената.

Değerli Müşterimiz,

Üst düzey kaliteye sahip bir ürün tercih ettiniz. Daima sorunsuz bir teslimat yaparak sizleri memnun etmeyi amaçlıyoruz. Fakat buna rağmen bir sabitleme parçasında eksiklik veya bir kusur söz konusu olduğunda, gerekli parçaları size posta yoluyla en hızlı şekilde ulaştırıyoruz.

Montaj talimatınızda, değiştirilmesi veya ek olarak gönderilmesi gereken parçaları yanlış anlaşılacak bir şekilde çarpı işareti koyarak işaretleyin ve ardından bize posta adresinizi bildirin.

Adı:

Cadde:

Ülke / Posta kodu / Şehir:

Telefon no.

(muhtemel sorularınız için)

Ürün + Renk

Temizlik ve bakım uyarıları

Temizlik için lütfen sadece yumuşak, nemli bir bez kullanın. Yüzeyleri çizebilecekleri veya yüzeylere hasar verebilecekleri için lütfen aşındırıcı/çözücü madde içeren temizlik maddeleri kullanmayın. Yüzey; emici, temiz bir bez veya kağıt havlu ile kurulanmalıdır. Yüksek parlaklıktaki yüzeylerde lütfen sadece pamuklu bezler kullanın.

Kesinlikle kullanılmaması gereken temizlik maddesi:



- Aşındırıcı toz, bir tarafları sert temizlik süngerleri veya çelik yünü gibi aşındırıcı maddeler
- Cila, deterjan, mobilya temizleme maddesi veya ağartıcı
- Kuvvetli asitlere ve kuvvetli asit tuzlarına sahip temizlik maddesi
- Buharlı temizlik cihazı

Montaj talimatları



- Mobilya, mutlaka kurulum talimatına uygun şekilde kurulmalıdır. Aksi takdirde, yanlış bir bir montaj; hasara, fonksiyonların etkilenmesine ve yaralanma tehlikesine neden olabilir.
- Parçaları yumuşak bir altlık üzerinde monte edin!
- Birlikte verilen sabitleme malzemeleri sadece dayanıklı duvarlar için uygundur! Lütfen her zaman için ilgili duvar için uygun sabitleme malzemesini kullanın. Gerektiğinde, öncelikli olarak yetkili satıcınızdan bilgi alabilirsiniz.

  **1** = sol



  **5** = Opsiyonel aksesuar

  **9** = Önemli: Devrilme emniyeti



  **2** = sağ



  **6** = Sınırlama şablonu

  **10** = Önemli: Çıkış sigortasına dikkat edin!

  **3** = üst taraf

  **7** = Kapının sökülmesi

  **11** = Mevcutsa, köşe dolabı ile başlayın!

  **4** = ön taraf

  **8** = Bu mobilya parçası duvara tespit edilmelidir.

Szanowny Kliencie!

Zdecydowali się Państwo na produkt wysokiej jakości. Zawsze staramy się, by byli Państwo zadowoleni z jakości dostarczanych przez nas części. Jeżeli jednak mimo to jakiejś części okuciowej brakuje lub jest ona uszkodzona, chcemy najszybciej jak to możliwe wysłać ją Państwu pocztą.

Proszę jednoznacznie zaznaczyć w swojej instrukcji montażu części, które muszą zostać wymienione lub dodatkowo dostarczone w późniejszym terminie i podać nam adres pocztowy.

Nazwa:

Ulica:

Kraj / kod / miejsc.:

Nr telefonu

(w przypadku ewentualnych pytań)

Artykuł + kolor:

Wskazówki dotyczące czyszczenia i pielęgnacji



Do czyszczenia należy stosować miękką, wilgotną ściereczkę. Nigdy nie używać rysujących powierzchnię i/lub zawierających rozpuszczalniki środków czyszczących, ponieważ mogą one uszkodzić powierzchnię. Osuszyć powierzchnię chłonnymi, czystymi ściereczkami lub ręcznikami papierowymi. W przypadku powierzchni o wysokim połysku używać wyłącznie miękkich bawełnianych ręczników.

Środki czystości, których w żadnym przypadku nie wolno stosować:



- Środki powodujące ścieranie, np. proszki do szorowania, gąbki myjące z szorstką powierzchnią lub druciaki
- Środki polerujące, czyszczące, do czyszczenia mebli lub wybielające
- Środki czyszczące zawierające mocne kwasy i ich sole
- Urządzenia do czyszczenia parą wodną



Instrukcji montażu

- Składanie mebli należy wykonywać po kolei zgodnie z instrukcją obsługi. Nieprzestrzeganie instrukcji może prowadzić do nieprawidłowego montażu, uszkodzenia części, złego funkcjonowania oraz ryzyka zranienia.
- Pojedyncze części montować wyłącznie na miękkiej podstawie.
- Dołączony materiał mocujący nadaje się wyłącznie do użycia w litym murze. Należy zawsze stosować mat. mocujący, który jest przeznaczony do danego rodzaju ścian. W razie potrzeby zasięgnąć wcześniej informacji w sklepie branżowym.



  **1** = po lewej

  **5** = Opcjonalne akcesoria



  **9** = Ważne: zabezp. przed przewrót.



  **2** = po prawej



  **6** = Szablon do nawiercania

  **10** = Ważne: zwrócić uwagę na zabezpieczenie przed wyskoczeniem!

  **3** = wyżej

  **7** = Demontaż drzwi

  **11** = Jeżeli dotyczy, należy zaczynać od szafy narożnej!

  **4** = z przodu

  **8** = Ten mebel należy przymocować do ściany.

Spoštovani kupec,

Odložili ste se za kakovostni izdelek. Vedno se prizadevamo, da bi bili zadovoljni z dostavo naših izdelkov. Če kljub temu pride do poškodbe ali se pojavijo pomanjkljivosti, vam želimo kar najhitreje po pošti dostaviti ustrezen nadomestni del.

V navodilih za montažo označite dele, ki jih je treba zamenjati ali dopolniti in ne pozabite navesti vašega točnega naslova.

Ime:

Ulica:

Država / poštna številka / kraj:

Tel. št.:

(za morebitna vprašanja)

Izdelek + barva:

Nasveti za čiščenje in nego

Prosimo, za čiščenje uporabljajte samo mehko, rahlo navlaženo krpo. Ne uporabljajte grobih čistil in/ali topil, ker lahko razpraskajo in poškodujejo površino. Površino do suhega obrišite z vpijajočo papirnato brisačo. Na svetlečih površinah čistite izključno samo z mehкими bombažnimi krpami.



Čistila, ki jih v nobenem primeru ne smete uporabljati:



- Groba čistila ali topila, kot so brusne paste, čistilne krpice z grobo stranjo ali jeklena volna
- Polirno sredstvo, pralno sredstvo, čistilo za pohištvo, belilo
- Čistila z močnimi kislinami in močno kislo soljo
- Parni čistilnik

navodilu za sestavo

- Pohištvo je potrebno sestaviti po podatkih, ki so v navodilih za sestavo. Neupoštevanje navodil za sestavo lahko povzroči napačno montažo, poškodbe pohištva, omejene funkcije in telesne poškodbe
- Posamezne dele sestavljajte samo na mehki podlagi!
- Priloženi pritrdilni material je namenjen samo za trden zid! Prosimo, vedno uporabljajte pritrdilni material, ki je primeren za uporabljeno steno. O tem se lahko predhodno informirate tudi v prodajalni.

  **1** = levo

  **5** = Dodatna oprema



  **9** = Pomembno: Varovanje pred prevrnitvijo

  **2** = desno

  **6** = Šablona za točkanje

  **10** = Pomembno: Upoštevajte izkočno varovalko!

  **3** = zgoraj

  **7** = Odstranitev vrat

  **11** = Če obstaja, začnite s kotno omaro!

  **4** = spredaj

  **8** = To pohištvo je potrebno pritrditi na steno.

Vážený zákazník,

Rozhodli ste sa pre kvalitný výrobok. Stále sa snažíme, aby sme Vás uspokojili bezchybnou dodávkou. Ak by aj napriek tomu chýbal alebo bol poškodený diel kovania, chceme Vám v čo najkratšom čase poštovou zásielkou poskytnúť nevyhnutné náhradné diely.

V návode na montáž jasne krížikom označte diely, ktoré musia byť nahradené alebo dodané a informujte nás ďalej o Vašej poštovej adrese.

Názov:

Ulica:

Krajina / PSČ / Miesto

Č. telefónu:

(pre prípadné otázky)

Výrobok + farba:

Pokyny pre čistenie a ošetrovanie

Pri čistení použite prosím jednoducho mäkkú, vlhkú handru. Nikdy prosím nepoužívajte abrazívne čistiace prostriedky a/alebo čistiace prostriedky s obsahom rozpúšťadiel, pretože tieto môžu povrch poškríbať alebo poškodiť. Povrch dosušte savou, čistou handričkou alebo papierovou utierkou. Pri vysokolesklých povrchoch použite prosím výlučne len mäkké bavlnené handry.

Čistiace prostriedky, ktoré nesmiete za žiadnych okolností použiť:

- Brúsiace a abrazívne čistiace prostriedky, napr. prášok na drhnutie, čistiace hubky s drsnou stranou alebo oceľová vlna
- Leštiaci prostriedok, čistiaci prostriedok, prostriedok na čistenie nábytkov alebo bielin
- Čistiace prostriedky so silnými kyselinami a silnými soľami kyselín
- Zariadenia na čistenie parou

Pokyny na montáž



- Montáž nábytku musíte bezpodmienečne vykonať podľa montážneho návodu. Pri jeho nedodržaní môže chybná montáž mať za následok poškodenie, obmedzenie funkčnosti a riziko poranenia.
- Samostatné diely montujte len na mäkkom podklade!
- Priložený upevňovací materiál je určený len pre pevné murivo! Používajte vždy upevňovací materiál, ktorý je určený pre príslušné steny. Ak je to nevyhnutné informujte sa, najlepšie vopred, v špecializovanej predajni.



1 = vľavo



5 = Alternatívne príslušenstvo



9 = Dôležité: Zabezpečenia proti preklopeniu



2 = vpravo



6 = Jamkovácia šablóna



10 = Dôležité: Venujte pozornosť vyskakovacej poistke!



3 = hore



7 = Demontáž dverí



11 = Ak existuje, začnite rohovou skriňou!



4 = vpredu



8 = Tento kus nábytku musíte pripevniť na stenu.

Kedves Vevőnk!

Őn egy minőségi termék megvétele mellett döntött. Szüntelenül azon fáradozunk, hogy kifogástalan szállítással elégedetté tegyük Önt. Ha netán mégis hiányozna, vagy hiányos lenne egy vasalás, postai úton a leggyorsabban eljuttatjuk Önnek a szükséges pótalkatrészeket.

Jelölje be a szerelési utasításban a lecserélendő, vagy utólag szállítandó alkatrészeket, és közölje velünk a levélcímét az alább módon.

Név:

Utca:

Orsz. / ISZ / helység:

Telefonsz.:

(esetleges kérdések esetén)

Termék + szín:

Tisztítási és ápolási tanácsok

A tisztításhoz egyszerűen puha, nedves kendőt használjon. Soha ne használjon súroló és / vagy oldószer tartalmú tisztítószerrel, mivel ezek összekarcolhatják, vagy megrongálhatják a felületeket. Nedvszívó, tiszta töröl- vagy papír kendővel utólag törölje szárazra a felületet. Tükörfényes felületeknél kizárólag puha pamutkendőket használjon.

Tisztítószereket semmi esetre sem szabad használni:

- Csiszoló és polírozó anyagok, például súrolószer, tisztítószivacs durva oldala, vagy acélgyapot
- Polírozószer, mosószer, bútortisztító vagy fehérítőszer
- Tisztítószer erős savakkal és erősen savanyú sókkal
- Gőzös tisztítókészülékek

Szerelési utasítások



- A bútort az összeállítási útmutató alapján kell összeállítani. Ha nem így tesz, a helytelen szerelés rongálódásokhoz, működési zavarokhoz és sérülésveszély kialakulásához vezethet.
- Az alkatrészeket csak puha aljon szabad összeszerelni!
- A mellékelt felerősítő anyag csak szilárd falon használható! Mindig olyan felerősítő anyagot használjon, amely szóba jöhet az illető falon. Szükség esetén előre tájékozódjon a szaküzletben.



1 = balos



5 = Rendelhető tartozék



9 = Fontos! Eldőlés gátló



2 = jobbos



6 = Központozó sablon



10 = Fontos! A kiugrásvédőre figyeljen!



3 = fenn



7 = Az ajtó leszerelése



11 = Ha van, kezdje a sarokszekrényvel!



4 = elől



8 = A bútordarabot a falon kell rögzíteni.

Stim. client,

V-ați decis să achiziționați un produs de calitate. Facem în permanență eforturi pentru a vă oferi și o livrare ireproșabilă. Dacă se întâmplă totuși ca vreun fitting să lipsească sau să prezinte deficiențe, vă vom trimite în cel mai scurt timp, prin poștă, o piesă de schimb.

În instrucțiunea de montaj, bifați fără posibilitate de eroare piesele care trebuie înlocuite sau livrate ulterior și puneți-ne apoi la dispoziție adresa dvs. de corespondență.

Den.:

Strada:

Țară/Cod p./Loc.:

Nr. telefon: (pt. eventuale întrebări)

Art. + culoare:

Instrucț. de curăț. și îngrij.

Pentru curățare folosiți o cârpă moale, umedă. Nu folosiți niciodată mijloace de curățare abrazive și/sau cu conținut de solvenți, deoarece acestea zgârie suprafețele sau le pot deteriora. Suprafața trebuie uscată cu lavete textile sau de hârtie, absorbante și curate. În cazul suprafețelor cu luciu se vor utiliza exclusiv lavetele moi din bumbac.

Agenți de curățare a căror utilizare este strict interzisă:



- Materiale abrazive sau de șlefuit: pulbere abrazivă, bureți cu o parte ruгоasă sau metalici
- Ag. de lustr., deterg., ag. de curățare mobilă sau înălbitor
- Agent de curățare cu acizi tari și săruri puternice
- Disp. curăț. cu abur

Instr. de montaj



- Montarea mobilei trebuie efectuată conform instrucțiunilor. În cazul nerespectării, un montaj necorespunzător poate conduce la deteriorări, probleme de funcționare și pericol de accidentare.
- Piesele indiv. se mont. doar pe substrat moale!
- Materialul de fixare atașat este numai pentru zidăria rezistentă! A se utiliza întotdeauna materiale potrivite pentru pereți. În caz de nevoie informați-vă în prealabil în comerțul de specialitate.



  **1** = stg.

  **5** = Accesoriu opțional



  **9** = Imp.: Sig. anti-basc.



  **2** = drpt.

  **6** = Șabl. mar. cen.

  **10** = Important: Atenție la sig. de ieșire!

  **3** = sus

  **7** = Demontarea ușii

  **11** = Unde este caz., încep. cu unit. de colț!

  **4** = față

  **8** = Acest articol de mobilier trebuie fixat pe perete.

A460/A461/A462				
A		DU 279	918377	8x
B			87115	8x
C		6,3x11 mm	674105	8x
D		3,5x17 mm	1136159	8x
E		∅18 mm	1248105	4x
F		∅7 x 33,5 mm	721030	8x
G		∅15 mm	632123	8x
H		DU 712	252975	4x
J			87453	16x
K			918380	8x

A4/A321				
L		M6x25 mm	1248106	8x
M		∅5 mm	418562	12x
N			918379	16x
O		4,0x50 mm	309000	16x

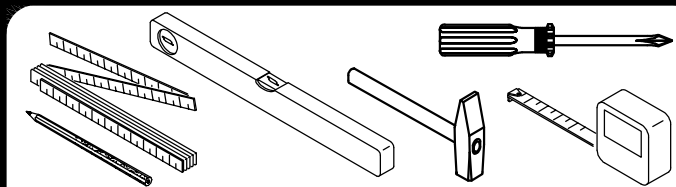

1

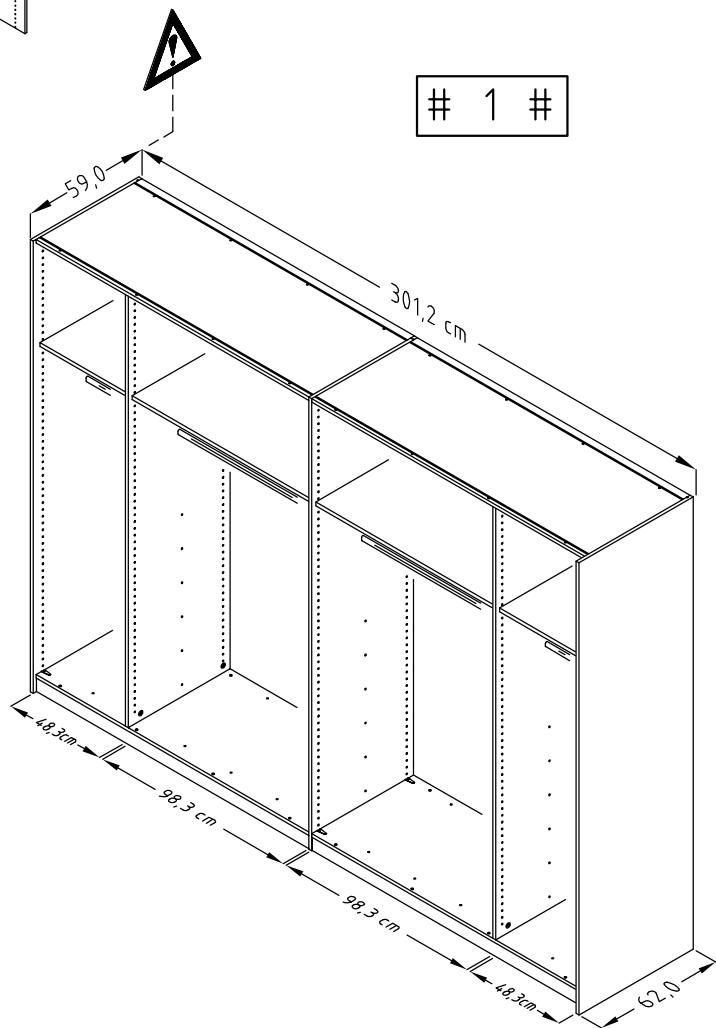
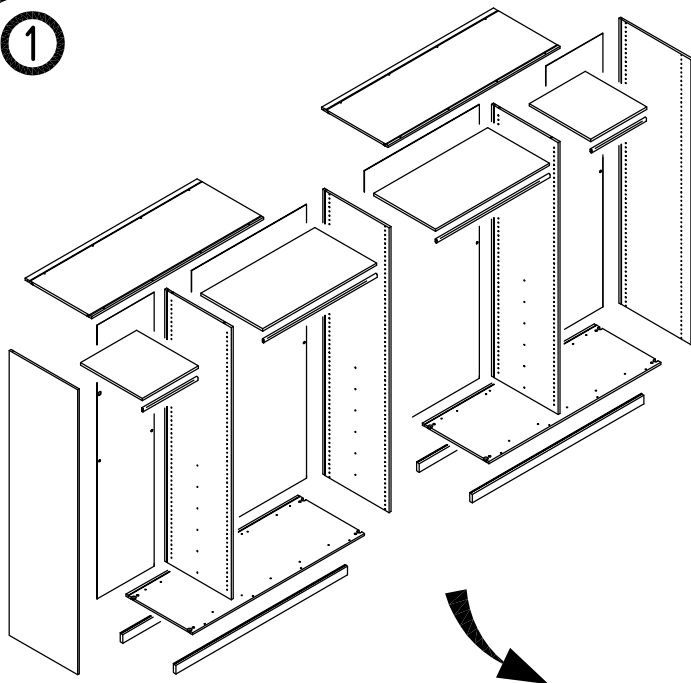

1

1

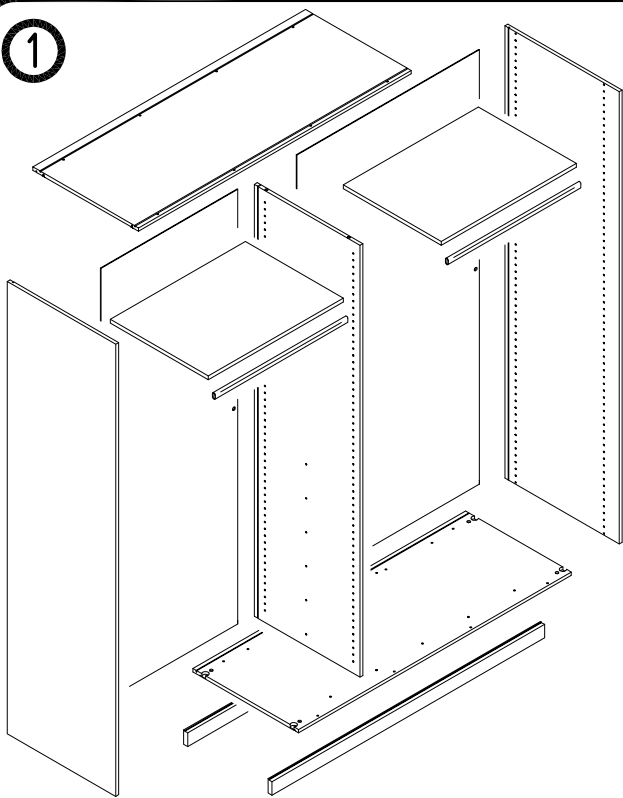

2

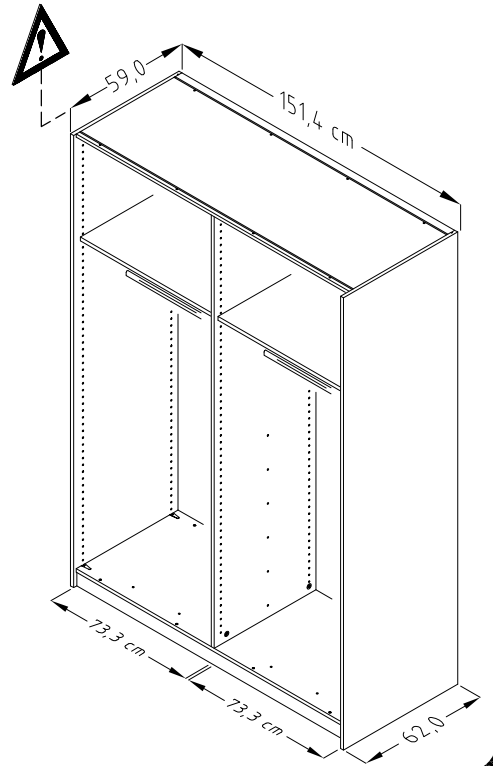

2

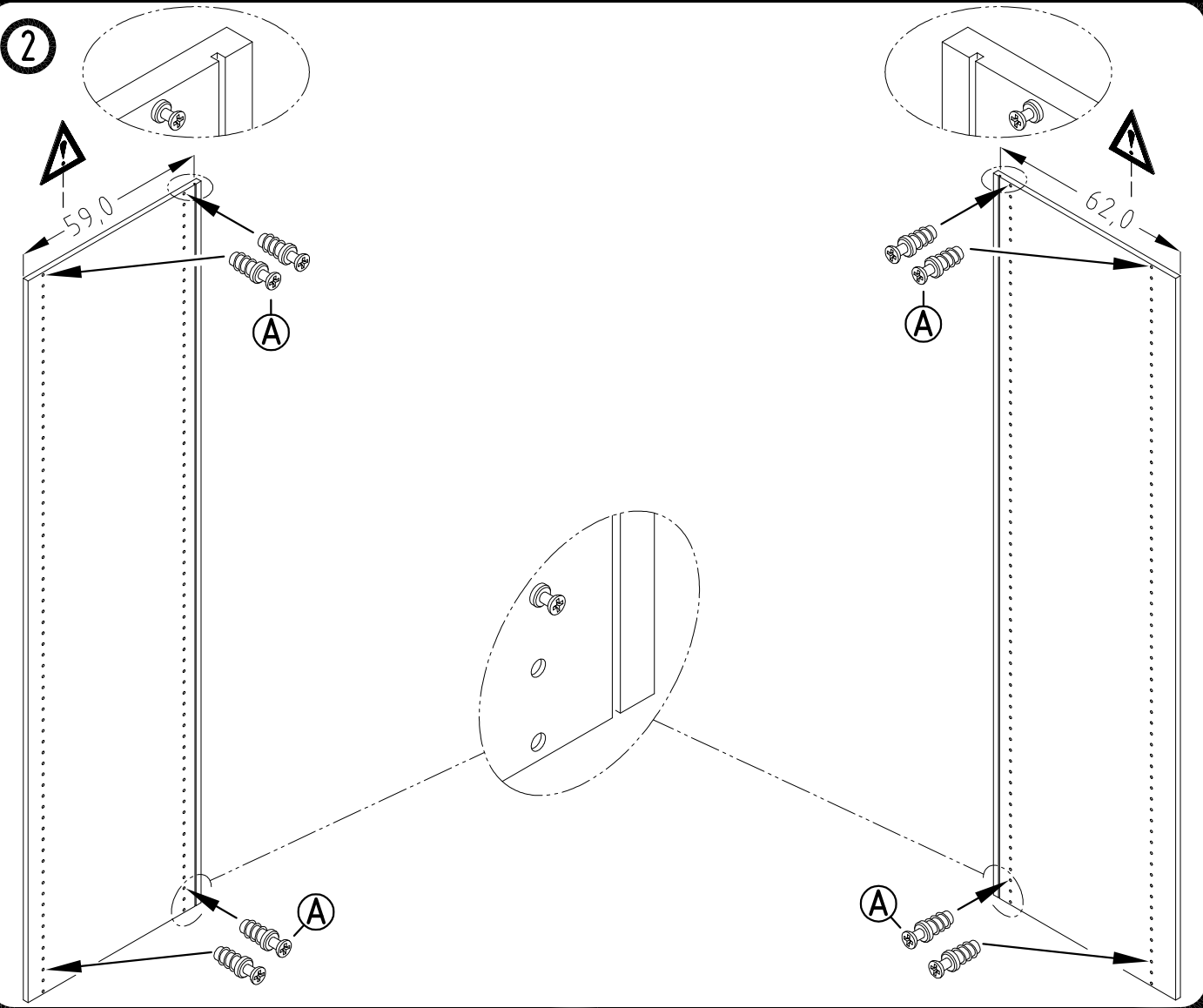

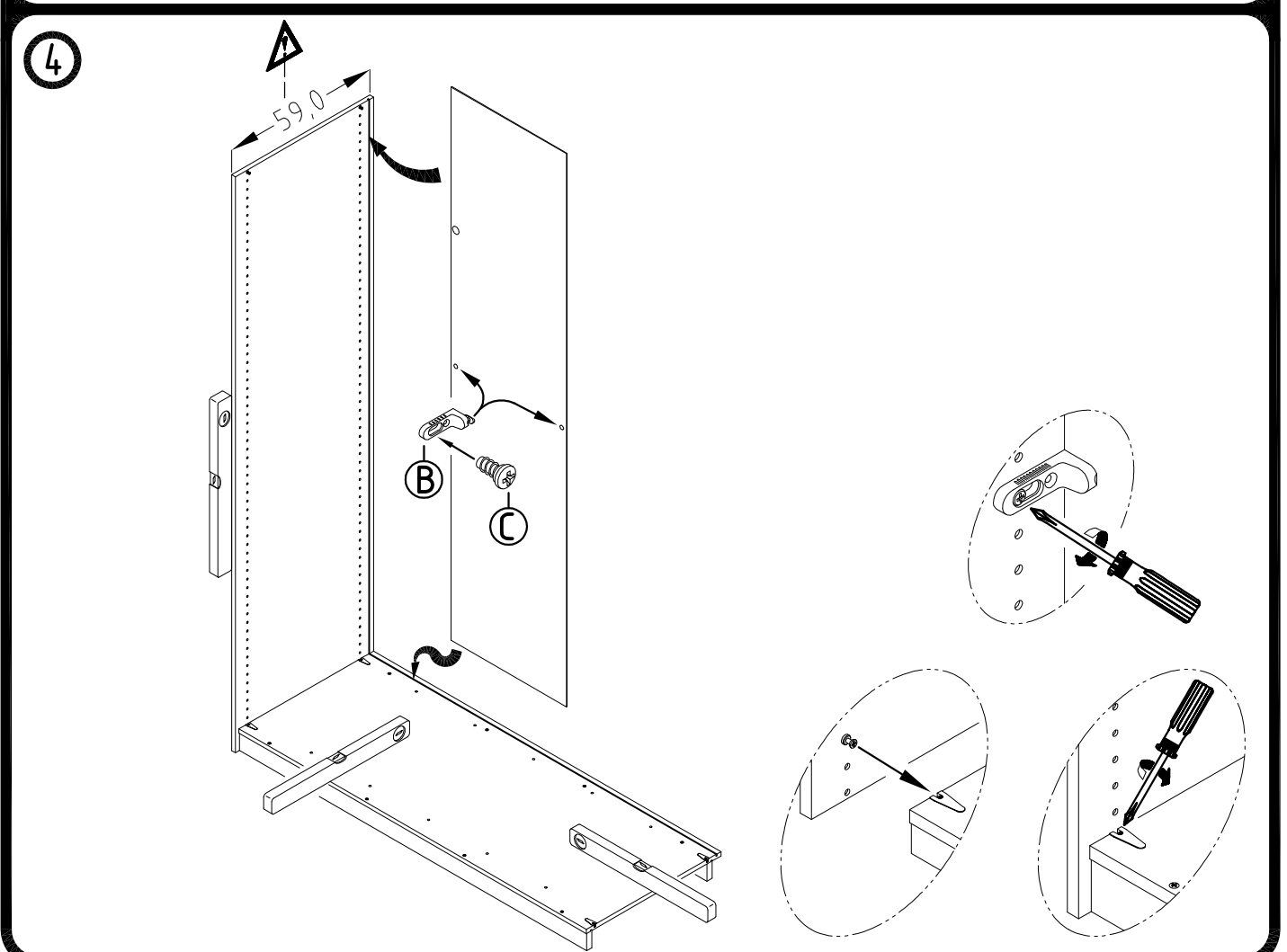
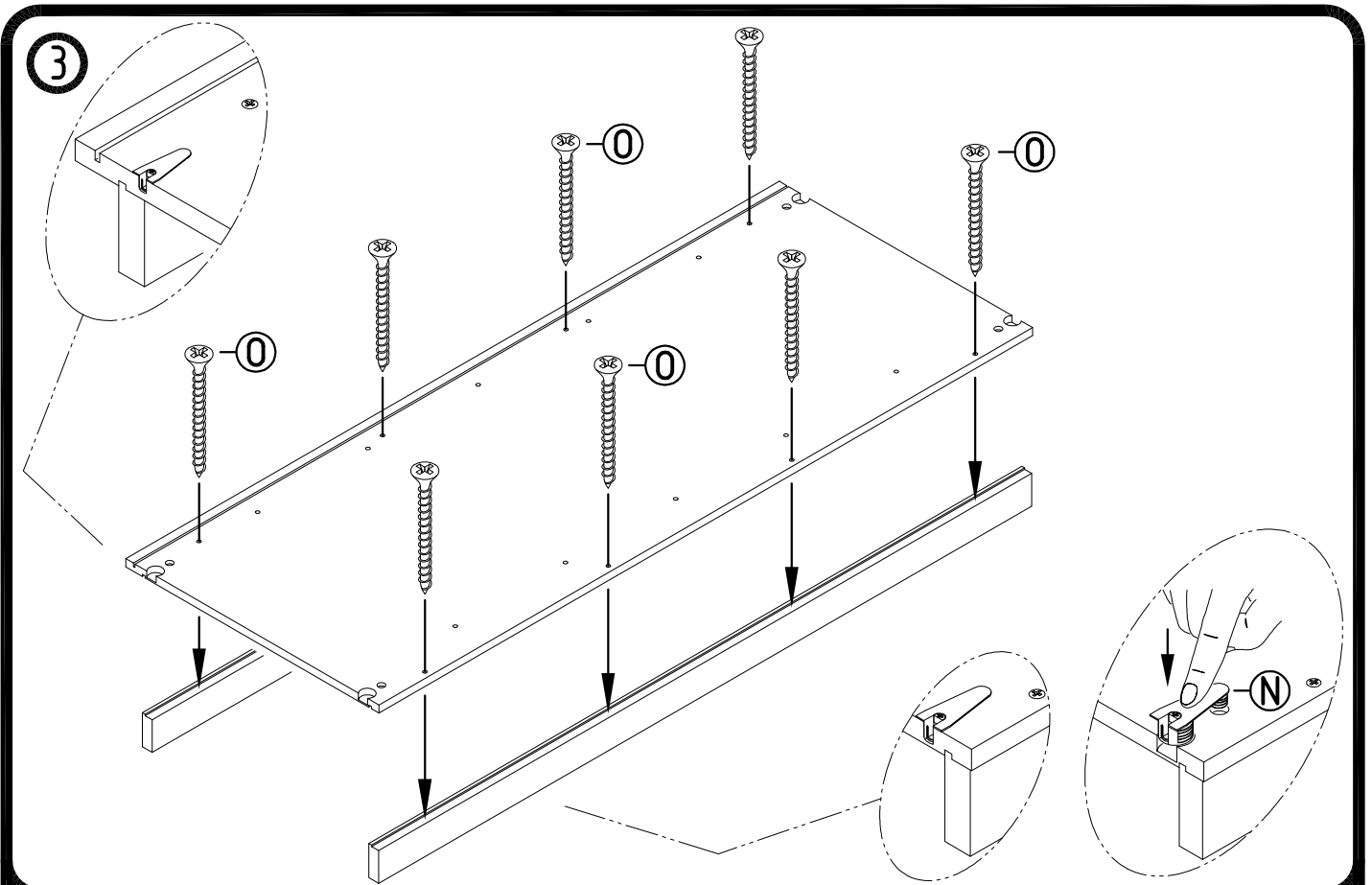

5

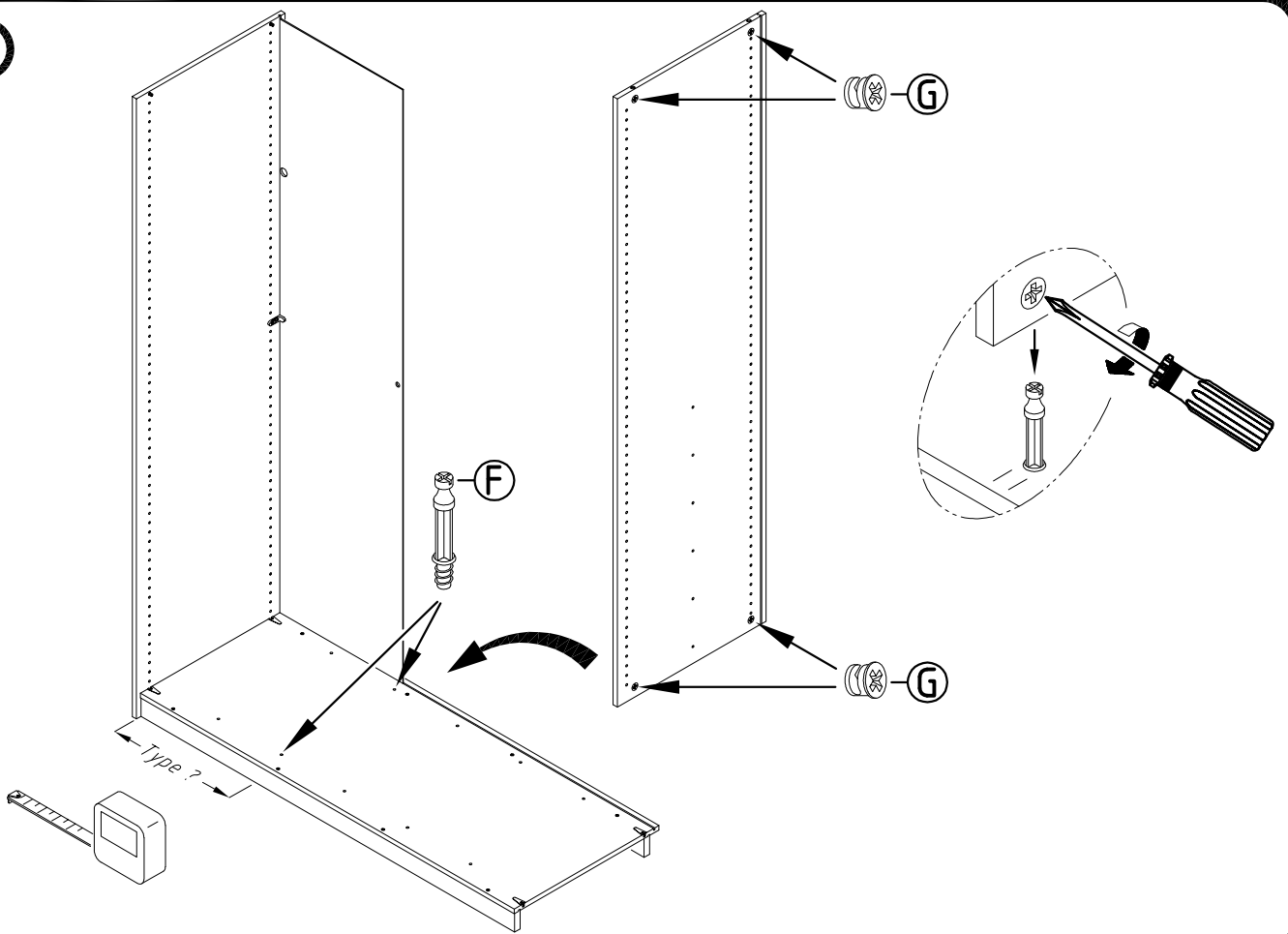

6

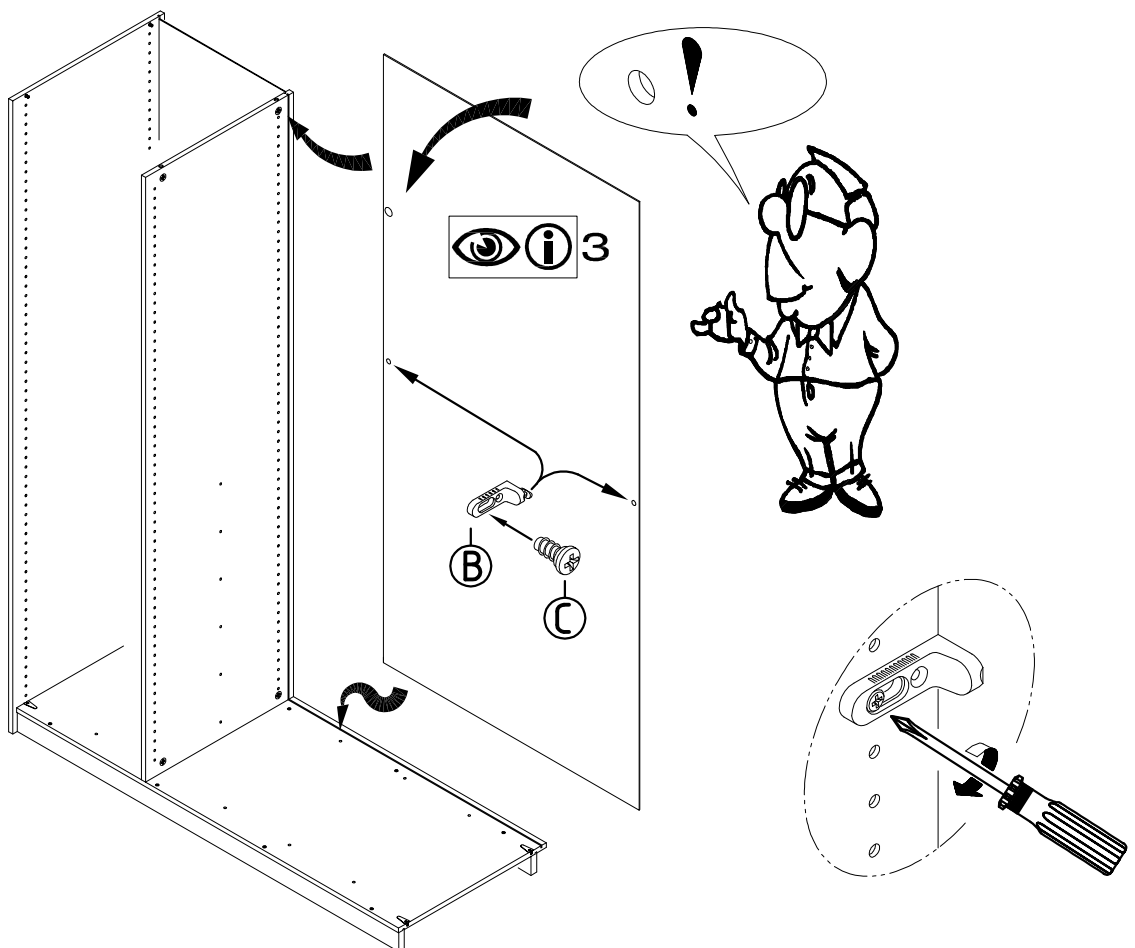

7

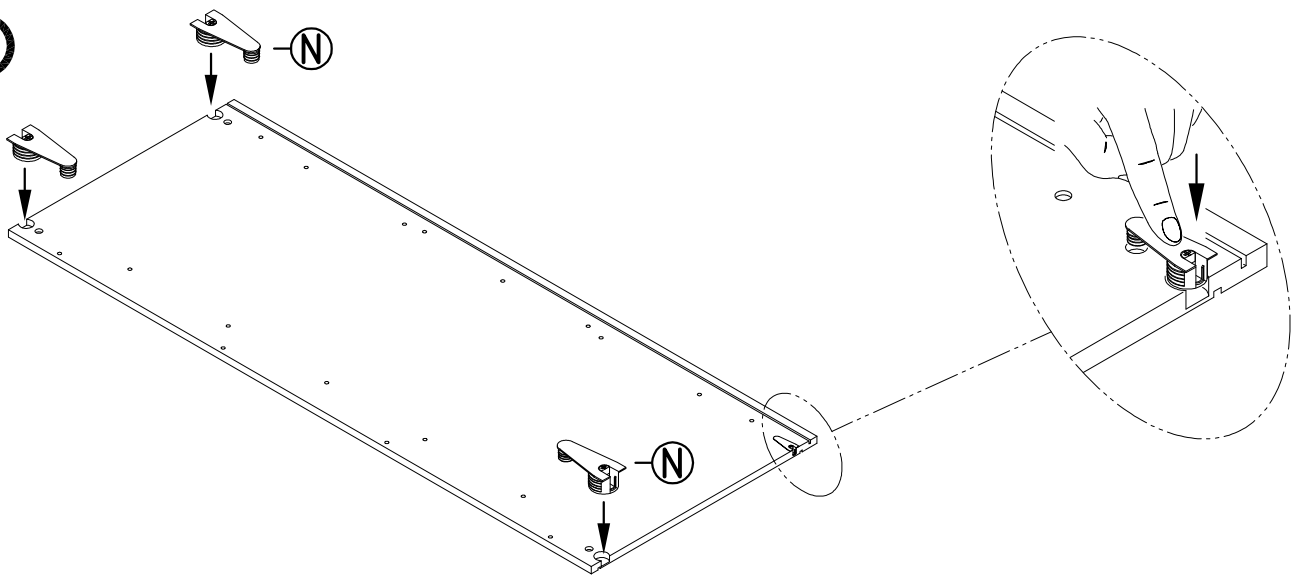

8

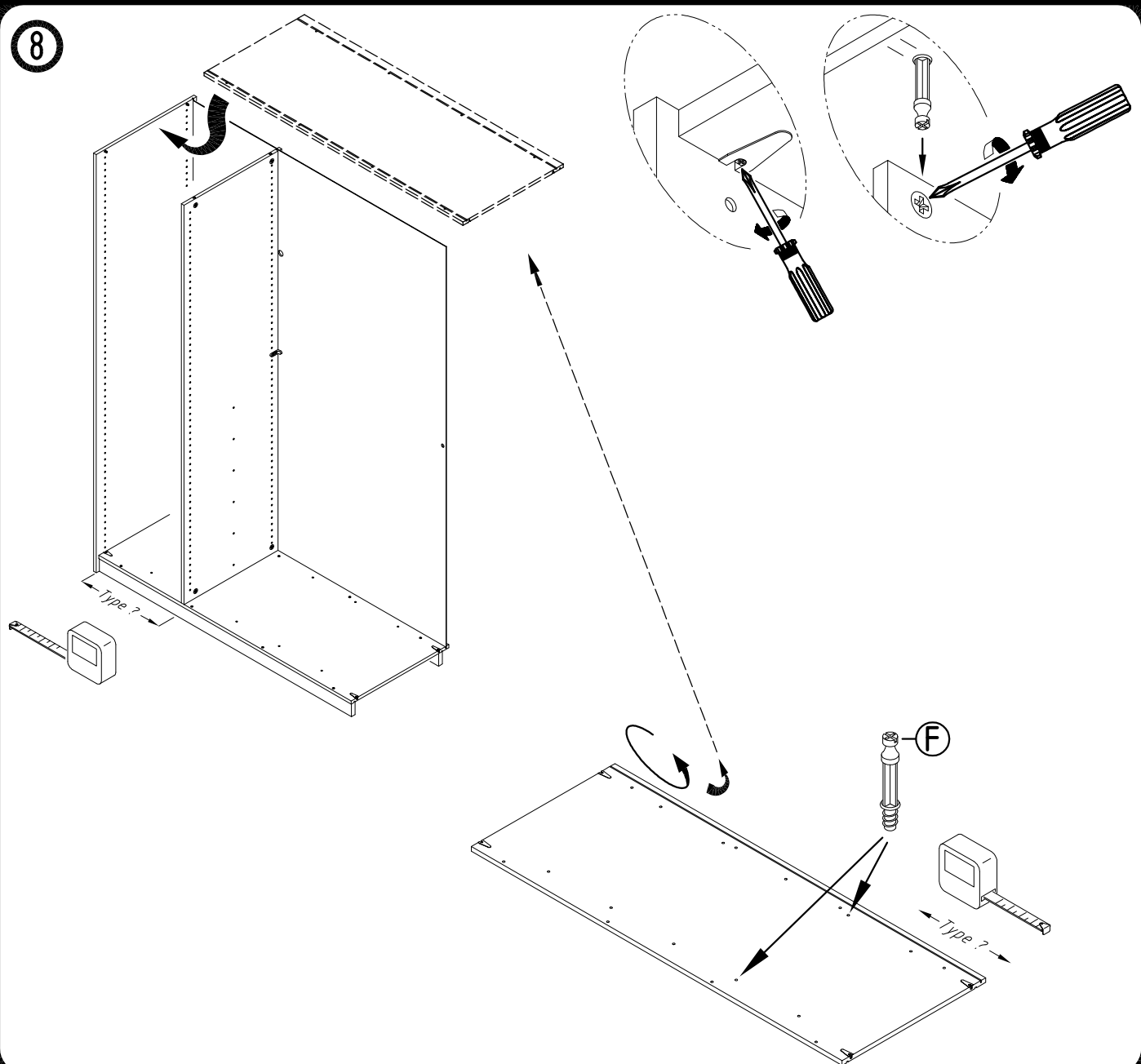

9

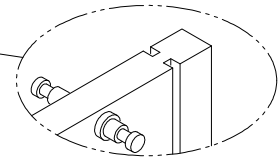
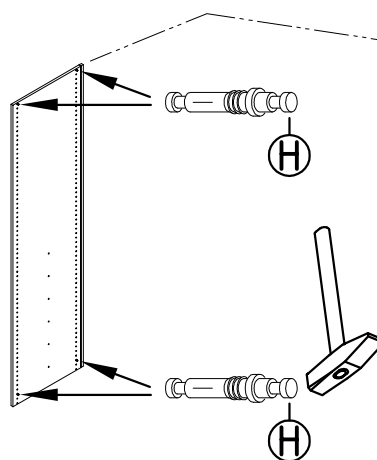
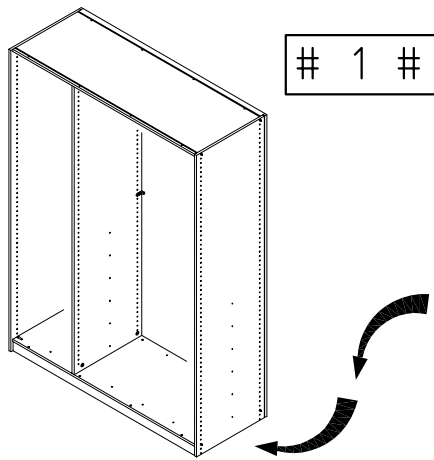
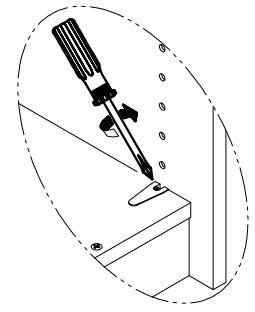
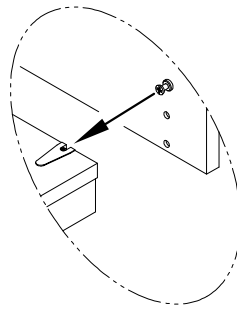
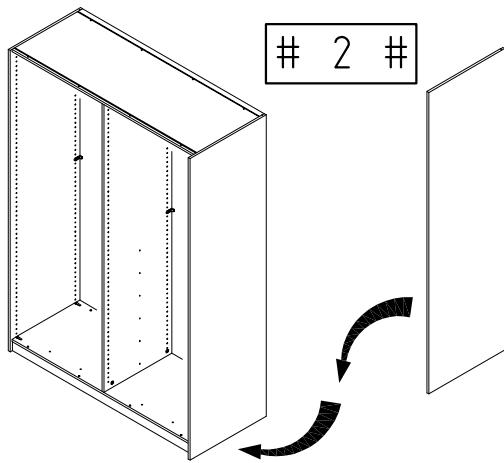

10

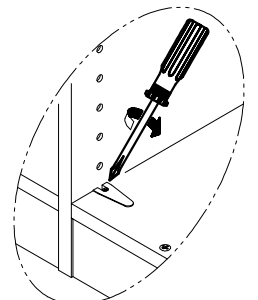
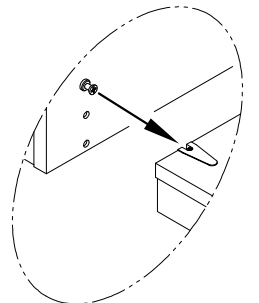
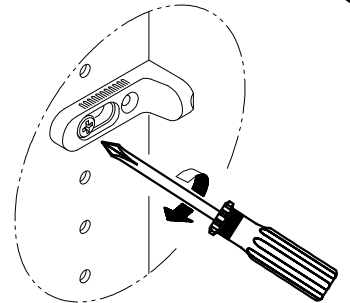
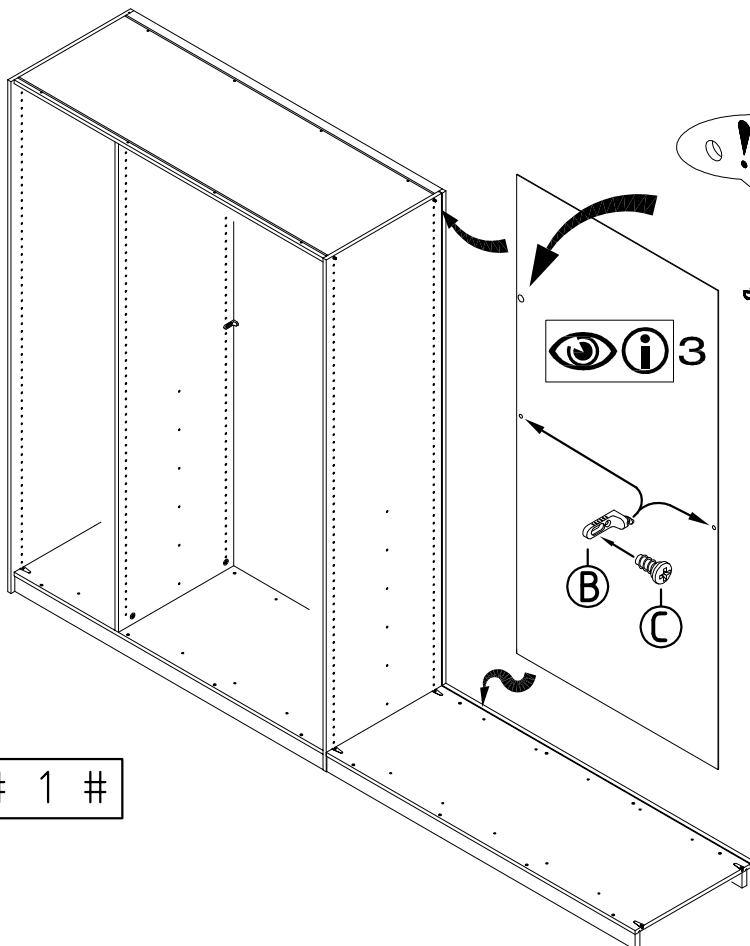

11

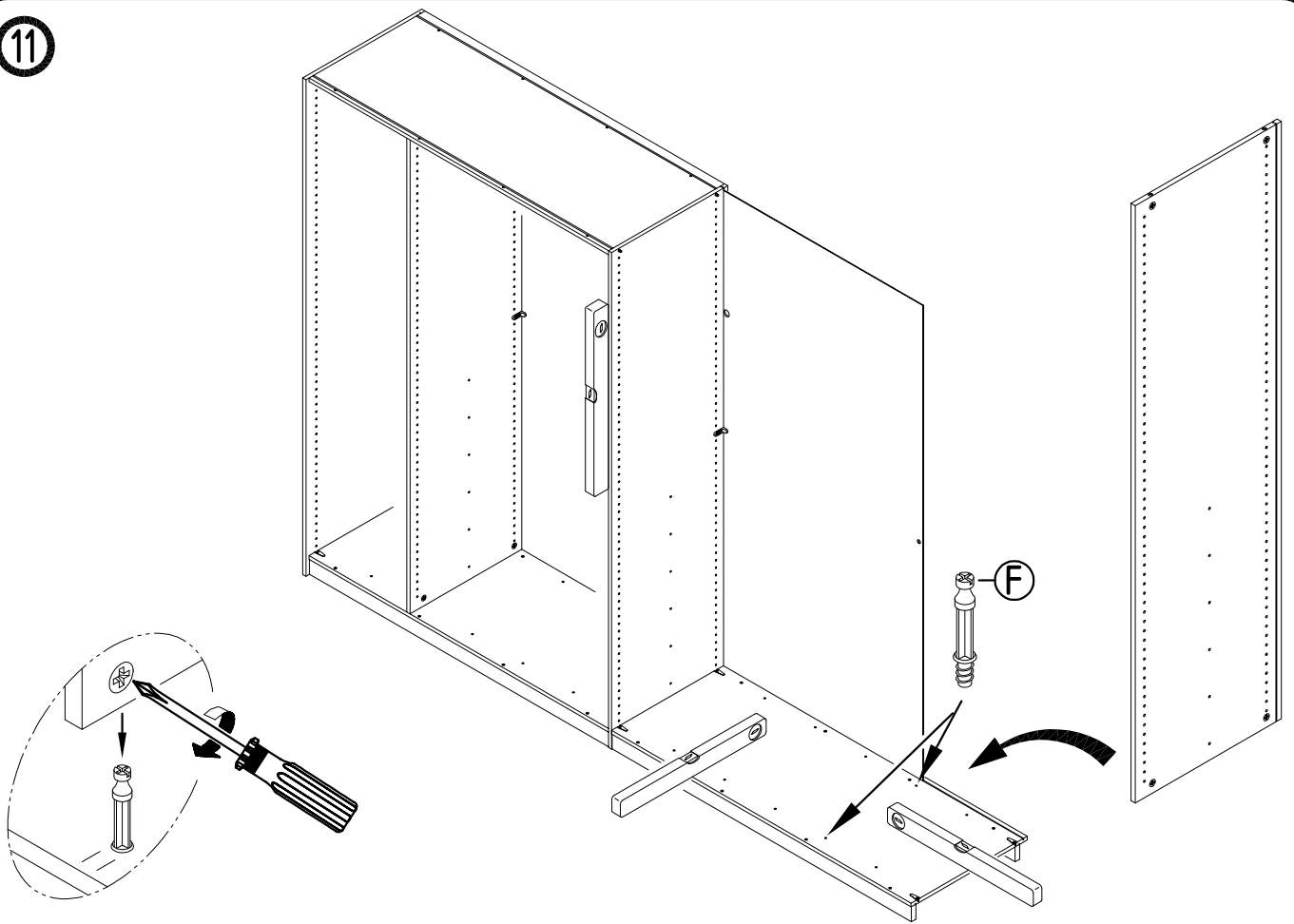

12

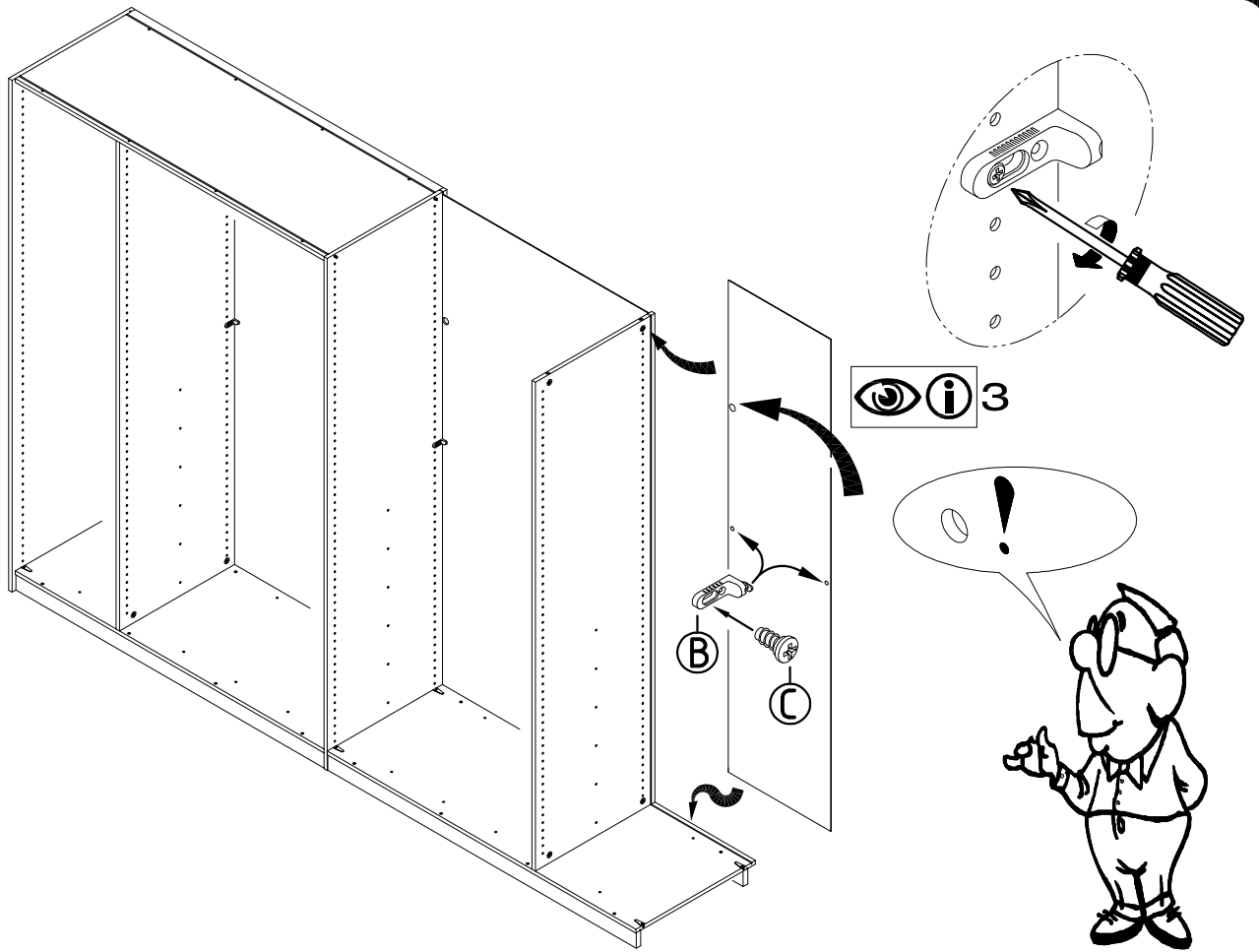

13

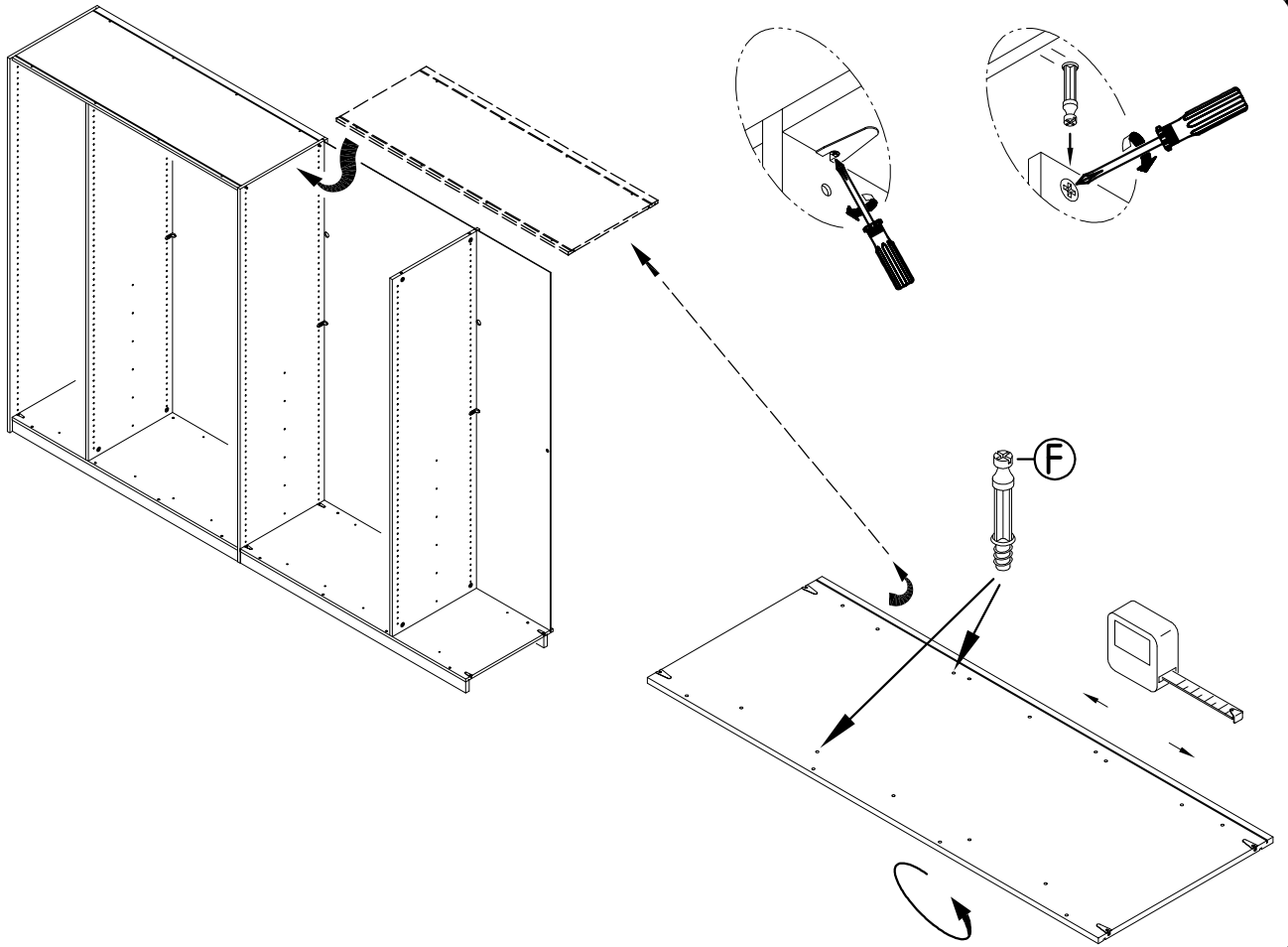

14

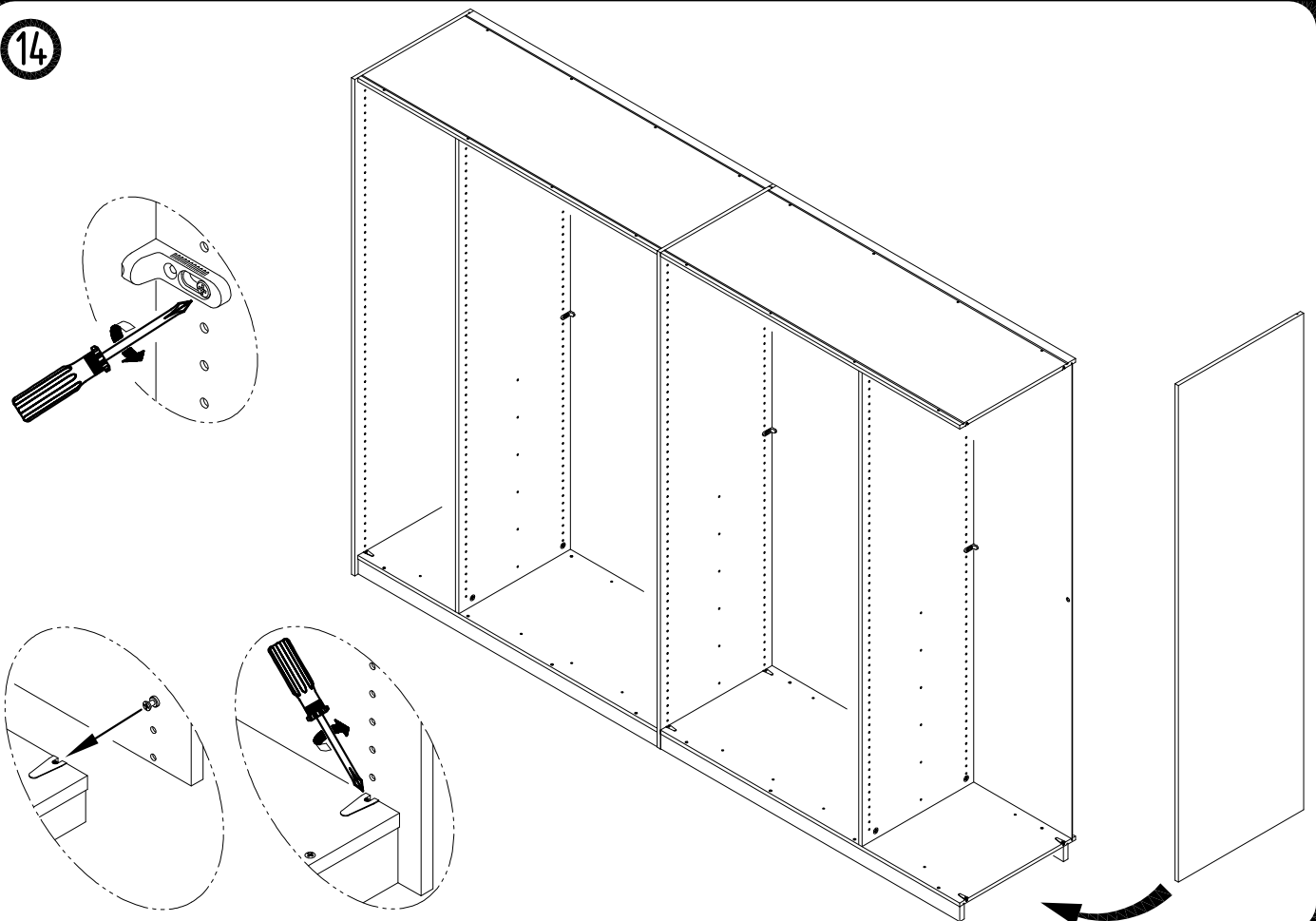

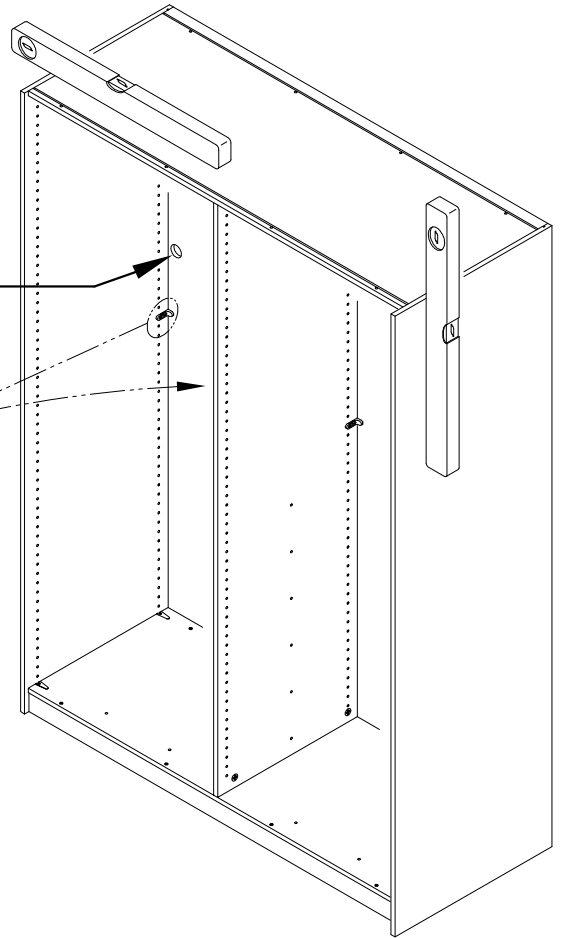
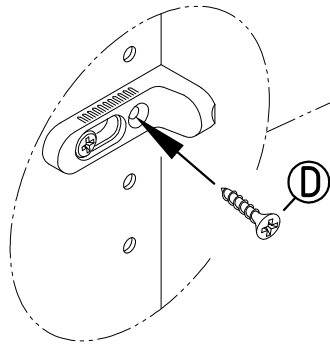
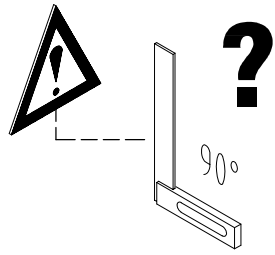

15

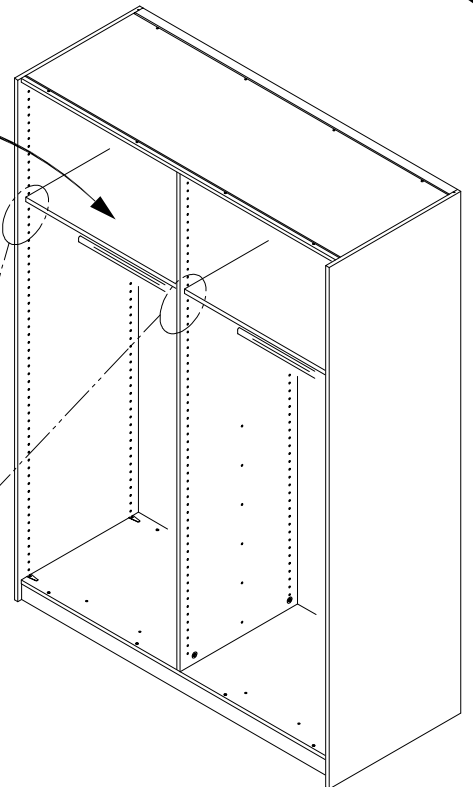
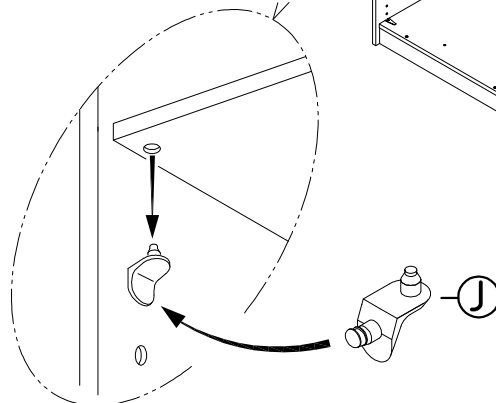
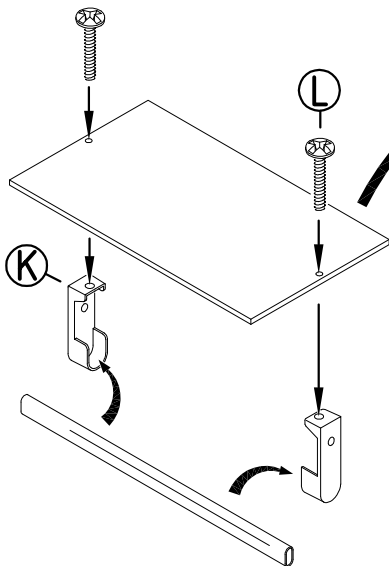

16

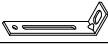

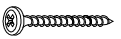
A2		100x28x16	2x
B2		∅8	2x
C2		4,5x17	4x
D2		5,0x50	2x

