



NOTICE DE MONTAGE

FOLHA DE MONTAGEM

ASSEMBLY INSTRUCTION

AVVERTENZA PER IL MONTAGGIO

AUFBAUANLEITUNG

ИНСТРУКЦИЯ ПО СБОРКЕ

INSTRUCCIONES DE MONTAJE

安装手册

MONTAGE HANDLEIDING



ligne design

# VOLTA

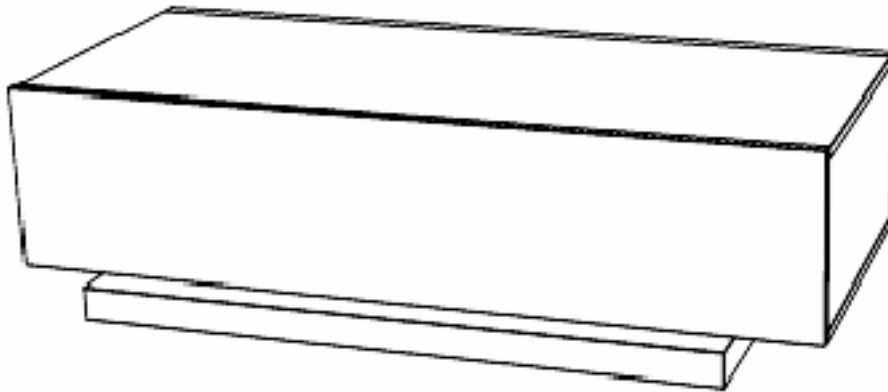

**VOLTA 41 BANC TV HIFI 1 ABATTANT N°6 Réf: 10ST3310**

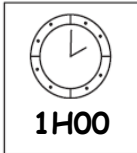
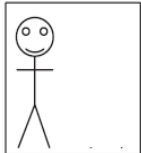

OUTILLAGES TOOLS HANDWERKZEUGE HERRAMIENTA GEREEDSCHAP

FERRAMEN

ATTREZZATURE

ИНСТРУМЕНТЫ ДЛЯ СБОРКИ 工具

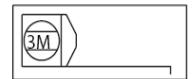
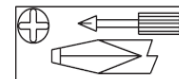
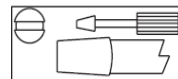
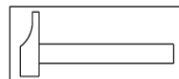
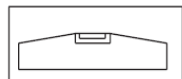

**F** POUR L'APRES-VENTE, RETOURNEZ AU MAGASIN AVEC CETTE NOTICE

**GB** FOR THE AFTER SALES, GO BACK TO THE SHOP WITH THIS ASSEMBLY INSTRUCTION

**D** WENDEN SIE SICH BITTE AN IHREN HANDLER UND GEBEN SIE IHM DIE KENNUMMER DES MOBELS UND DIE TEILNUMMER

**E** EN CASO DE SERVICIO POST-VENTA DEBEN DE VOLVER A LA TIENDA CON LAS INSTRUCCIONES DE MONTAJE

**NL** VOOR SERVICE NA VERKOOP, GA NAAR UW LEVERANCIER MET DEZE MONTAGE HANDLEIDING

**P** PARA O POS VENDA, VOLTE A LOJA COM ESTA FOLHA

**I** SERVIZIO POST VENDITA: E NECESSARIO PRESENTARSI SUL PUNTO VENDITA CON QUESTE ISTRUZIONI DI MONTAGGIO

**RU** ДЛЯ ПОСЛЕПРОДАЖНОГО ОБСЛУЖИВАНИЯ ПРОСЬБА ОБРАТИТЬСЯ В МАГАЗИН, ПРЕДЪЯВИВ НАСТОЯЩУЮ ИНСТРУКЦИЮ ПО СБОРКЕ.

**CN** 请求售后服务时, 请带好该手册找到当地的商店

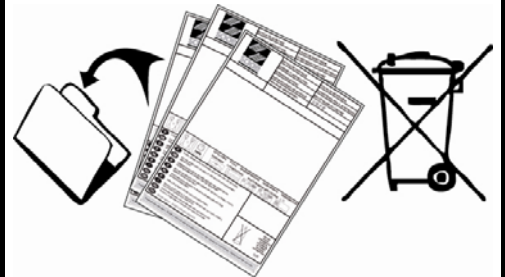

# NO

SOLVANT  
DILUANT  
LÖSUNGSMITTEL  
SLOVENTE  
OPLOSMIDDEL  
OF THINNER  
SOLVENTE  
РАСТВОРИТЕЛЬ

溶剂

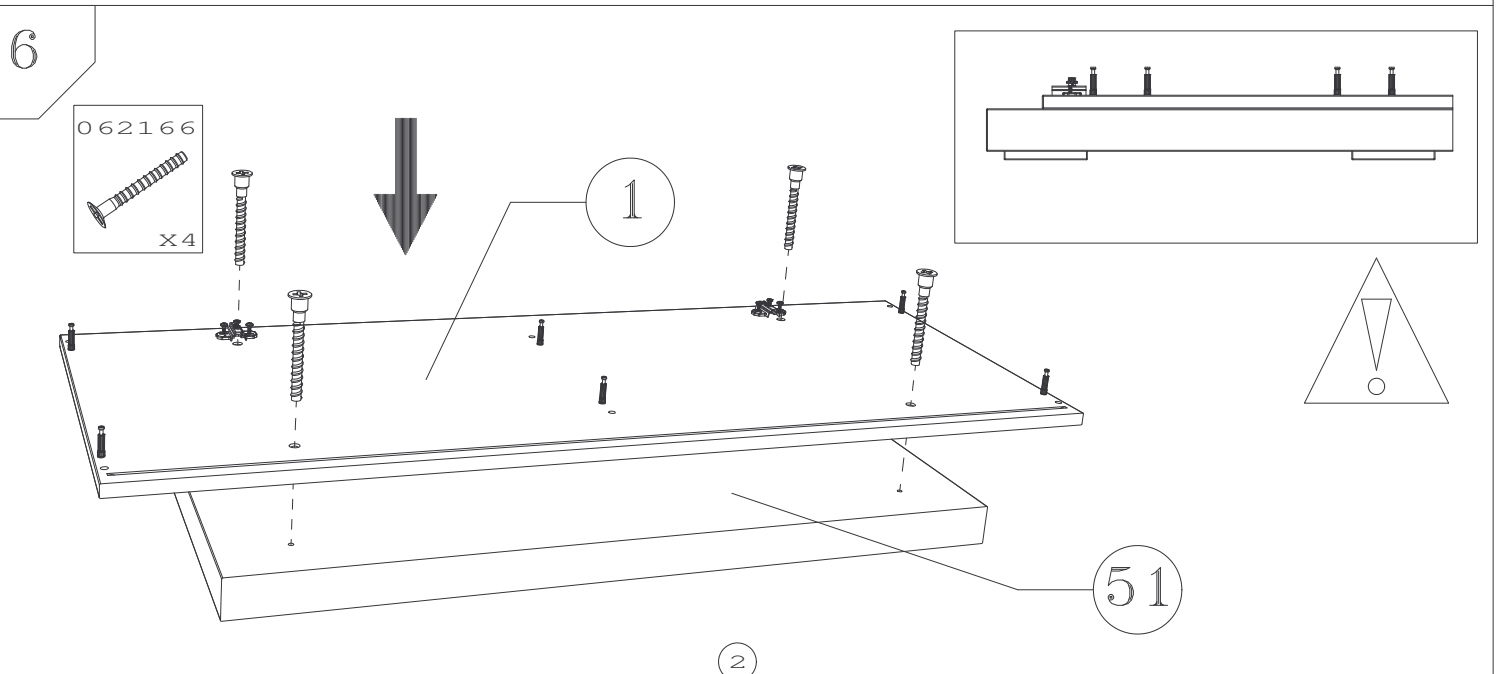
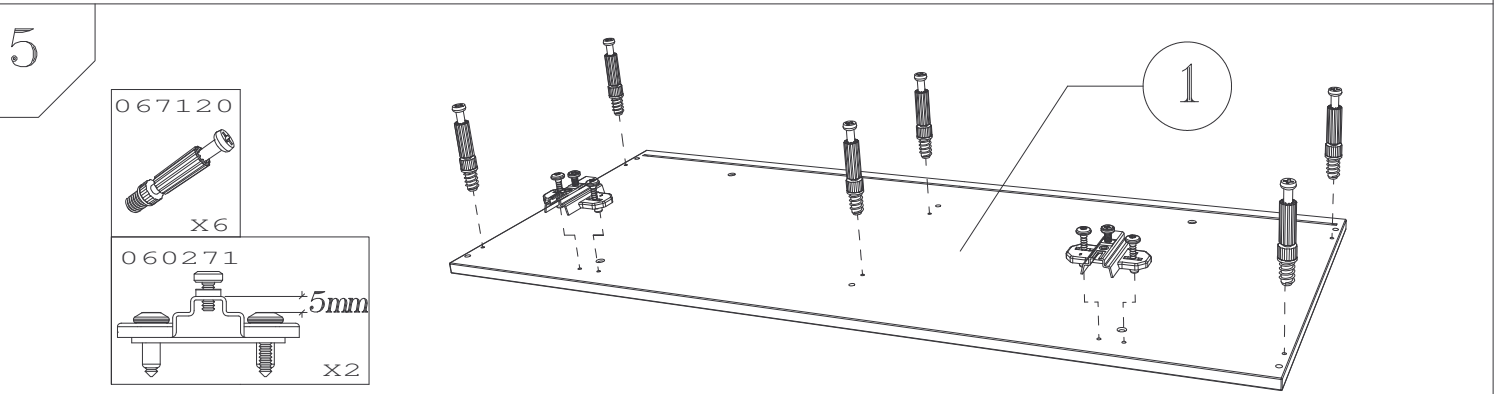
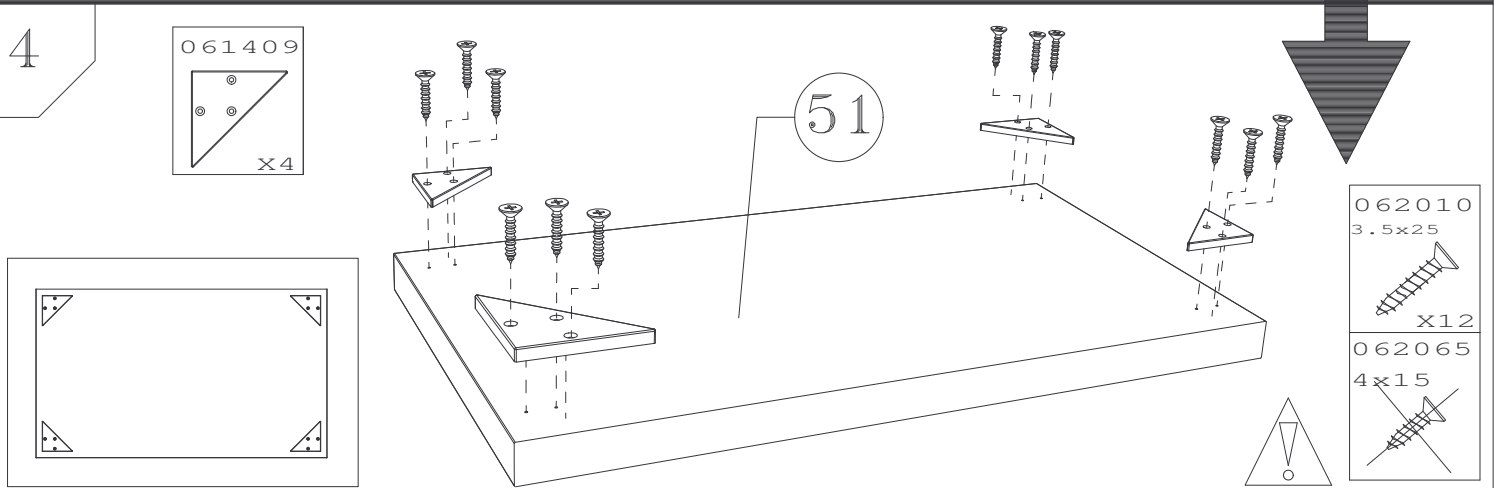
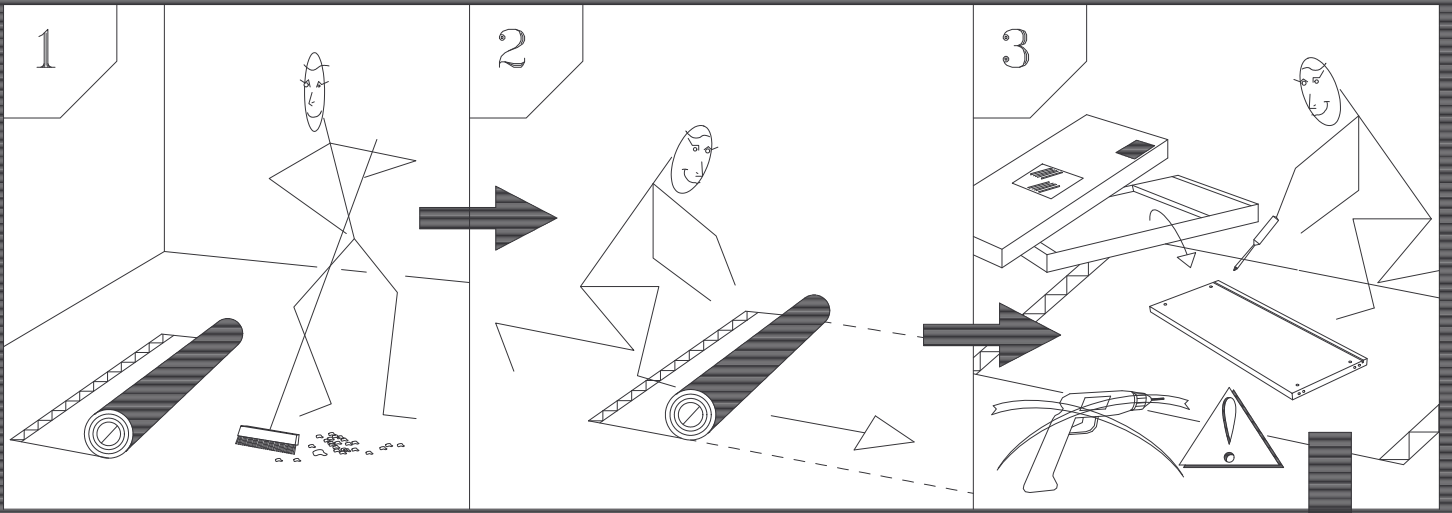

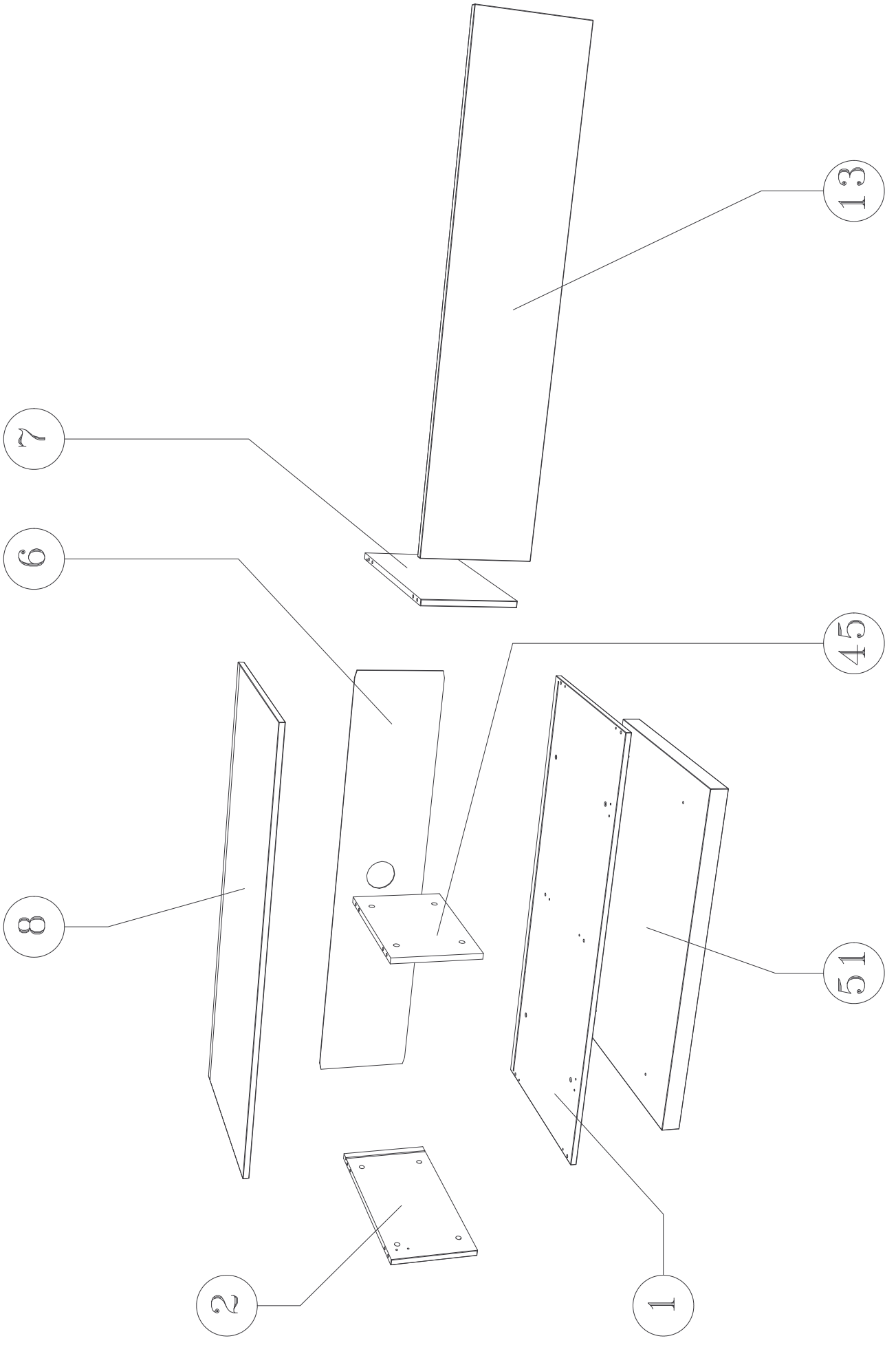

Quincaillerie - Fitment - Beschlagbeutel - herrajes  
 Verbindung - Quinquilharia - Ferramenta - ОУФНІТРА - 配件

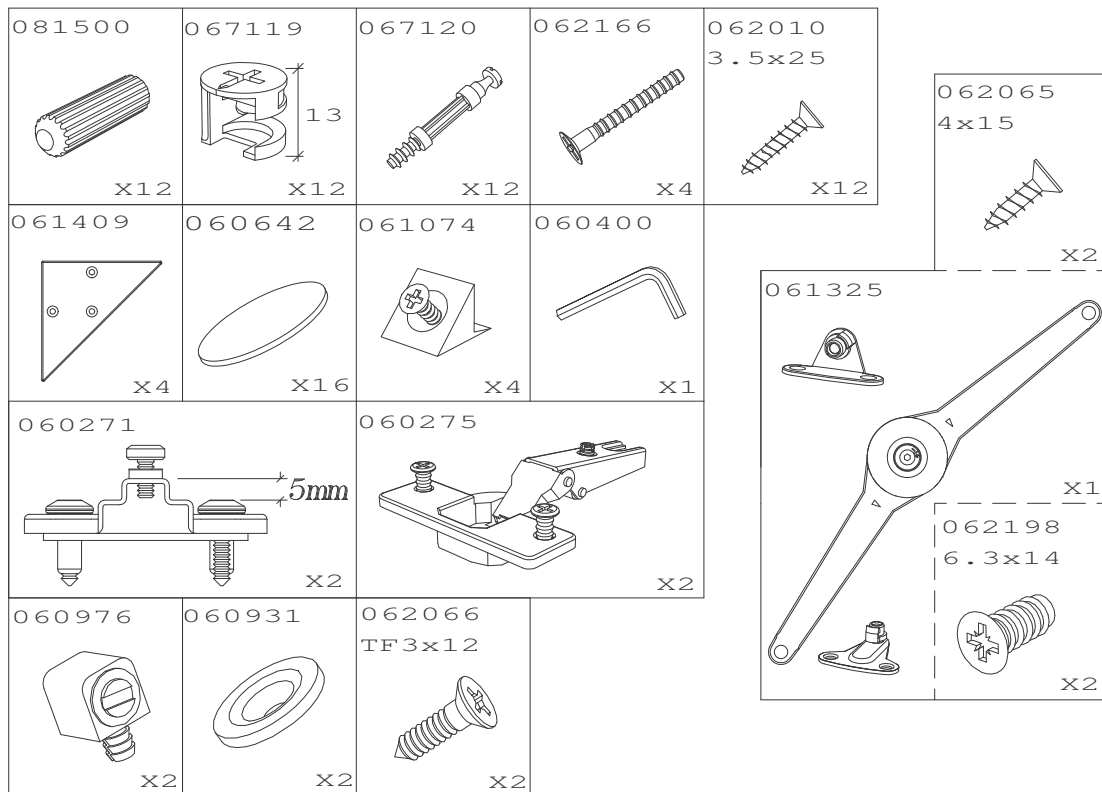

(F)	NUMERO	NOM DE LA PIECE	QUANTITE	COLIS
(GB)	NUMBER	NAME OF THE PIECE	QUANTITY	PARCEL
(D)	NUMMER	NAME DER TEILE	MENGE	PAKET
(E)	NUMERO	NOMBRE DE LA PIEZA	CANTIDAD	PAQUETE
(NL)	NUMMER	NAAM VAN HET ARTIKEL	AANTAL	COLLI
(P)	NUMERO	NOME DA PECA	QUANTIDADE	PACOTE
(I)	NUMERO	NOME DEL PEZZO	QUANTITA	COLI
(RU)	НОМЕР	НАЗВАНИЕ ДЕТАЛИ	КОЛИЧЕСТВО	УПАКОВОЧНОЕ МЕСТО
(CN)	数字	部件名称	数量	包裹
	1	Dessous	1	1
	2	Coté gauche	1	1
	6	Derrière	1	1
	7	Coté droit	1	1
	8	Dessus	1	1
	13	Abattant	1	1
	45	separation d'abattant	1	1
	51	Dessous socle	1	1
		QUINCAILLERIE-FITMENT BESCHLAGBEUTEL-HERRAJES VERBINDING-QUINQUILHARIA FERRAMENTA-ОУФНІТРА- 配件	1	1



7

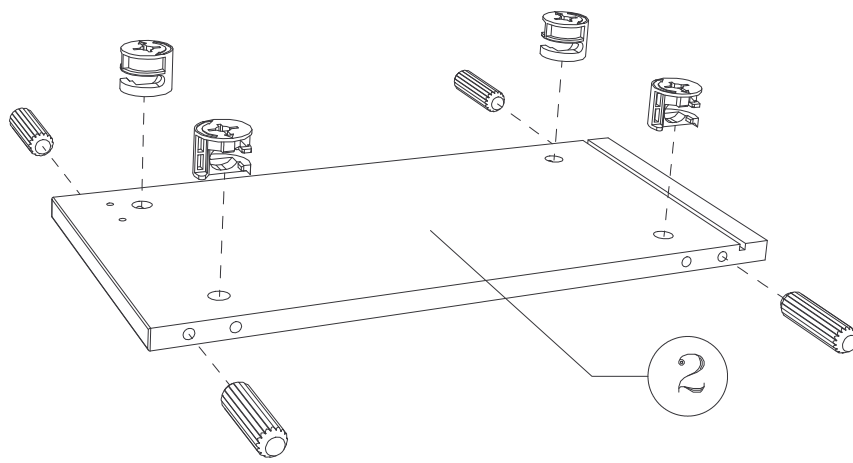

081500	067119
X4	X4

8

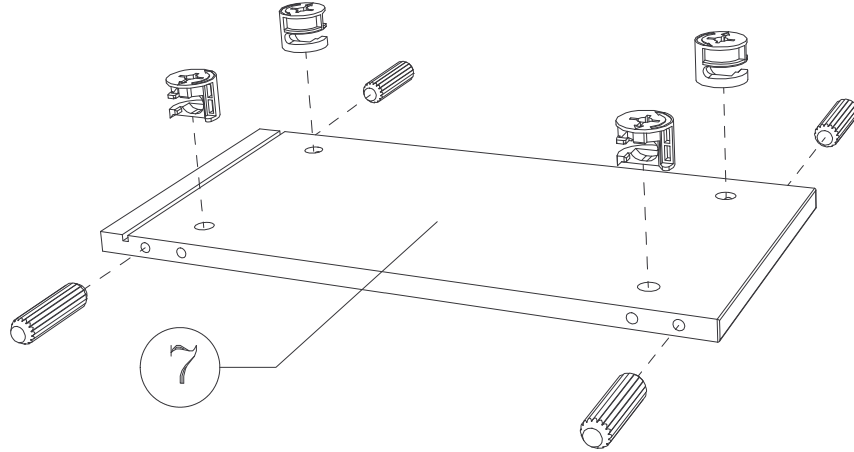

081500	067119
X4	X4

9

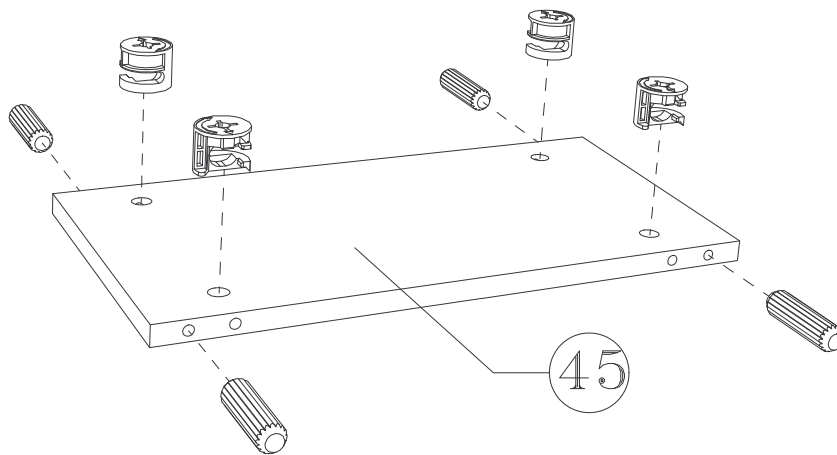

081500	067119
X4	X4

10

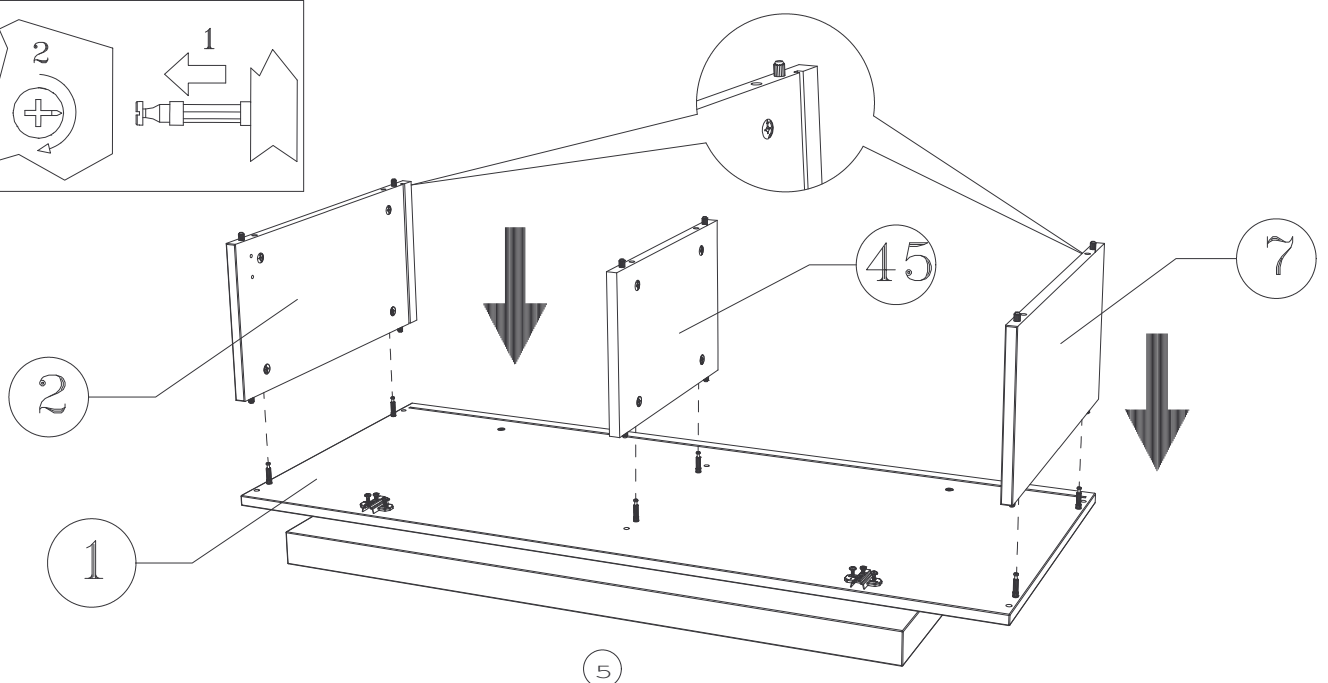
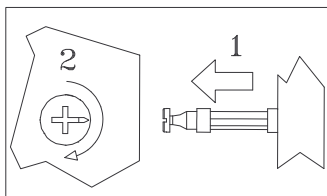

11

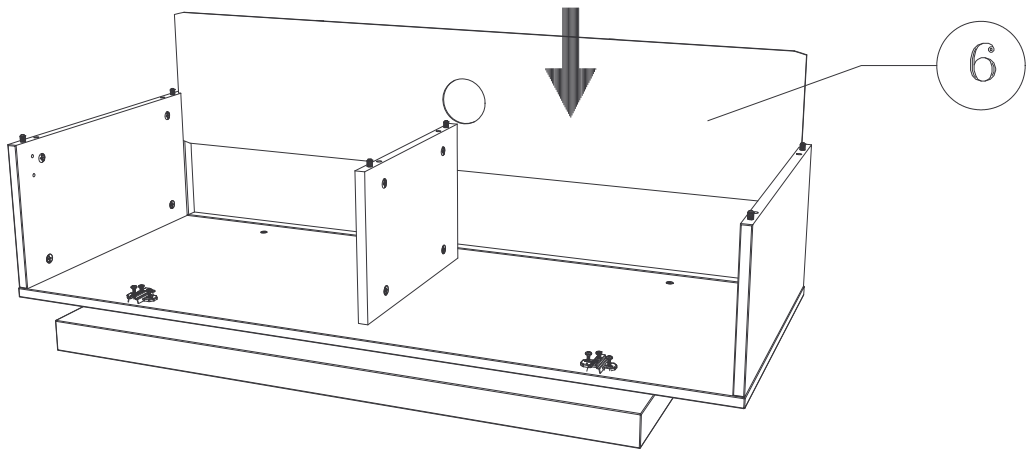

12

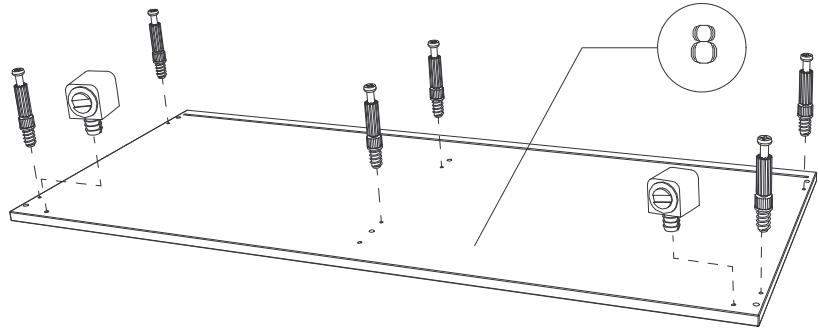
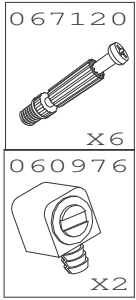

13

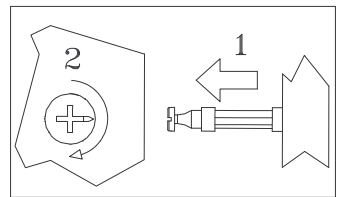
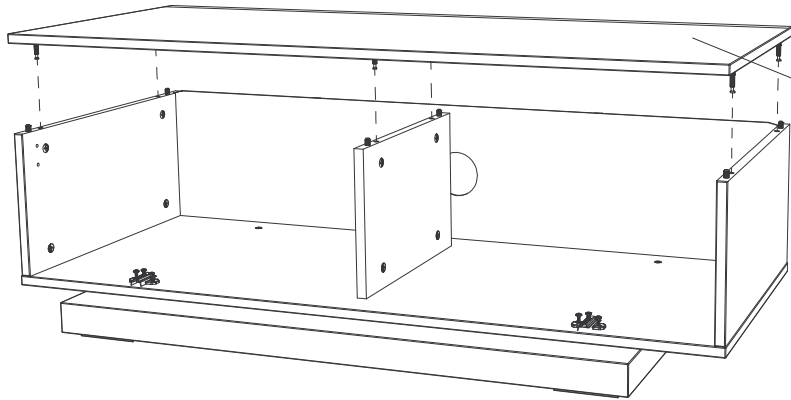

14

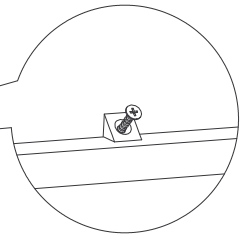
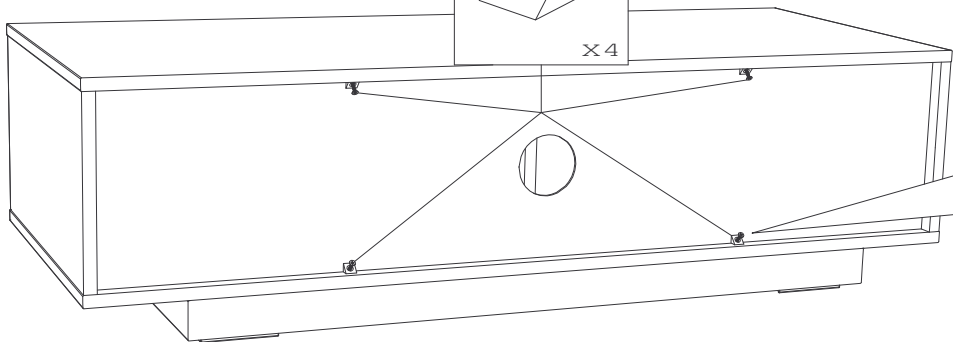
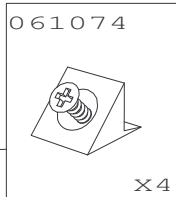

15

13

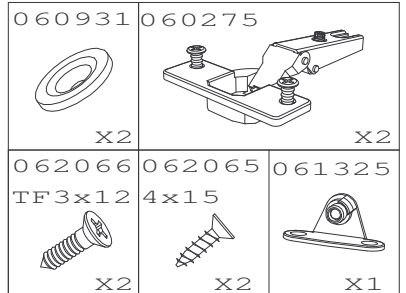
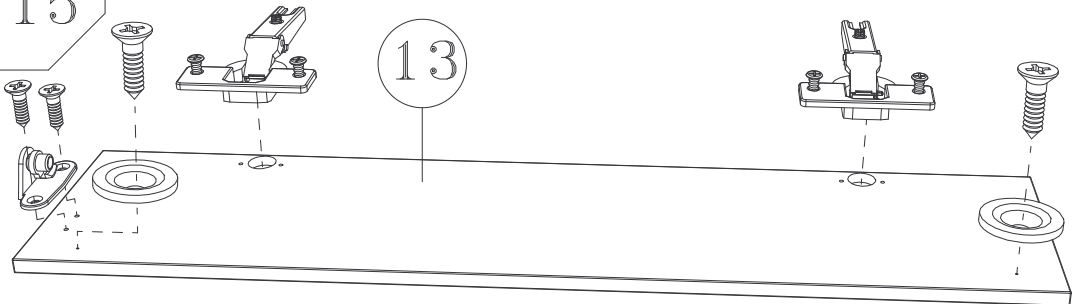

6

16

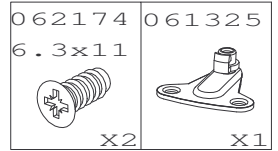
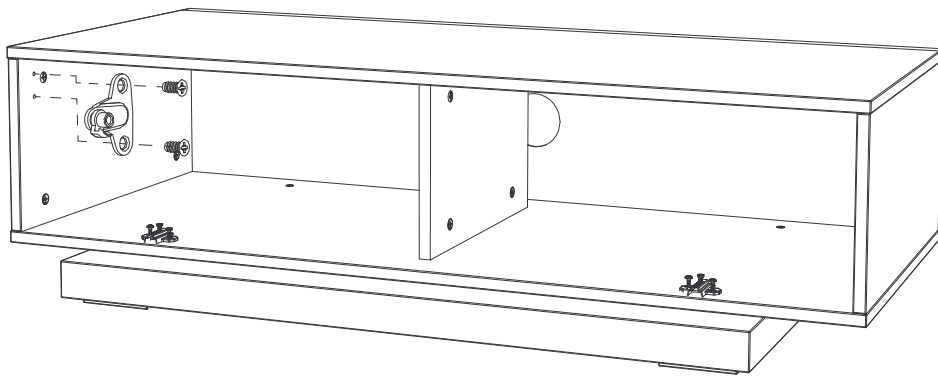

17

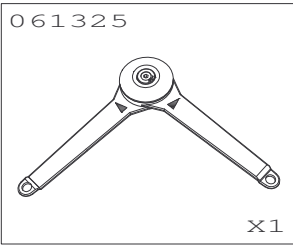
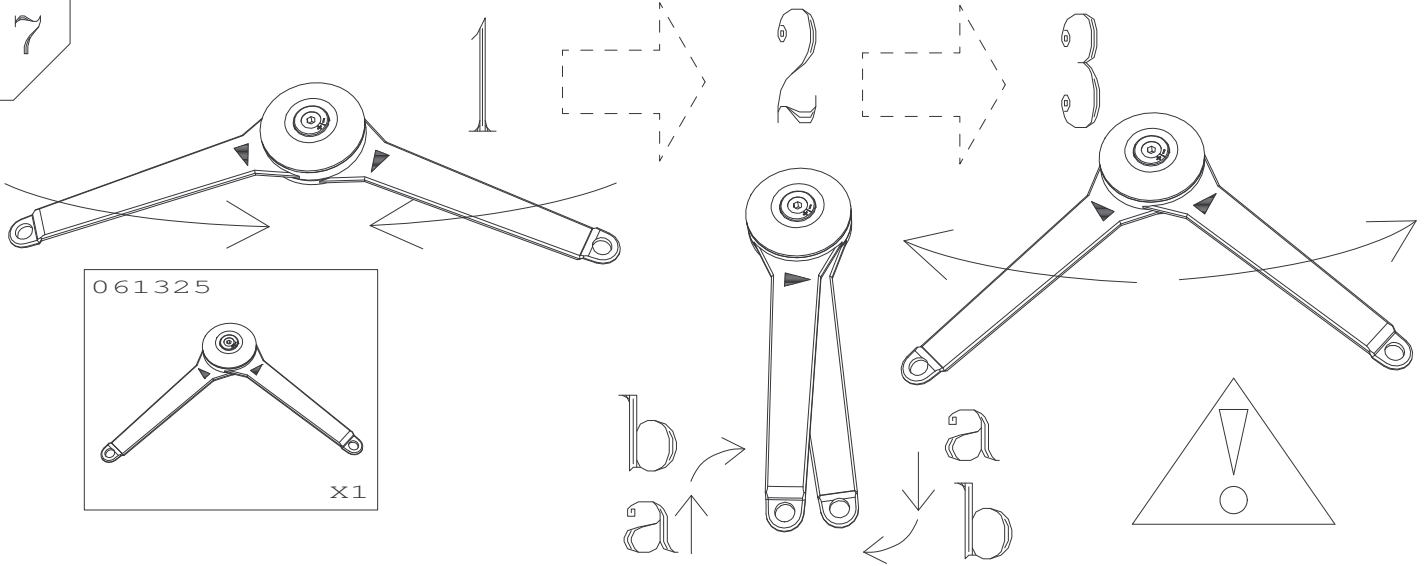

18

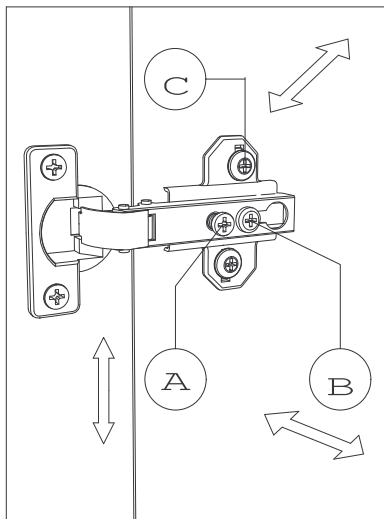
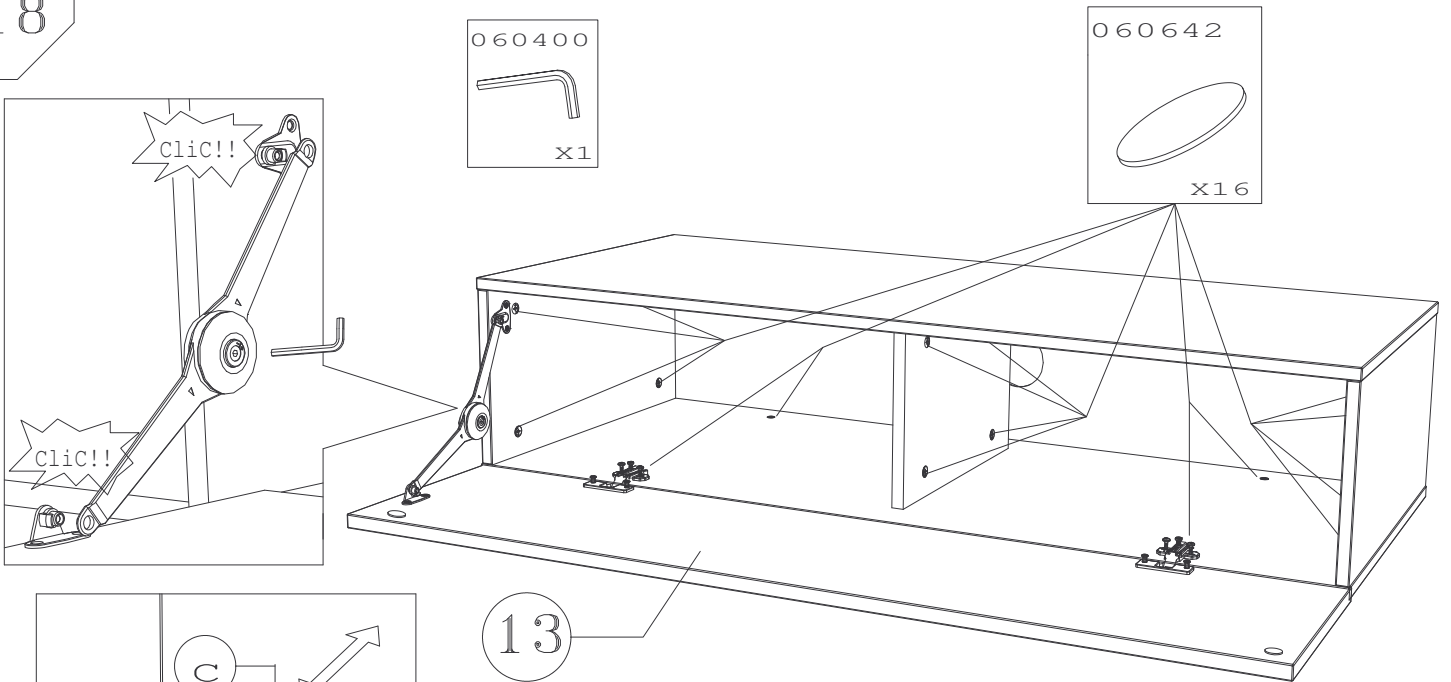

13

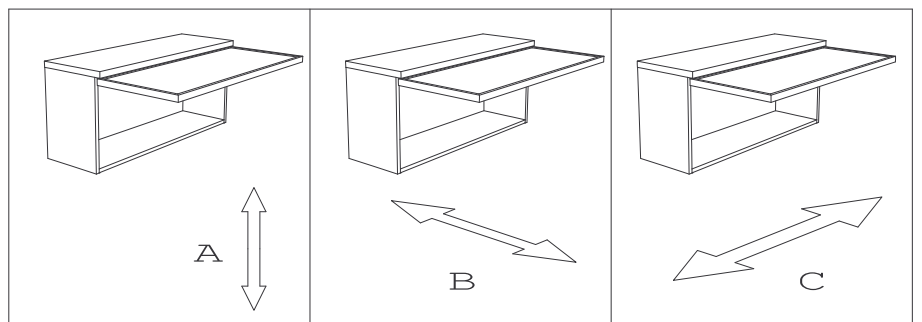

**F**

L'ÉQUIPEMENT DES PIÈCES ET LE MONTAGE DU MEUBLE DOIVENT ÊTRE RÉALISÉS SUR UN PLAN DE TRAVAIL PROPRE ET PROTÉGÉ.

LORS DE L' UTILISATION, PROTÉGER LE VERNIS DES RAYURES ET DES TACHES.

DÉPOUSSIÉRER LES MEUBLES AVEC UN CHIFFON PROPRE, DOUX ET SEC.

**GB**

Parts fitting and assembling should be realized on a clean and well protected work top.

For use, please protect the lacquer from scratches and spottings.

Dust each furniture items with a soft, clean, dry cloth. Do not use abrasive cleaners.

**D**

Das Montage der Teile und der Möbel sollen auf ein sauber und geschützte Arbeitsplatz gemacht sein.

Schützen Sie das Lack vor Kratzer und Flecke wenn benützung.

Stauben Sie die Möbel mit ein trockenes, sauber, weiches, Staubtuch ab.

**E**

La instalacion de las piezas y el montaje del mueble han de realizarse sobre un plano limpio y protegido.

Al usar, hay que proteger el barniz de rayas y manchas.

No se olvida desempolvar los muebles con un trapo limpio, suave y seco.

**P**

O equipamento das peças e a montagem devem ser feitos num plano de trabalho limpo e protegido.

Durante a utilização, proteger o verniz das manhueros e das manchas.

Limpar o po com pano limpo e macio e seco.

**I**

La disposizione delle parti e il montaggio del mobile devono essere organizzate su un piano di lavoro adatto e sicuro.

Durante l'uso, proteggere le vernici dai graffi e dalle macchie.

Spolverare i mobili con un panno morbido e asciutto

**RU**

Сборка частей и монтаж мебели должны производиться на освобожденном и подготовленном месте.

В течение эксплуатации стола беречь лак от царапин и пятен.

Стирать пыль с мебели чистой, мягкой и сухой тканью.

**CN**

零部件装备和家具安装必须在洁净、有保护的操作台上进行

使用桌面时注意表漆，避免产生刮痕和污点

用干净、柔软的干抹布除去家具表面的灰尘

**GARANTIE**

SI VOUS CONSTATEZ UNE ÉVENTUELLE ANOMALIE, PRECISEZ LA NATURE DU DÉFAUT SUR CETTE FICHE ET RETOURNEZ-LA AU MAGASIN QUI VOUS A VENDU LE MEUBLE. CE DOCUMENT NOUS SERA IMMÉDIATEMENT TRANSMIS.

**GARANTY**

IN THE UNLIKELY EVENT OF THERE BEING A MANUFACTURING OR MATERIAL DEFECT, PLEASE CONTACT THE RETAILER FROM WHOM YOU PURCHASED OUR FURNITURE WITHOUT DELAY. STEPS WILL THEN BE TAKEN TO EFFECT EARLY REMEDICAL ACTION.

**GARANTIE**

SOLLTEN SIE EVENTUELL EINEN MANGEL FESTSTELLEN SO BITTEN WIR SIE, UNS DIESEN NACHSTEHEND ZU BESCHREIBEN UND DIESES BLATT IHREM LIEFERANTEN ZUZUSENDEN.

**GARANTIA**

SI USTED OBSERVA ALGUNA EVANTUAL ANOMALIA, EXPLIQUE EL INDOLE DEL DEFECTO Y DEVUELVA LA FICHA A LA TIENDA DONDE HA COMPRADO EL MUEBLE QUE NOS LA HARA SEGUIR.

**GARANTIA**

SE DETECTAREM UMA EVENTUAL ANOMALIA, DEFINA A NATUREZA DO DEFEITO NESTA FICHA E DEVOLVAM A LOJA QUE LHE VENDEU OS MOVEIS, ESTE DOCUMENTO NOS SERA IMEDIATAMENTE TRANSMITIDO.

**GARANZIA**

SE RICONTRATE UN EVANTUALE ANOMALIA, INDICATE LA NATURA DEL DIFETTO SU QUESTA SHEDA TECNICA E REPORTATELA COMPILATA AL PUNTO VENDITA CHE VI HA VENDUTO QUESTO MOBILE. QUESTO DOCUMENTO CI SARA TRANSMESSO IMMEDIATAMENTE.

**ГАРАНТИЯ :**

ЕСЛИ ВЫ ВДРУГ ОБНАРУЖИЛИ ДЕФЕКТЫ МАТЕРИАЛА ИЛИ ПРОИЗВОДСТВА, ТОЧНО ОПИШИТЕ ДЕФЕКТ НА ЭТОМ ЛИСТЕ И ОБРАТИТЕСЬ В МАГАЗИН, В КОТОРОМ ВЫ КУПИЛИ МЕБЕЛЬ. ЭТОТ ДОКУМЕНТ БУДЕТ НЕМЕДЛЕННО НАМ ПЕРЕДАН И НАМИ РАССМОТРЕН

**RU****CN****保证**

如果您发现产品存在制造或是材质问题，请尽快联系您的购买商店，以便我们及时向您反馈。

NOM - NAME : \_\_\_\_\_

N° REF : \_\_\_\_\_

ADRESSE - ADRESS : \_\_\_\_\_

DEFAULT - DEFAULT : \_\_\_\_\_