



NOTICE DE MONTAGE

MONTAGE HANDLEIDING

ASSEMBLY INSTRUCTION

FOLHA DE MONTAGEM

AUFBAUANLEITUNG

ИНСТРУКЦИЯ ПО СБОРКЕ

INSTRUCCIONES DE MONTAJE

安装手册

 *ligne intemporelle*

# CALIS

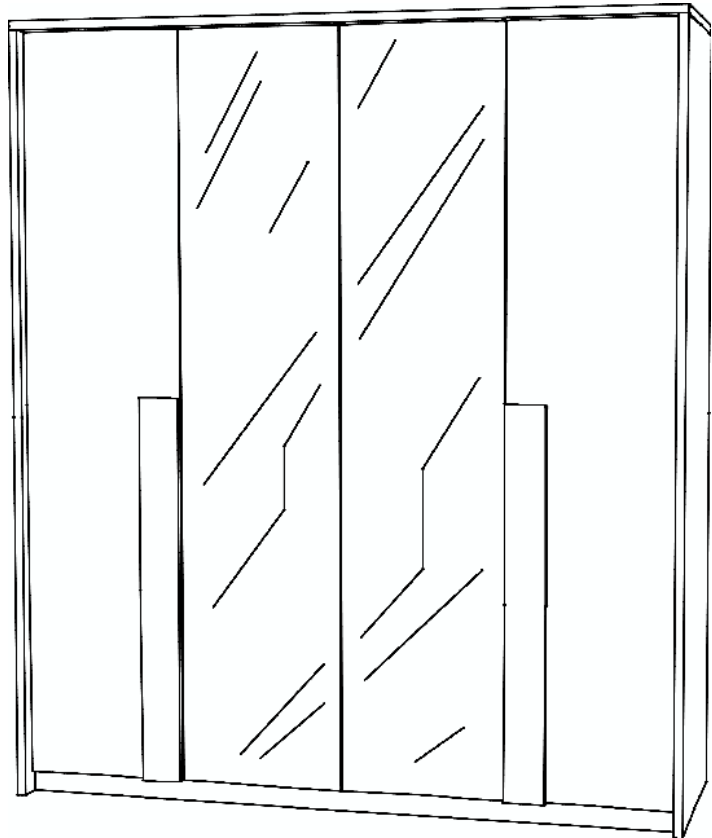

CALIS 41 ARMOIRE 4PO 2GL Réf. : 09CB5420

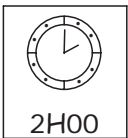
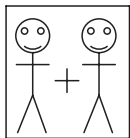

OUTILLAGES TOOLS HANDWERKZEUGE HERRAMIENTA GEREEDSCHAP  
FERRAMEN ИНСТРУМЕНТЫ ДЛЯ СБОРКИ 工具

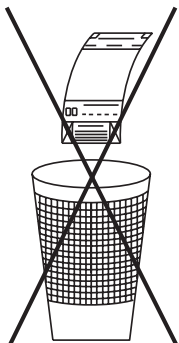
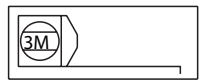
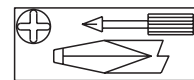
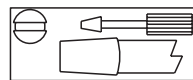
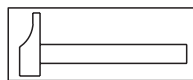
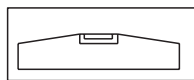

- F**
- GB**
- D**
- E**
- NL**
- P**
- RU**
- CN**

POUR L'APRES-VENTE, RETOURNEZ AU MAGASIN AVEC CETTE NOTICE

FOR THE AFTER SALES, GO BACK TO THE SHOP WITH THIS ASSEMBLY INSTRUCTION

WENDEN SIE SICH BITTE AN IHREN HANDLER UND GEBEN SIE IHM DIE KENNUMMER DES MOBELS UND DIE TEILNUMMER

EN CASO DE SERVICIO POST-VENTA DEBEN DE VOLVER A LA TIENDA CON LAS INSTRUCCIONES DE MONTAJE

VOOR SERVICE NA VERKOOP, GA NAAR UW LEVERANCIER MET DEZE MONTAGE HANDLEIDING

PARA O POS VENDA, VOLTE A LOJA COM ESTA FOLHA

ДЛЯ ПОСЛЕПРОДАЖНОГО ОБСЛУЖИВАНИЯ ПРОСЬБА ОБРАТИТЬСЯ В МАГАЗИН , ПРЕДЪЯВИВ НАСТОЯЩУЮ ИНСТРУКЦИЮ ПО СБОРКЕ.

请求售后服务时，请带好该手册找到当地的商店



SOLVANT  
DILUANT  
LÖSUNGSMITTEL  
SLOVENTE  
OPLOSMIDDEL  
OF THINNER  
РАСТВОРИТЕЛЬ  
溶剂

21

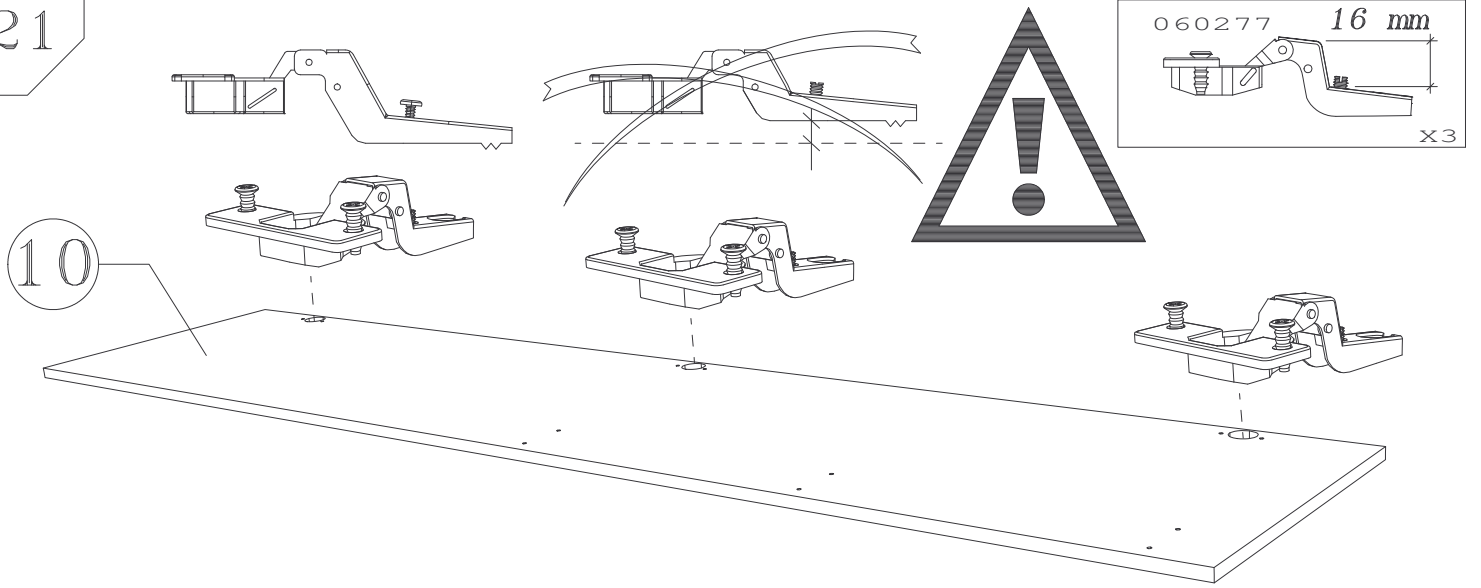



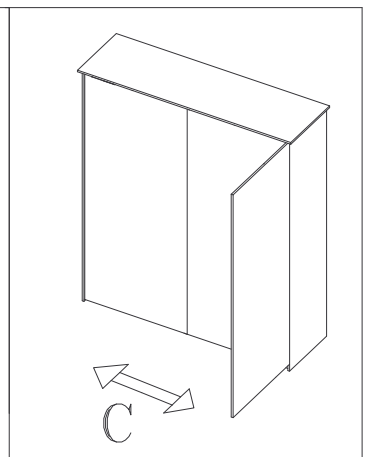
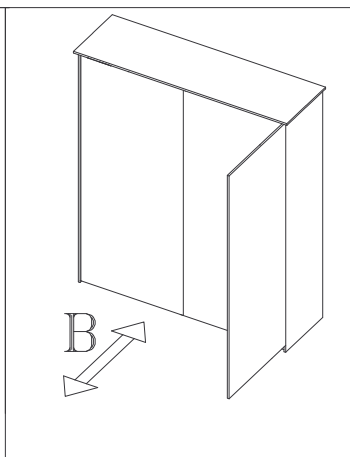
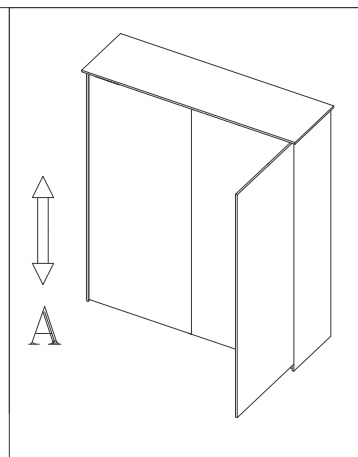
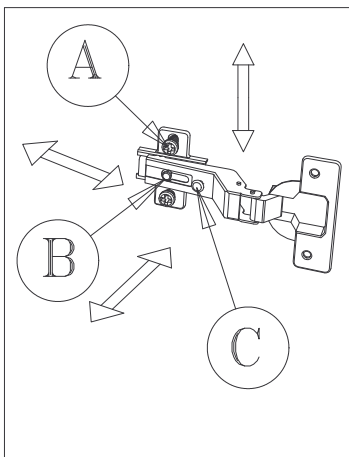
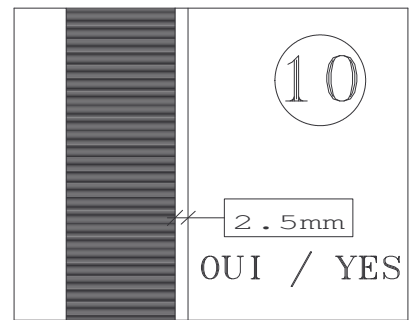
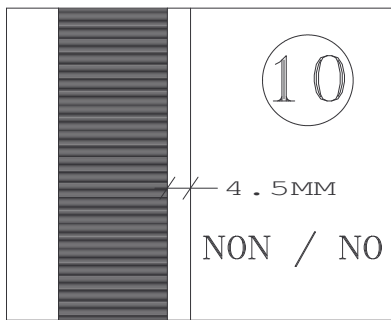
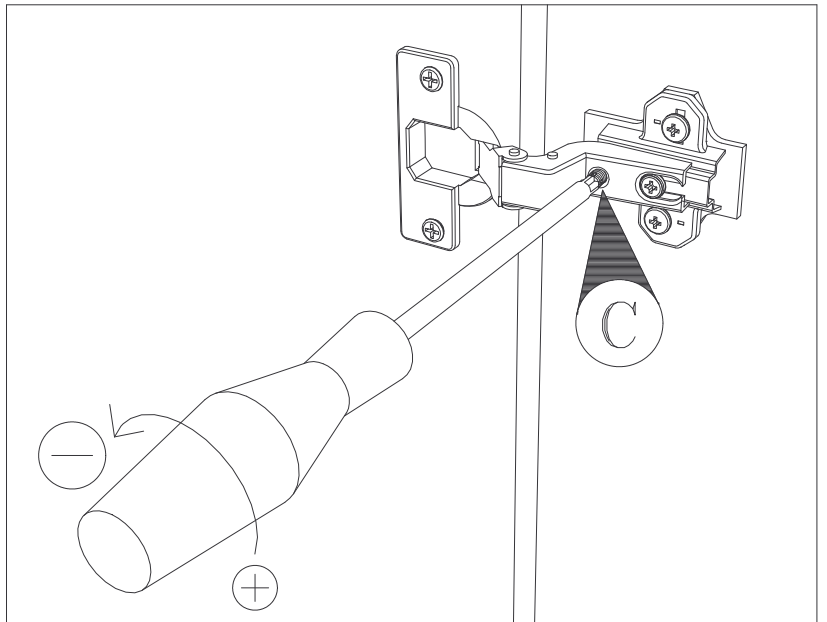

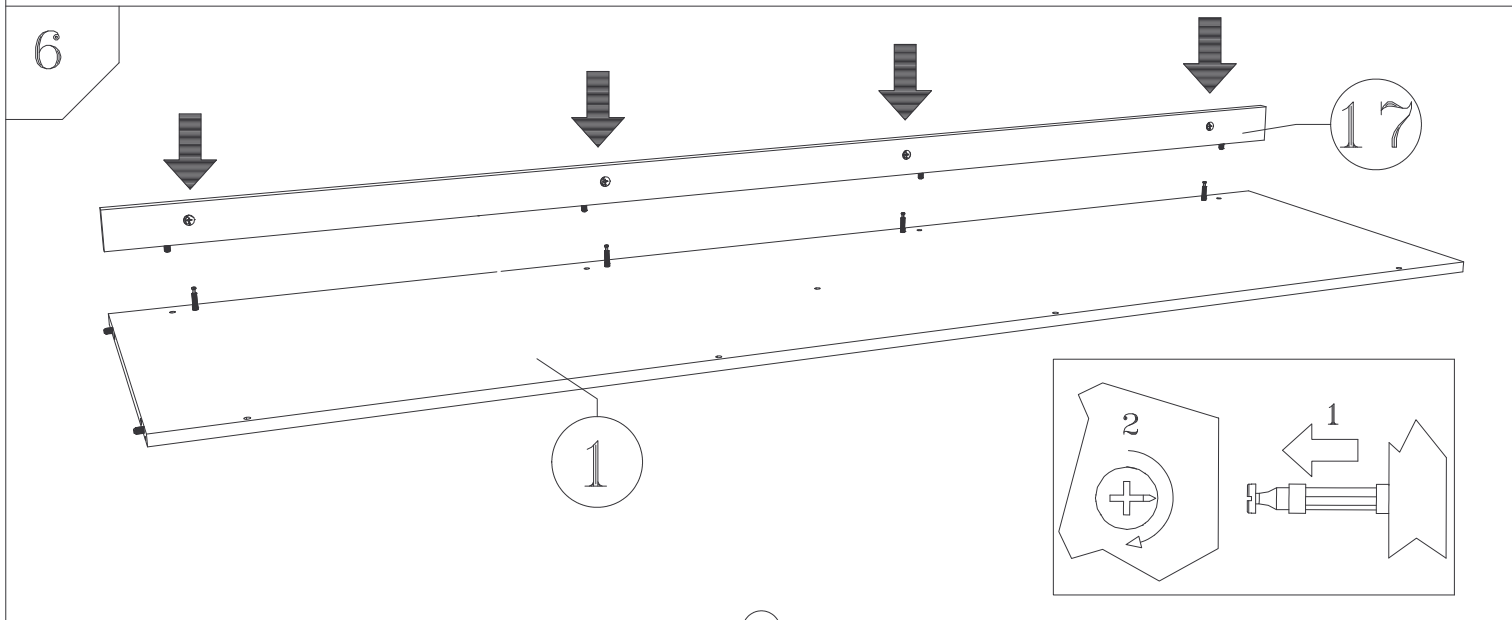
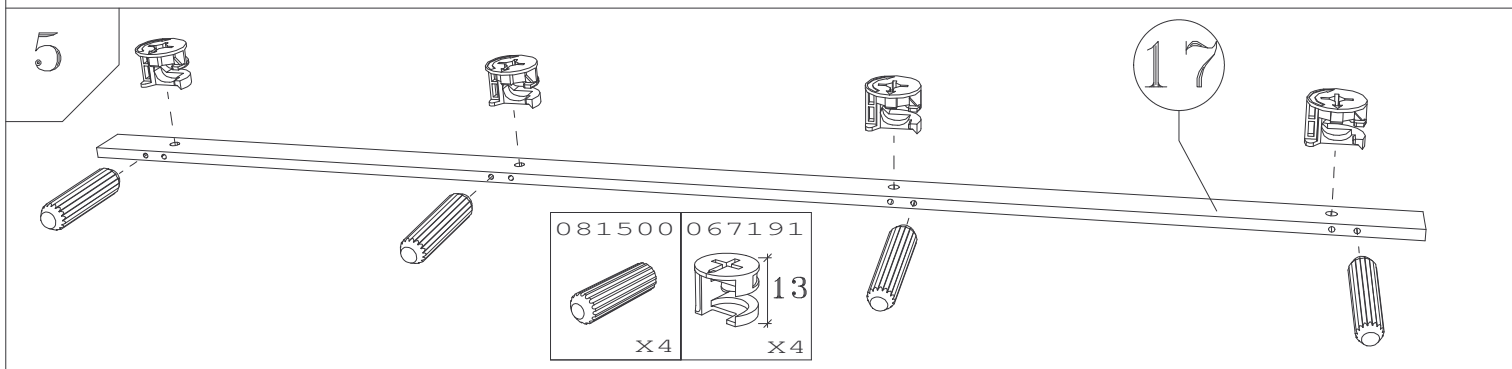
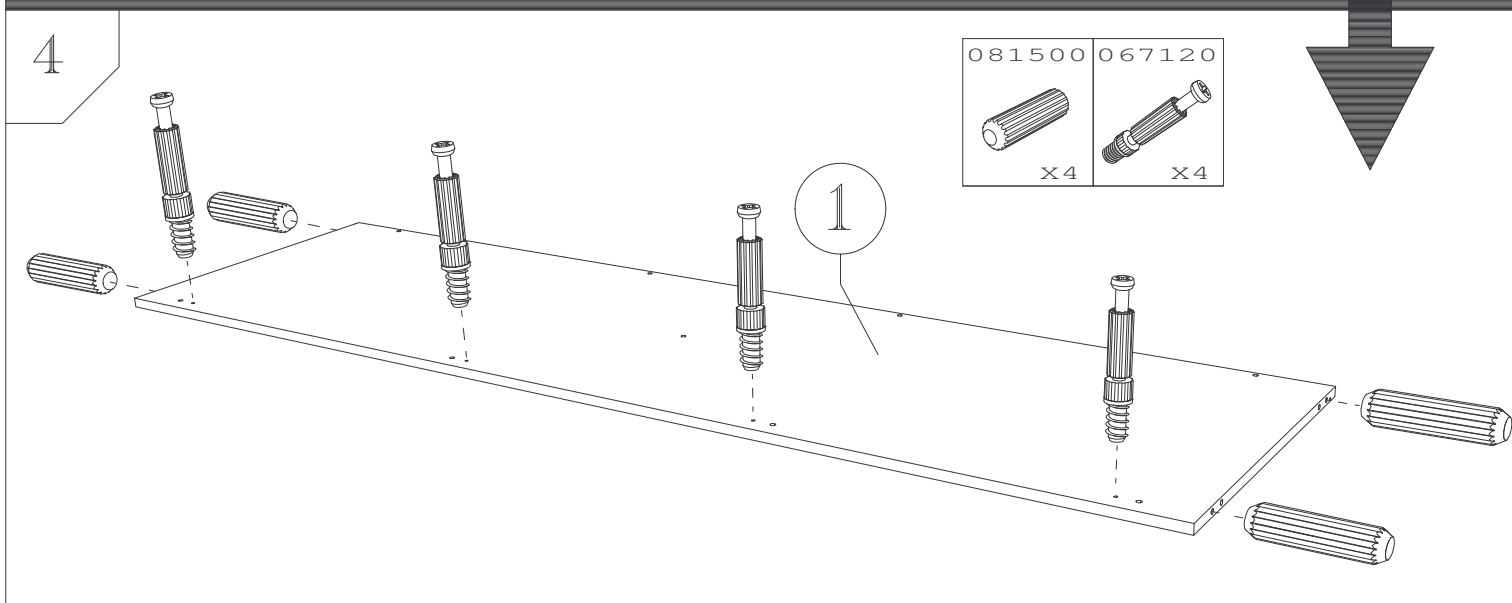
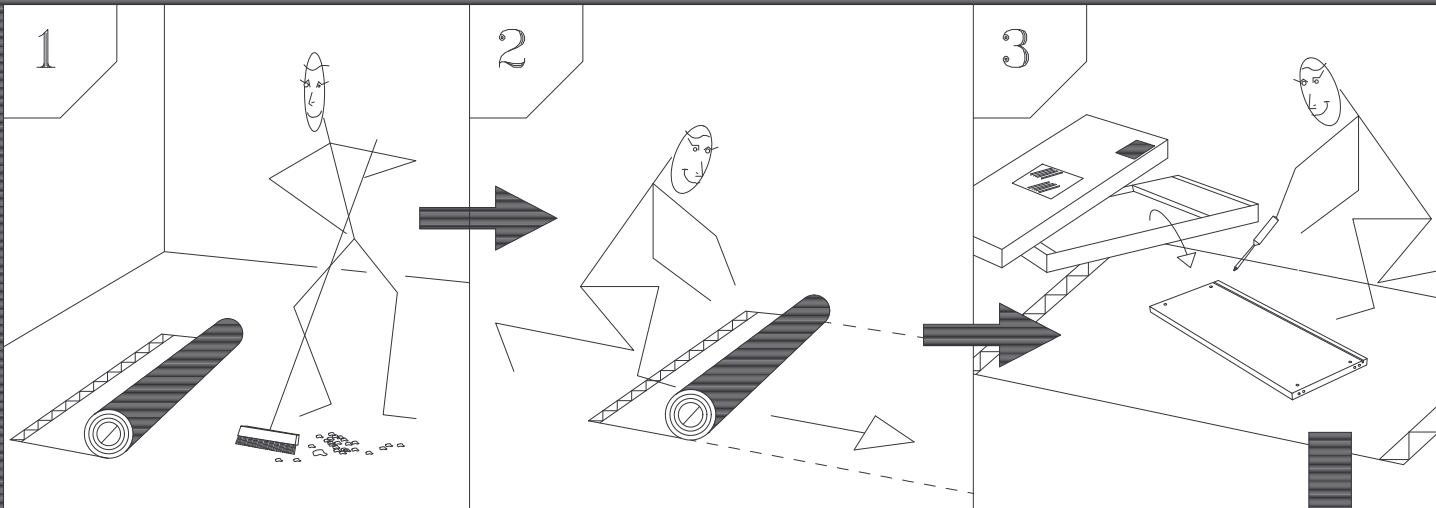

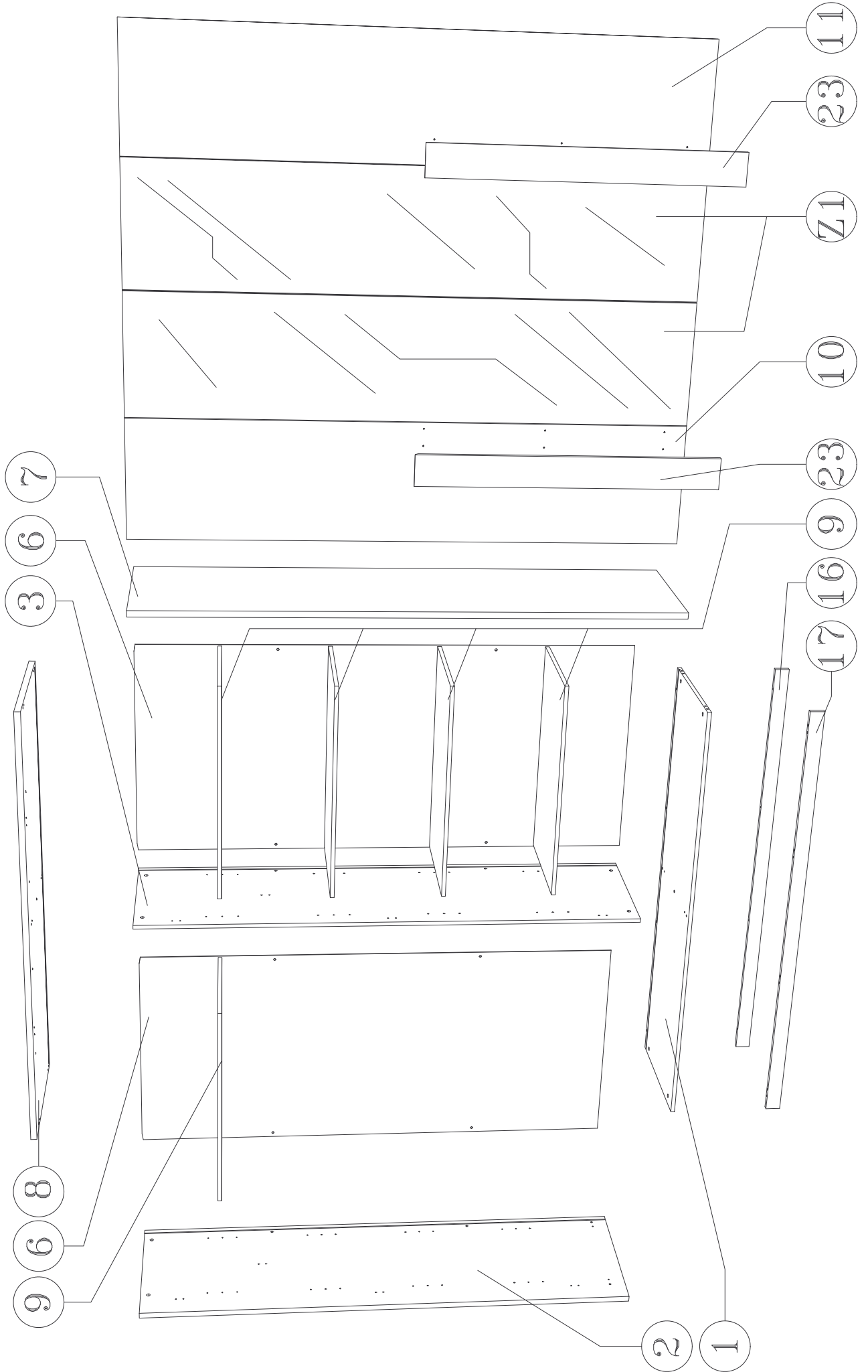

22

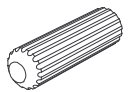
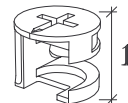
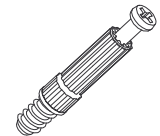
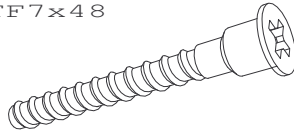
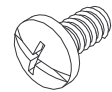

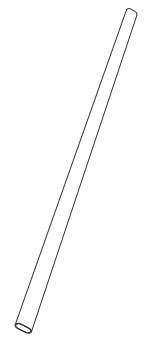
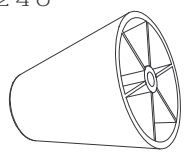

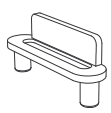

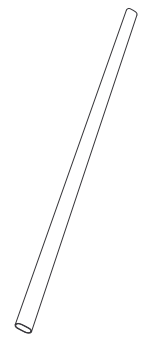
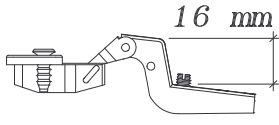
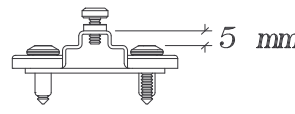
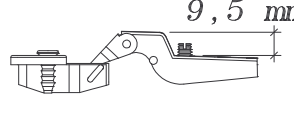
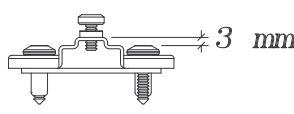
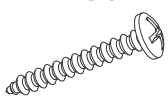
Quincaillerie - Fitment - Beschlagbeutel - herrajes  
 Verbindung - Quinquilharia - ОУФН/ТУПА - 配件

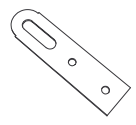
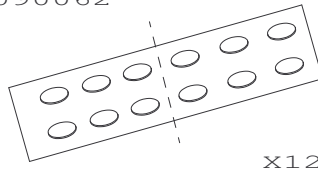
081500  X17	067191  13 X16	067120  X16	062166 TF7x48  X5	062116  X8	060145  X8	060134  X1
061240  X1	060144  X2	062004 3.5x15  X2	061006  X2	061122  X20	060664  X4	060134  X1
060277  16 mm X6	060271  5 mm X6	060276  9,5 mm X6	060270  3 mm X6			
062052 TR4x30  X12	061015  X12	062023 TF3x25  X4	061216  X2	090062  X12		

(F)	NUMERO	NOM DE LA PIECE	QUANTITE	COLIS
(GB)	NUMBER	NAME OF THE PIECE	QUANTITY	PARCEL
(D)	NUMMER	NAME DER TEILE	MENGE	PAKET
(E)	NUMERO	NOMBRE DE LA PIEZA	CANTIDAD	PAQUETE
(NL)	NUMMER	NAAM VAN HET ARTIKEL	AANTAL	COLLI
(P)	NUMERO	NOME DA PECA	QUANTIDADE	PACOTE
(RU)	НОМЕР	НАЗВАНИЕ ДЕТАЛИ	КОЛИЧЕСТВО	УПАКОВОЧНОЕ МЕСТО
(CN)	数字	部件名称	数量	包裹
	1	<i>Dessous</i>	1	1
	2	<i>Côté gauche</i>	1	2
	3	<i>Séparation</i>	1	1
	6	<i>Derrière</i>	2	4
	7	<i>Côté droit</i>	1	2
	8	<i>Dessus</i>	1	3
	9	<i>Tablette</i>	5	3
	10	<i>Porte gauche</i>	1	4
	11	<i>Porte droite</i>	1	4
	16	<i>Derrière de socle</i>	1	1
	17	<i>Face de socle</i>	1	1
	23	<i>Prise de main</i>	2	5
	Z1	<i>Porte centrale</i>	2	5
		QUINCAILLERIE-FITMENT BESCHLAGBEUTEL-HERRAJES VERBINDUNG-QUINQUILHARIA ОУФН/ТУПА- 配件	3	3



7

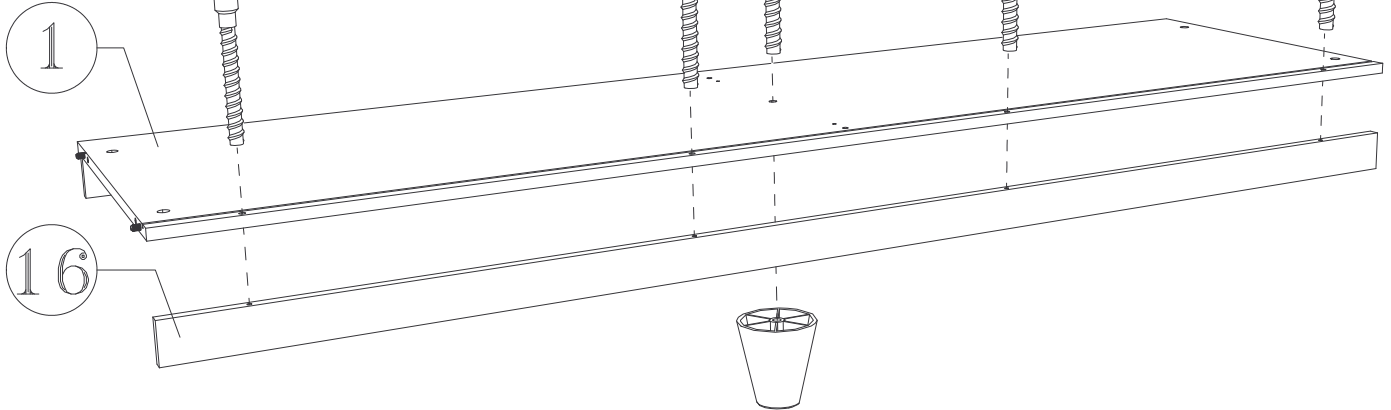
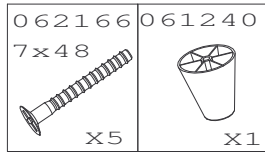

8

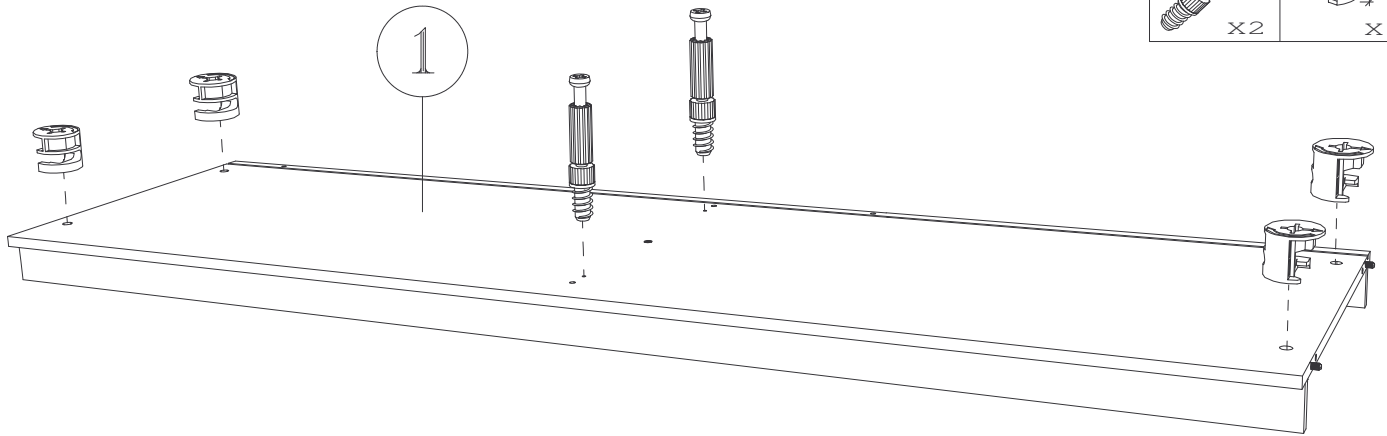
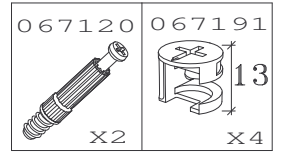



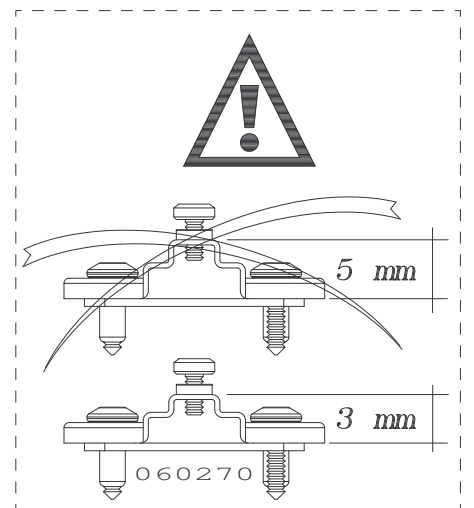
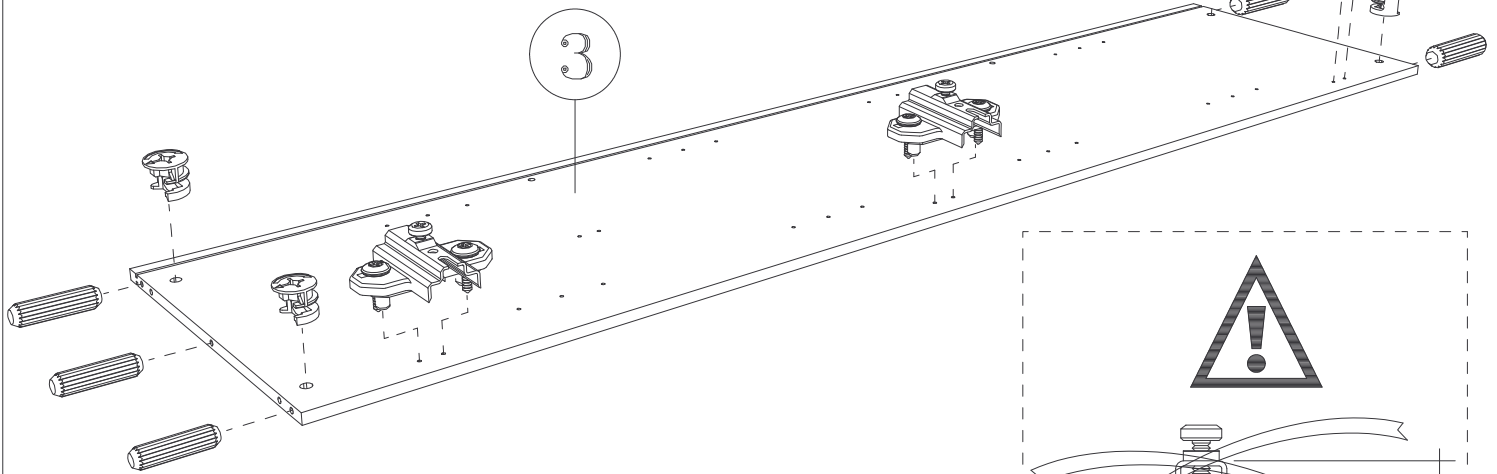
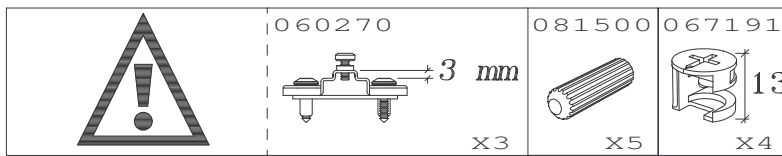

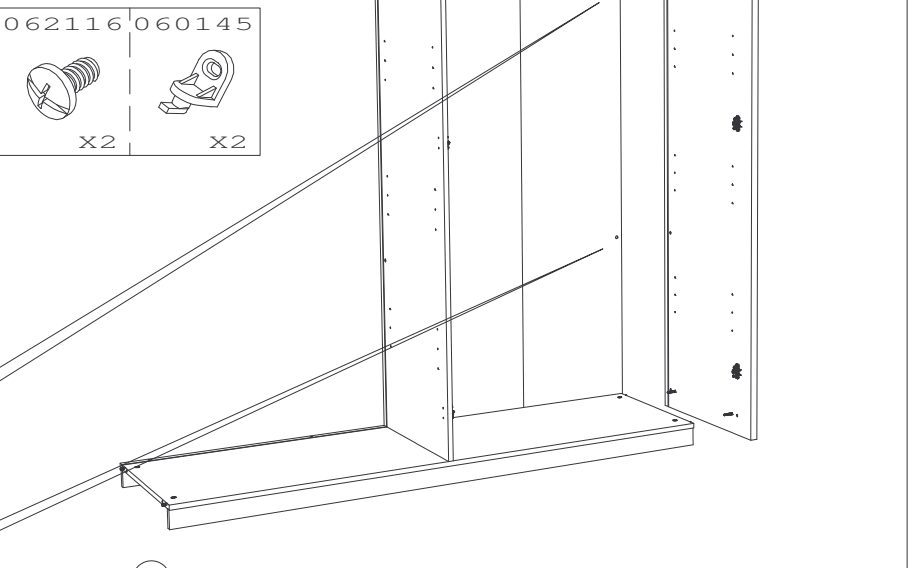
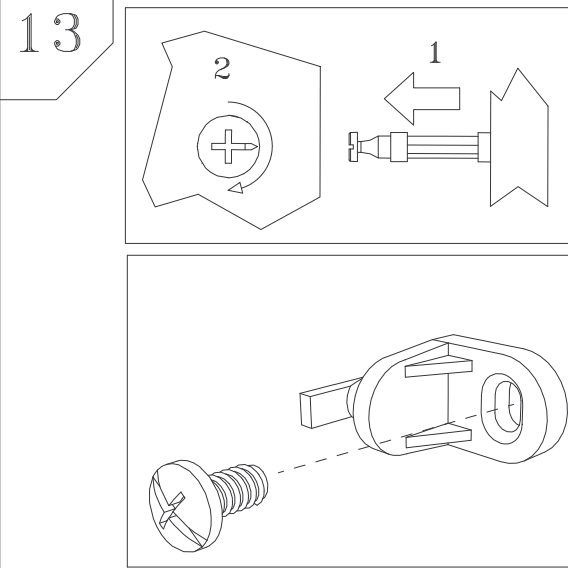
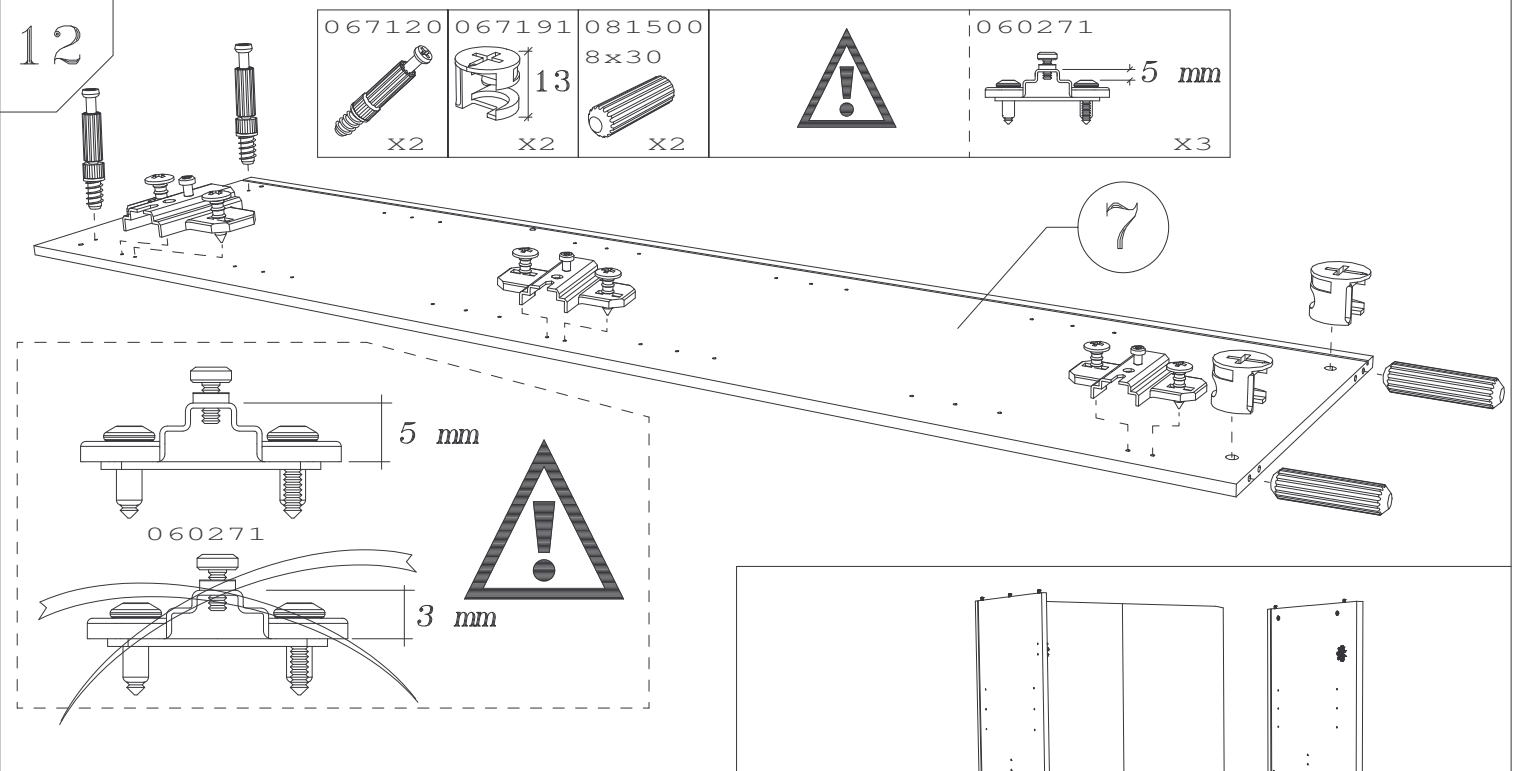
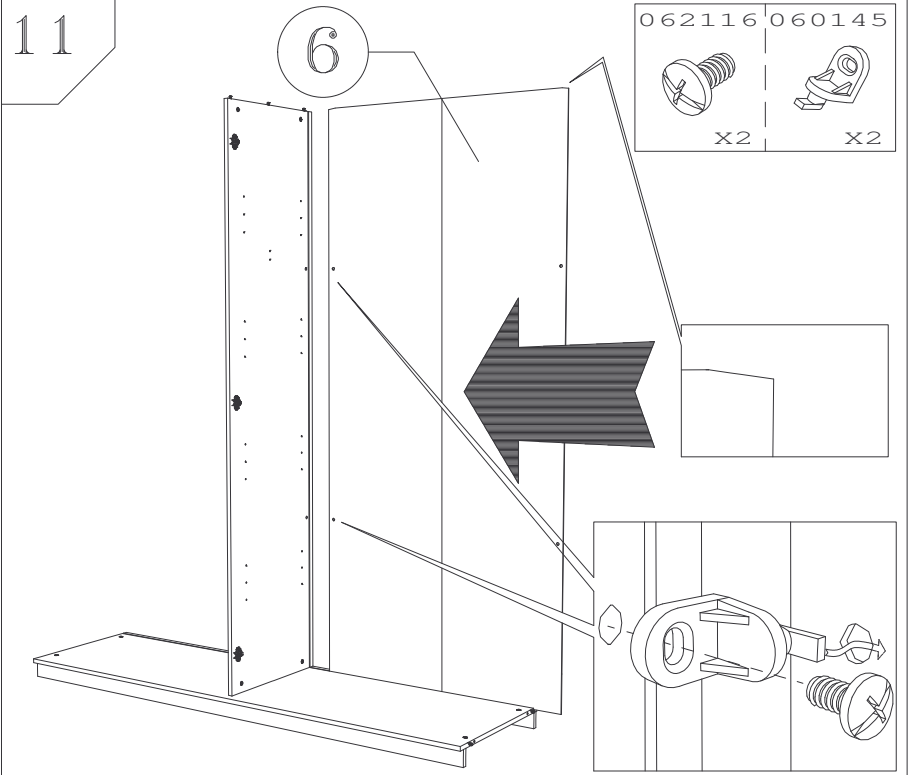
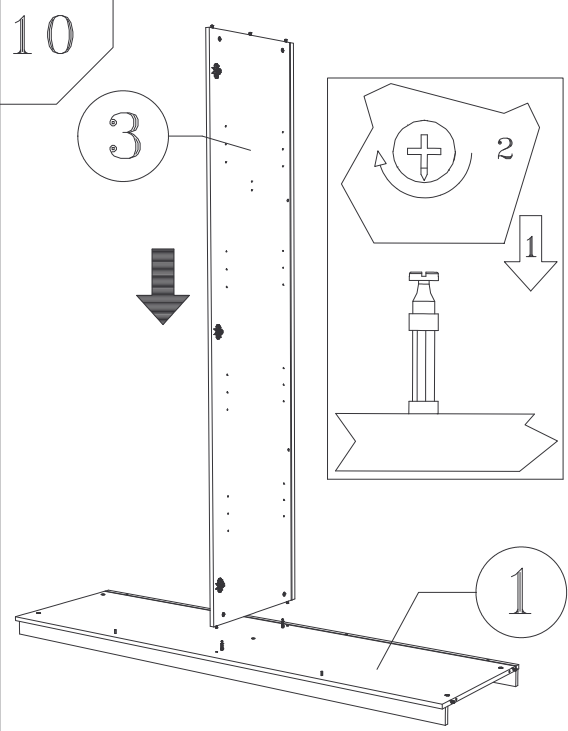
9



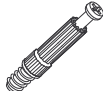
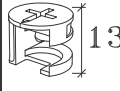

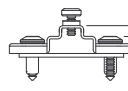

14

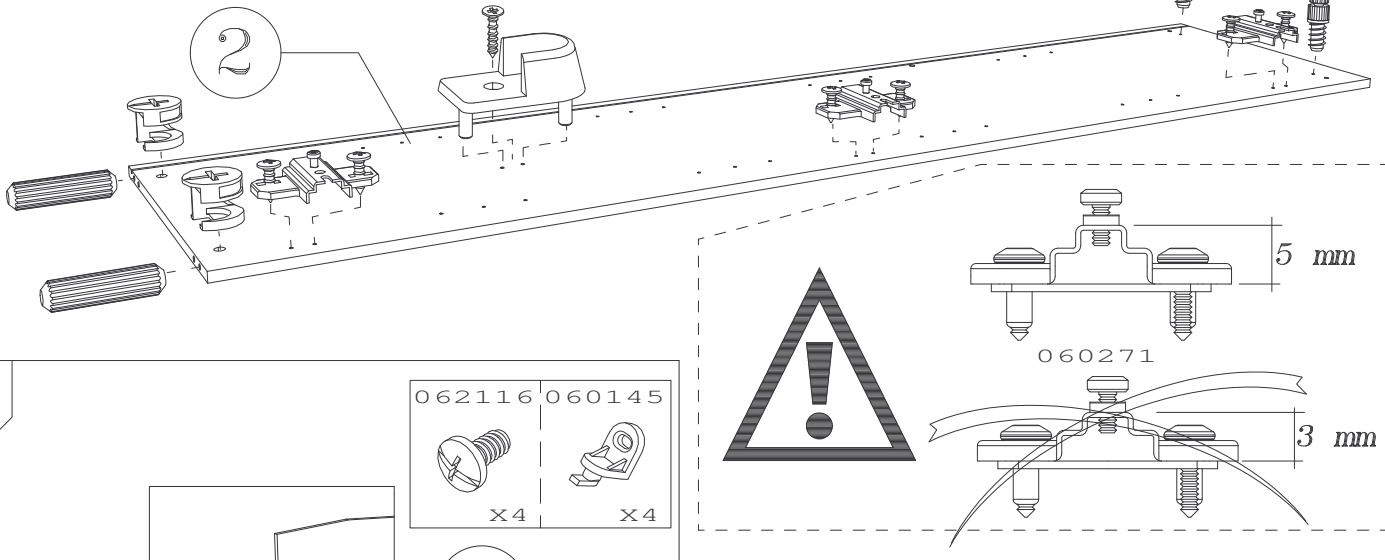
081500 8x30  X2	067120  X2	067191  13 X2	060144  X1	062004 3.5x15  X1		060271  5 mm X3
---	---	--	---	---	--	---



15

062116  X4	060145  X4
---	---

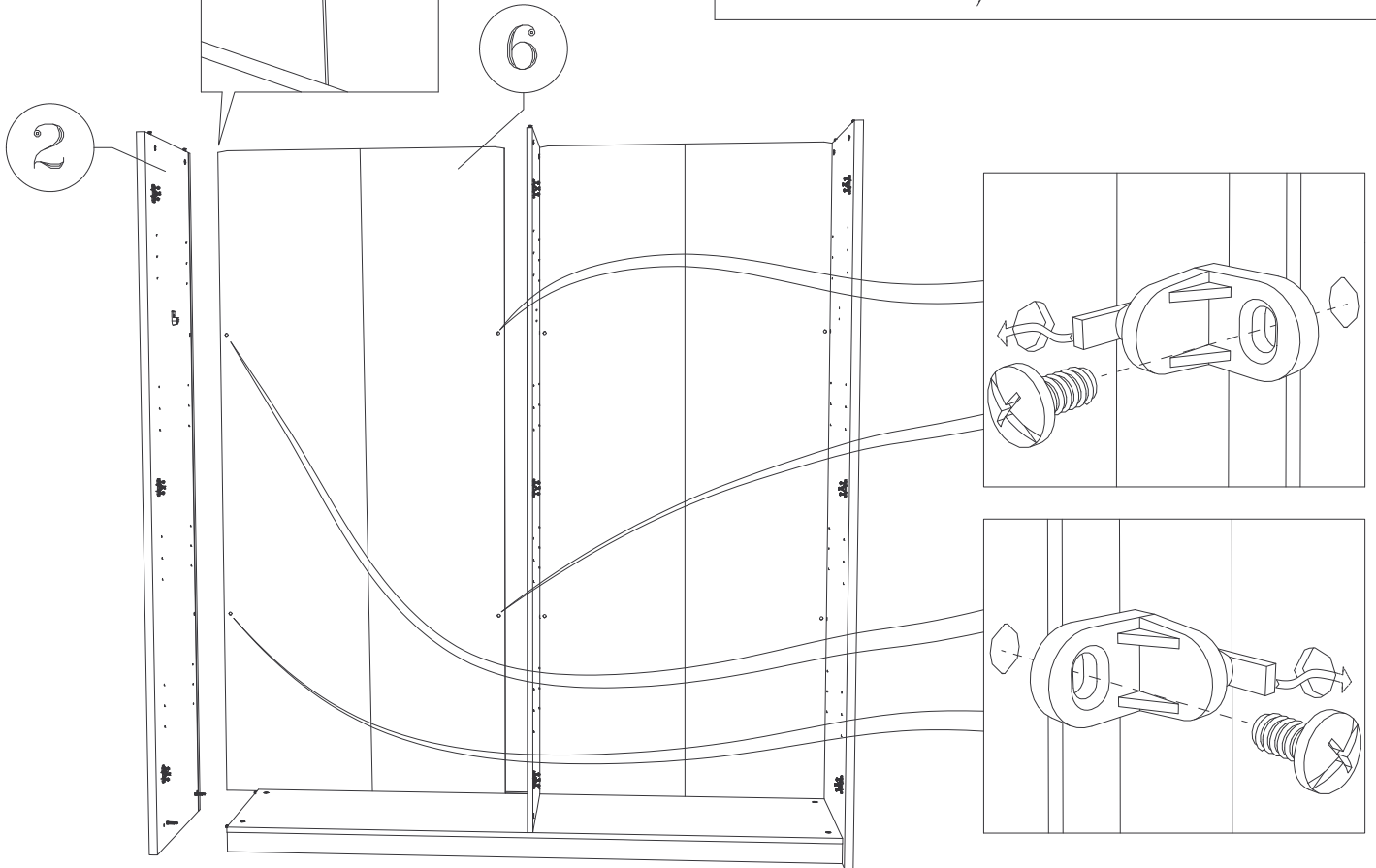
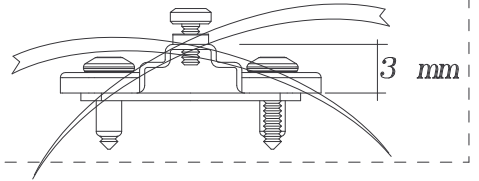
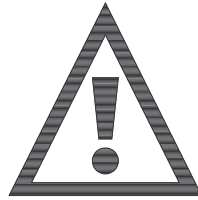

16

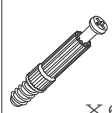
061006  X2	067120  X6
---	---

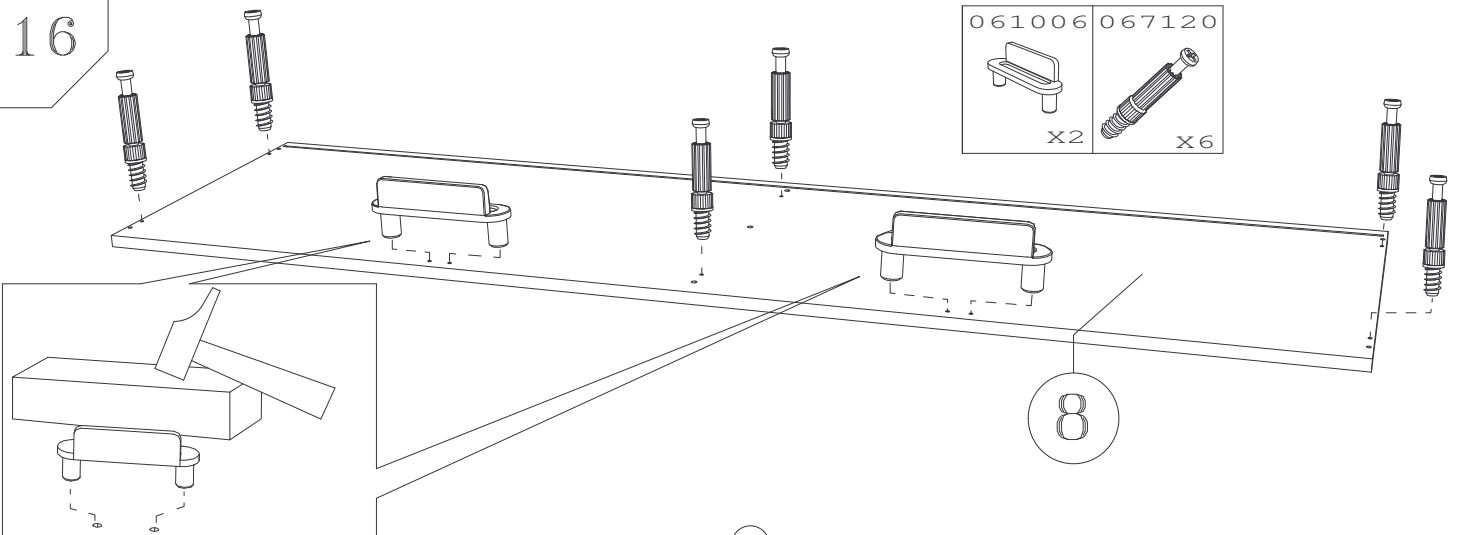

17

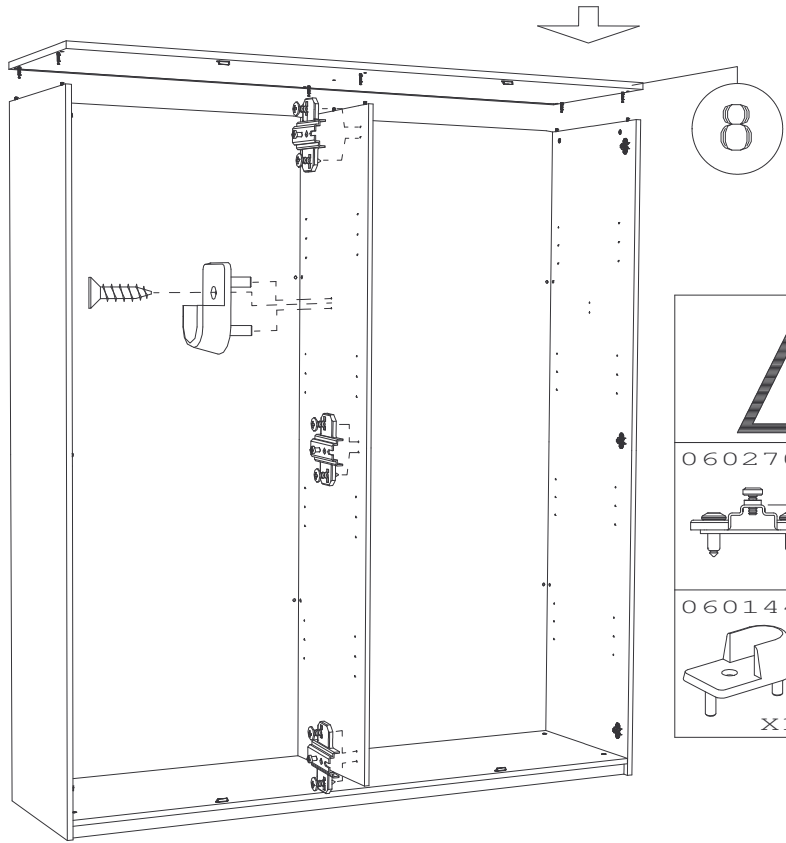
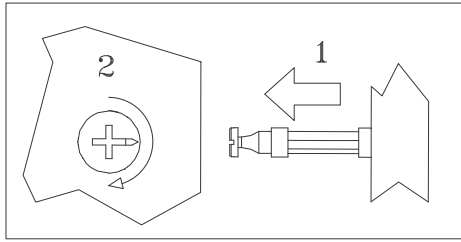
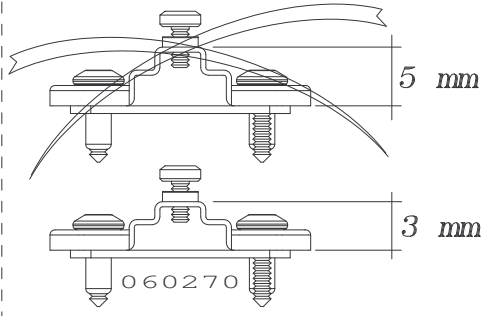
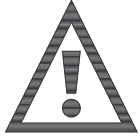

8



060270	
	3 mm
x3	
060144	062004
	3.5x15
x1	x1

18

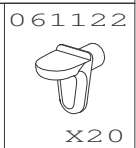
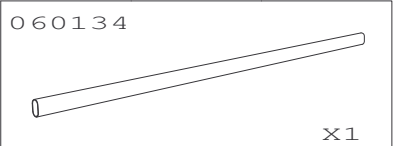
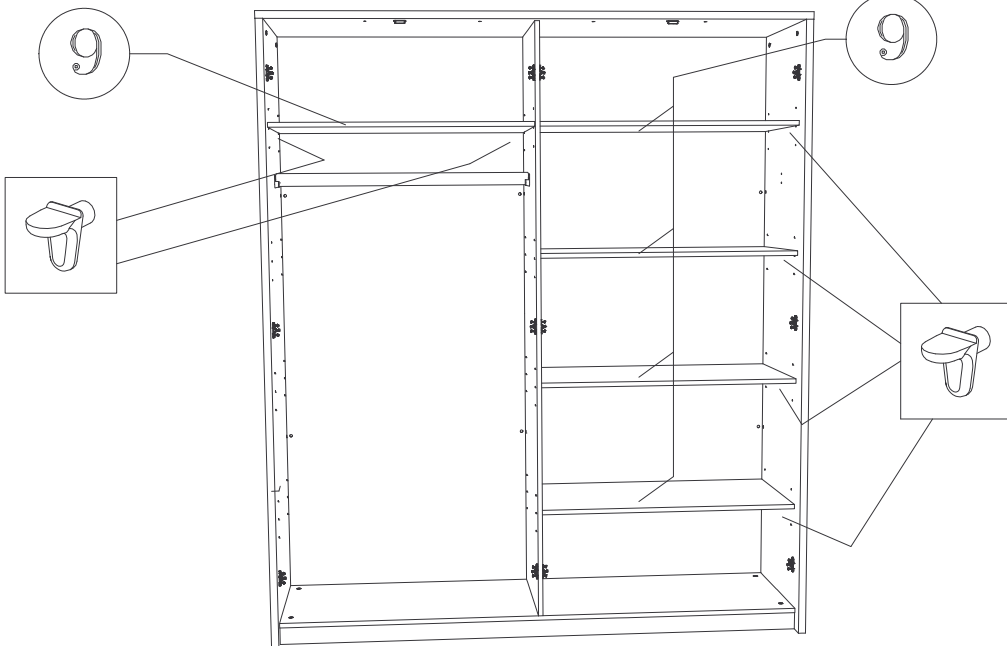

x1

x20

19

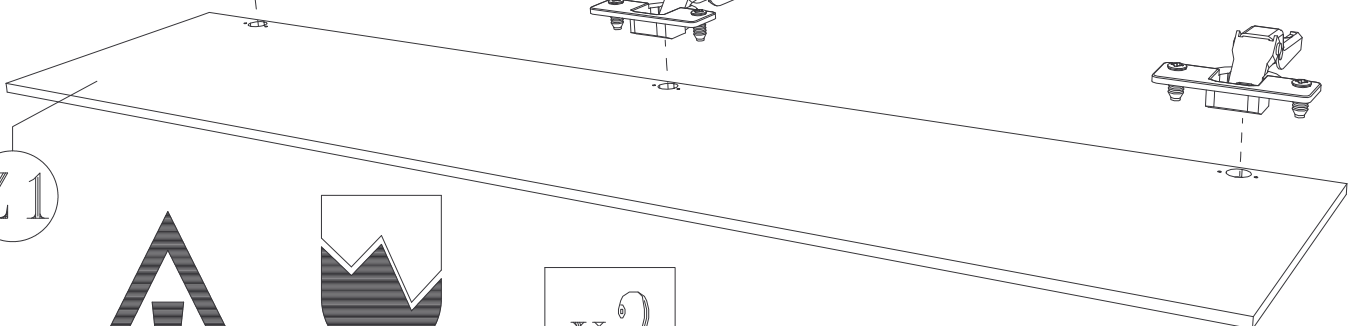
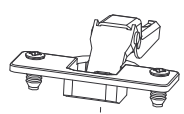
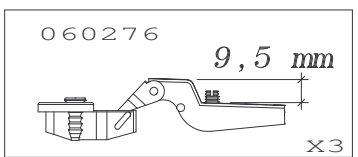
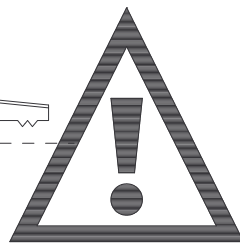
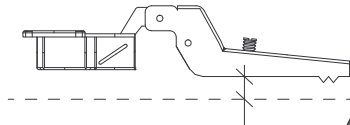
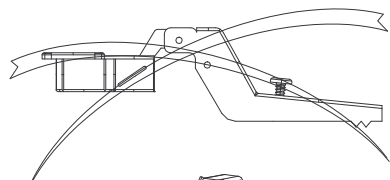

Z1

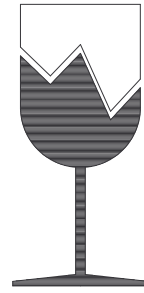
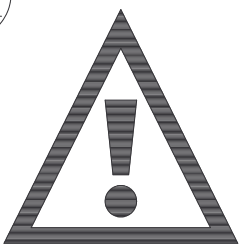

X2

20

0mm

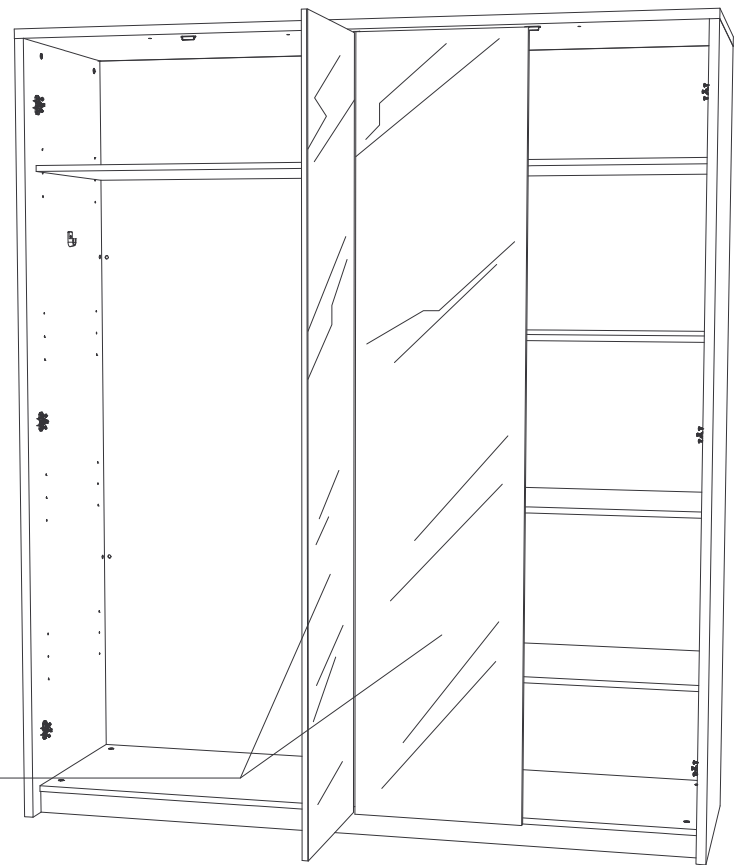
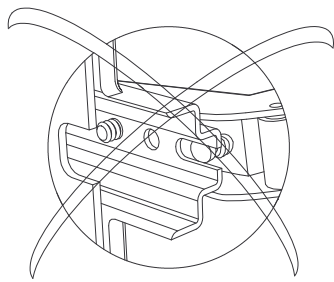
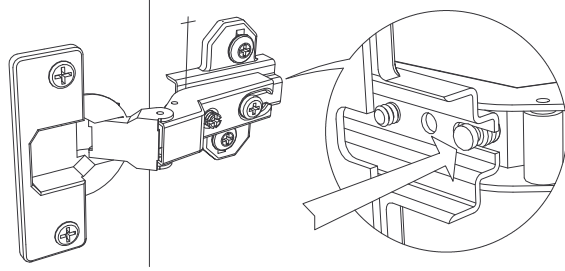

30

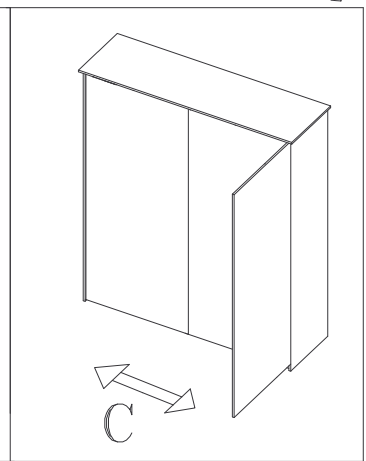
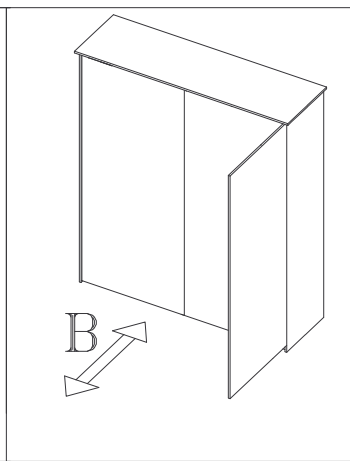
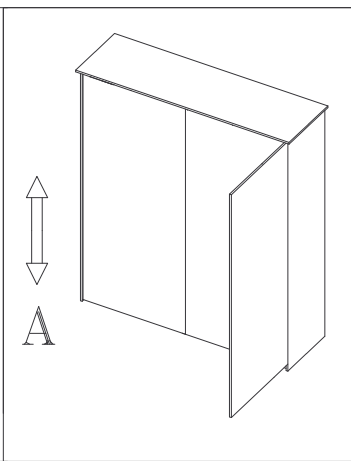
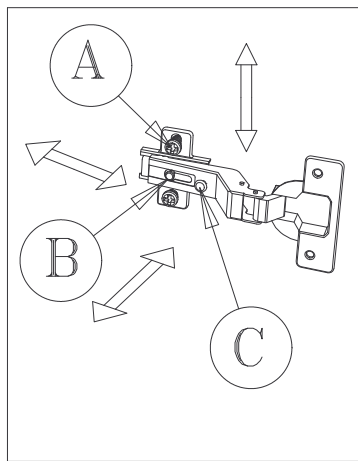

23

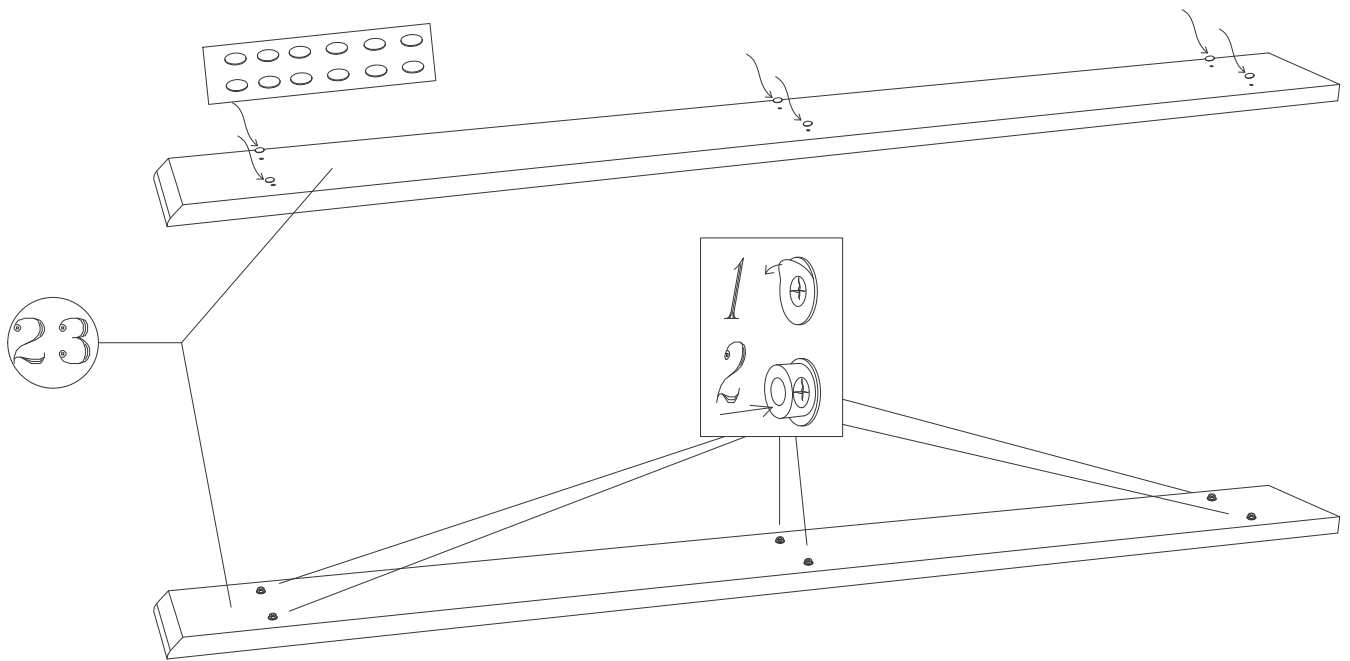
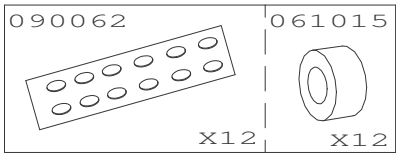

24

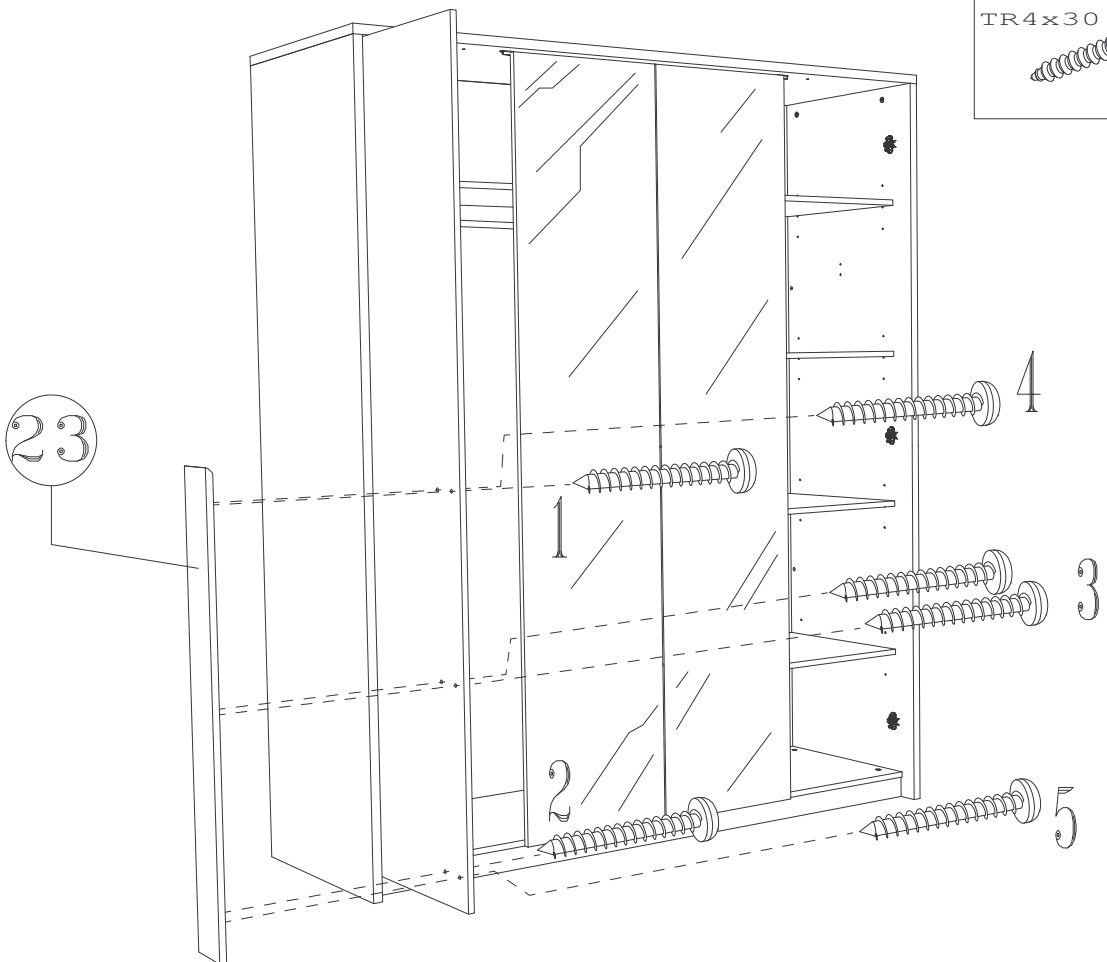
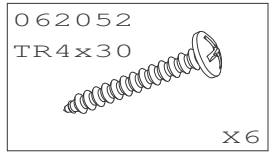

25

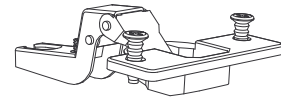
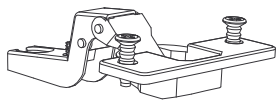
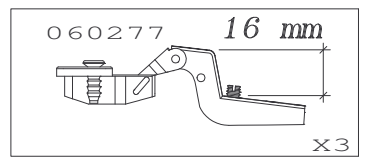
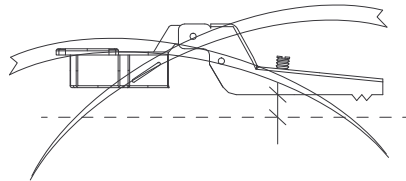
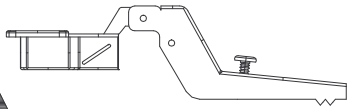
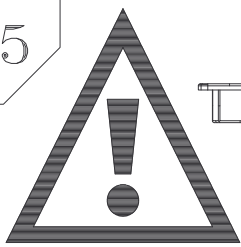

11

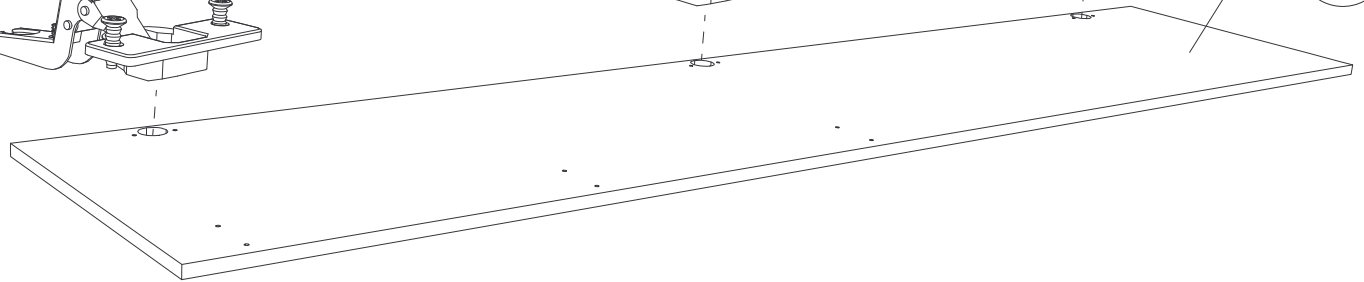

26

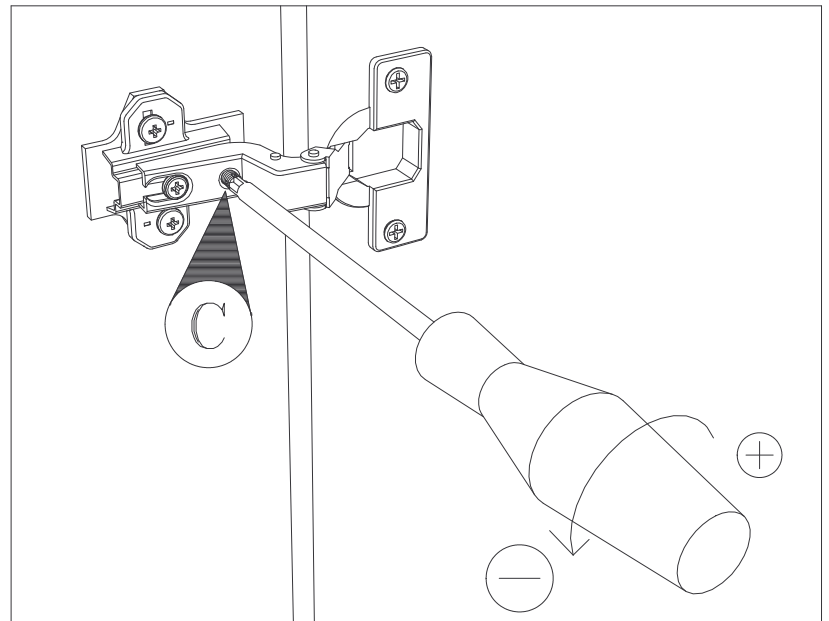
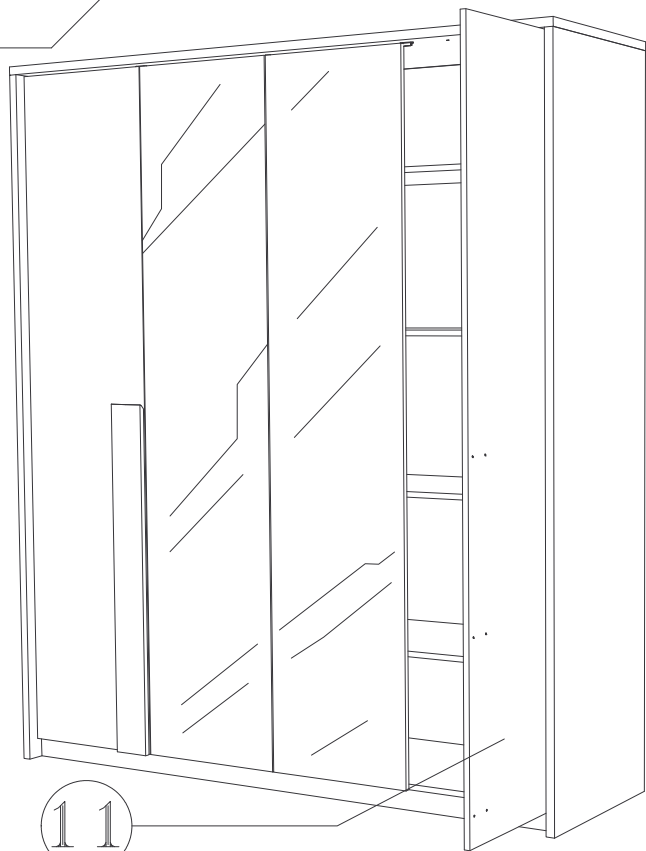

11

11

4.5MM  
NON / NO

11

2.5mm  
OUI / YES

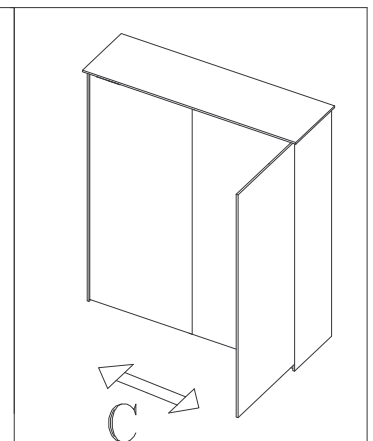
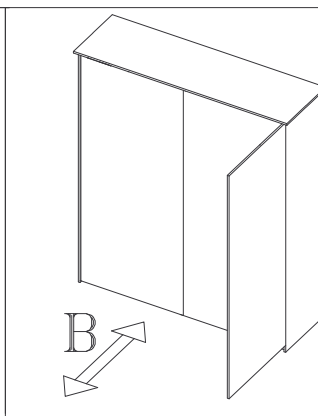
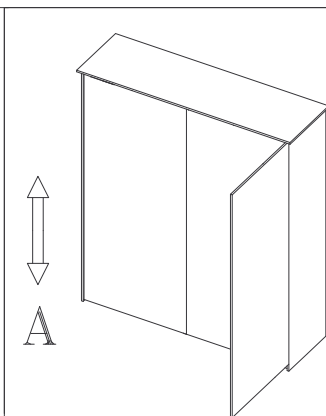
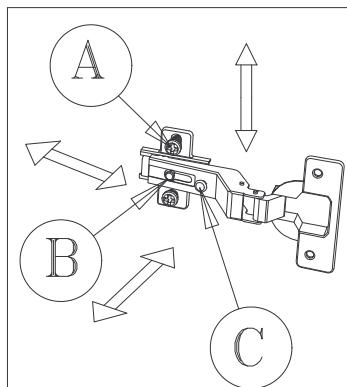

27

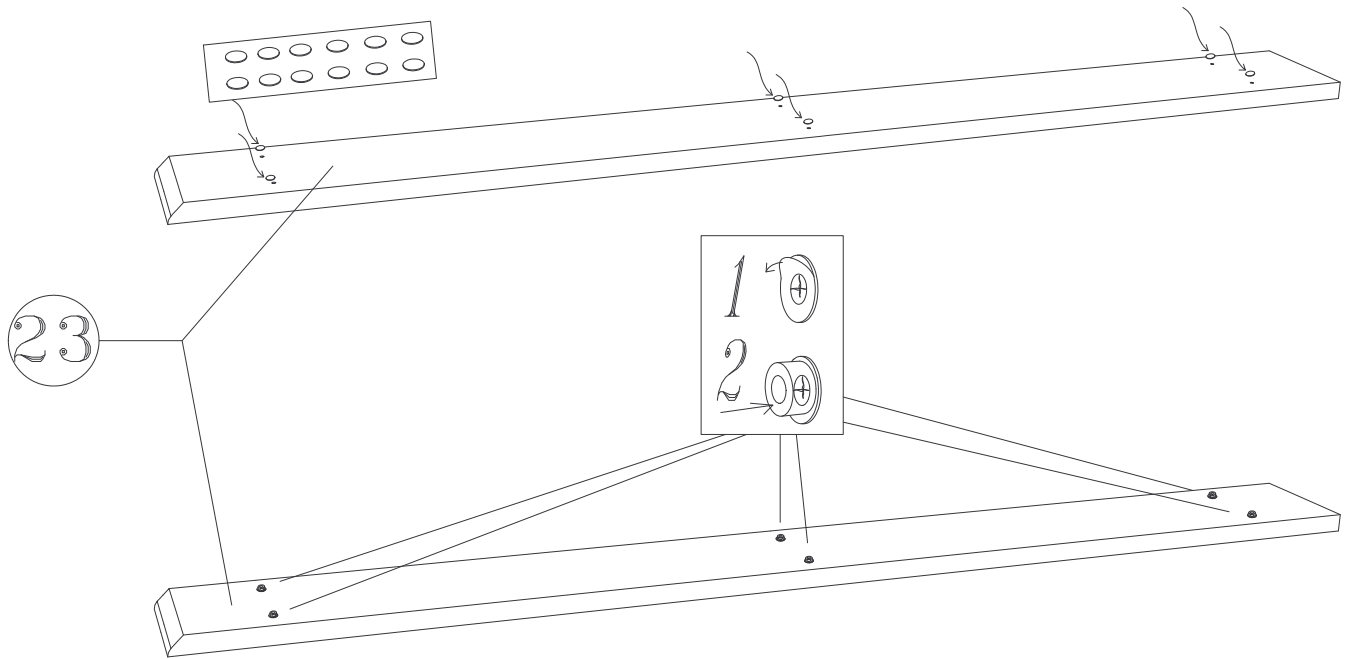
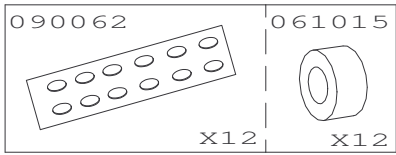

28

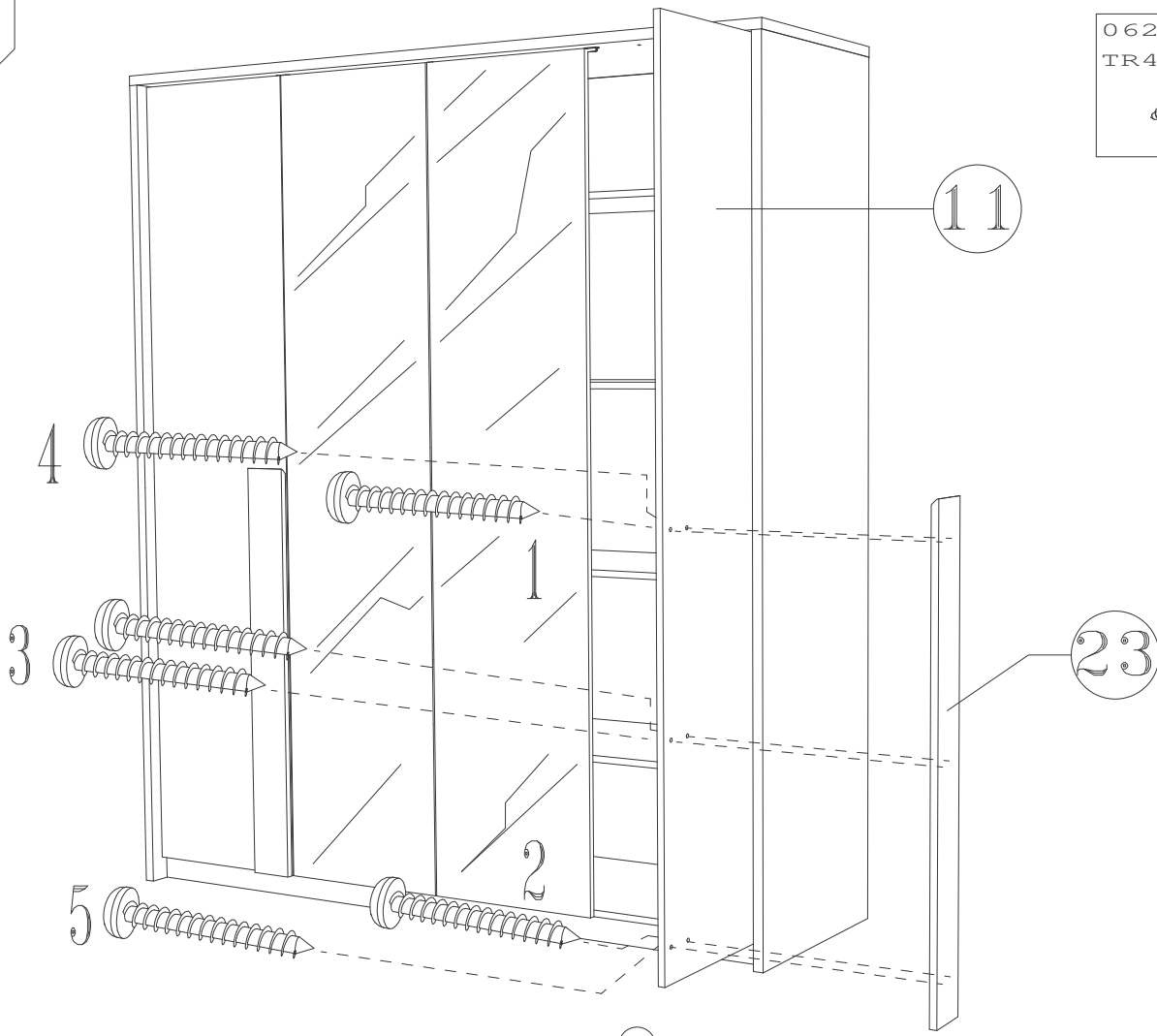
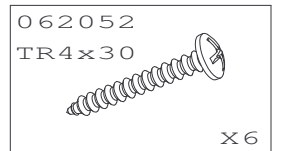

YES

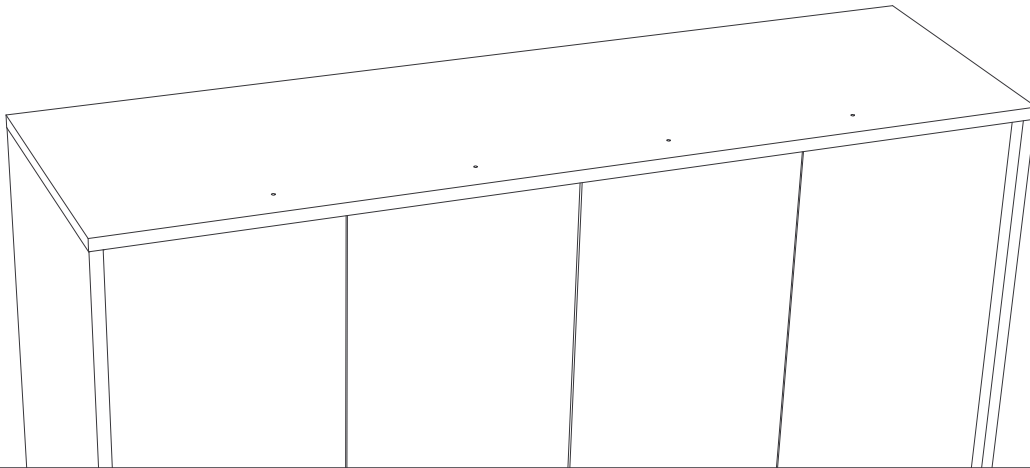
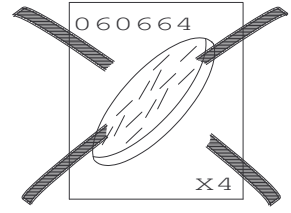
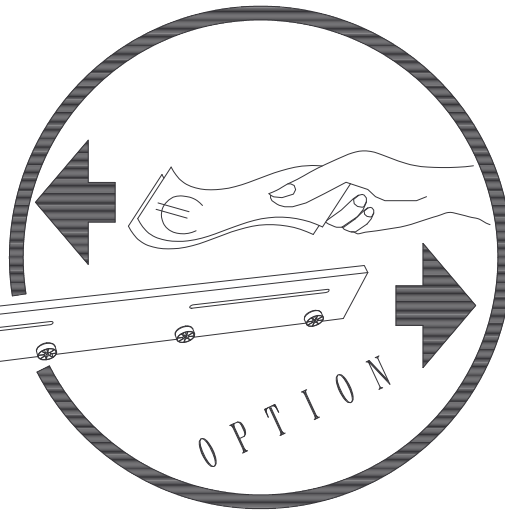

NO

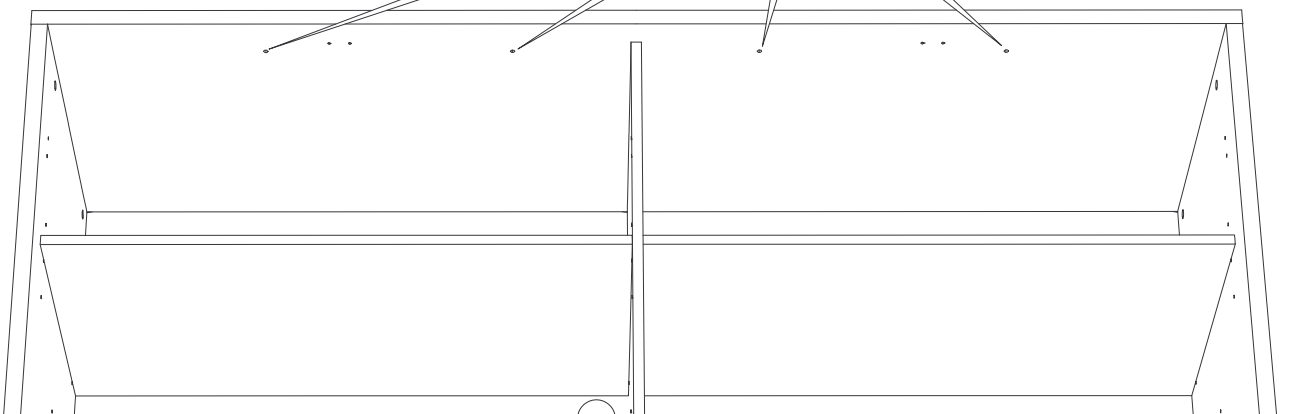
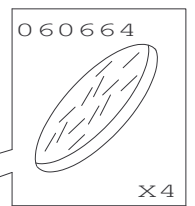
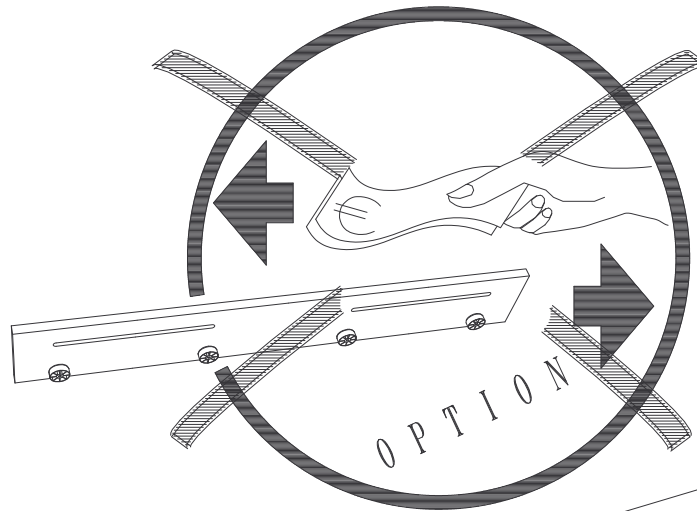

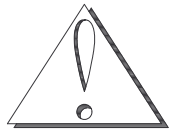
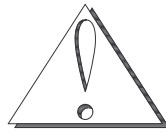
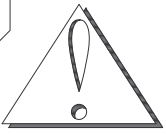

Il existe une grande diversité de types de murs ou cloisons, c'est la raison pour laquelle nous ne pouvons vous fournir le type exact de fixation. Il est nécessaire d'identifier le type de paroi à laquelle vous allez fixer ce produit afin de vous procurer les fixations appropriées. Voici quelques exemples de fixations conseillées pour :

### LES MURS PLEINS

CHEVILLE NYLON  
"FISCHER"

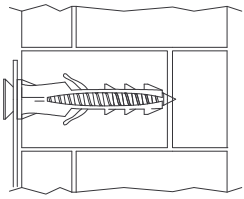
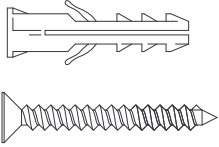

CHEVILLE D'ANCRAGE  
METAL

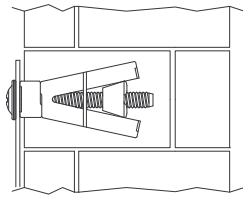
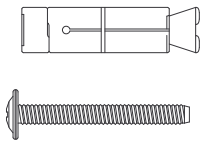

### LES CLOISONS CREUSES

CHEVILLE D'ANCRAGE  
A AILETTES EN NYLON

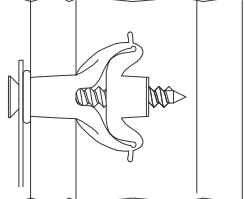
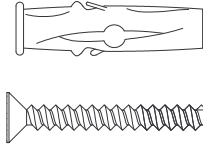

CHEVILLE METALLIQUE  
A EXPANSION

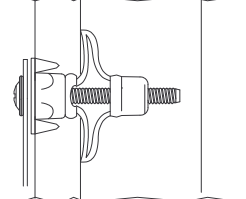
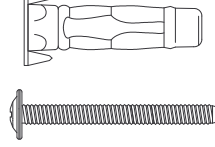

CHEVILLE "MOLLY"

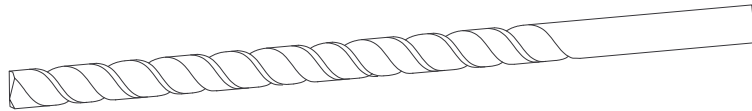
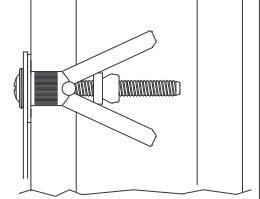
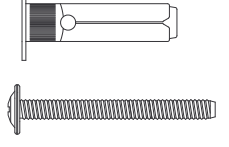

Utiliser une taille de forêt adaptée à la quincaillerie utilisée et au type de mur.

**F** L'ÉQUIPEMENT DES PIÈCES ET LE MONTAGE DU MEUBLE DOIVENT ÊTRE RÉALISÉS SUR UN PLAN DE TRAVAIL PROPRE ET PROTÉGÉ.  
LORS DE L'UTILISATION, PROTÉGER LE VERNIS DES RAYURES ET DES TACHES.  
DÉPOUSSIÉRER LES MEUBLES AVEC UN CHIFFON PROPRE, DOUX ET SEC.

**GB** Parts fitting and assembling should be realized on a clean and well protected work top.  
For use, please protect the lacquer from scratches and spillings.  
Dust each furniture items with a soft, clean, dry cloth. Do not use abrasive cleaners.

**D** Das Montage der Teile und der Möbel sollen auf ein sauber und geschützte Arbeitsplatz gemacht sein.  
Schützen Sie das Lack vor Kratzer und Flecke wenn benützung.  
Stauben Sie die Möbel mit ein trockenes, sauber, weiches, Staubtuch ab.

**E** La instalacion de las piezas y el montaje del mueble han de realizarse sobre un plano limpio y protegido.  
Al usar, hay que proteger el barniz de rayas y manchas.  
No se olvida desempolvar los muebles con un trapo limpio, suave y seco.

**P** O equipamento das peças e a montagem devem ser feitos num plano de trabalho limpo e protegido.  
Durante a utilização, proteger o verniz das manhueros e das manchas.  
Limpar o po com pano limpo e macio e seco.

**RU** Сборка частей и монтаж мебели должны производиться на освобожденном и подготовленном месте.  
В течение эксплуатации стола беречь лак от царапин и пятен.  
Стирать пыль с мебели чистой, мягкой и сухой тканью.

**CN** 零部件装备和家具安装必须在洁净、有保护的操作台上进行  
使用桌面时注意表漆，避免产生刮痕和污点  
用干净、柔软的干抹布除去家具表面的灰尘

#### GARANTIE

**F** SI VOUS CONSTATEZ UNE ÉVENTUELLE ANOMALIE, PRÉCISEZ LA NATURE DU DÉFAUT SUR CETTE FICHE ET RETOURNEZ-LA AU MAGASIN QUI VOUS A VENDU LE MEUBLE. CE DOCUMENT NOUS SERA IMMÉDIATEMENT TRANSMIS.

#### GARANTY

**GB** IN THE UNLIKELY EVENT OF THERE BEING A MANUFACTURING OR MATERIAL DEFECT, PLEASE CONTACT THE RETAILER FROM WHOM YOU PURCHASED OUR FURNITURE WITHOUT DELAY. STEPS WILL THEN BE TAKEN TO EFFECT EARLY REMEDICAL ACTION.

#### GARANTIE

**D** SOLLTEN SIE EVENTUELL EINEN MANGEL FESTSTELLEN SO BITTEN WIR SIE, UNS DIESEN NACHSTEHEND ZU BESCHREIBEN UND DIESES BLATT IHREM LIEFERANTEN ZUZUSENDEN.

#### GARANTIA

**E** SI USTED OBSERVA ALGUNA EVANTUAL ANOMALIA, EXPLIQUE EL INDOLE DEL DEFECTO Y DEVUELVA LA FICHA A LA TIENDA DONDE HA COMPRADO EL MUEBLE QUE NOS LA HARA SEGUIR.

#### GARANTIA

**P** SE DETECTAREM UMA EVENTUAL ANOMALIA, DEFINA A NATUREZA DO DEFEITO NESTA FICHA E DEVOLVAM A LOJA QUE LHE VENDEU OS MOVEIS, ESTE DOCUMENTO NOS SERA IMEDIATAMENTE TRANSMITIDO.

#### ГАРАНТИЯ :

**RU** ЕСЛИ ВЫ ВДРУГ ОБНАРУЖИЛИ ДЕФЕКТЫ МАТЕРИАЛА ИЛИ ПРОИЗВОДСТВА, ТОЧНО ОПИШИТЕ ДЕФЕКТ НА ЭТОМ ЛИСТЕ И ОБРАТИТЕСЬ В МАГАЗИН. В КОТОРОМ ВЫ КУПИЛИ МЕБЕЛЬ. ЭТОТ ДОКУМЕНТ БУДЕТ НЕМЕДЛЕННО НАМ ПЕРЕДАН И НАМИ РАССМОТРЕН

#### 保证

**CN** 如果您发现产品存在制造或是材质问题，请尽快联系您的购买商店，以便我们及时向您反馈。

NOM - NAME : \_\_\_\_\_

N° REF : \_\_\_\_\_

ADRESSE - ADDRESS : \_\_\_\_\_

DEFAUT - DEFAULT : \_\_\_\_\_

\_\_\_\_\_

\_\_\_\_\_