

**EXERPEUTIC**  
THERAPEUTIC FITNESS

# Upright Bike

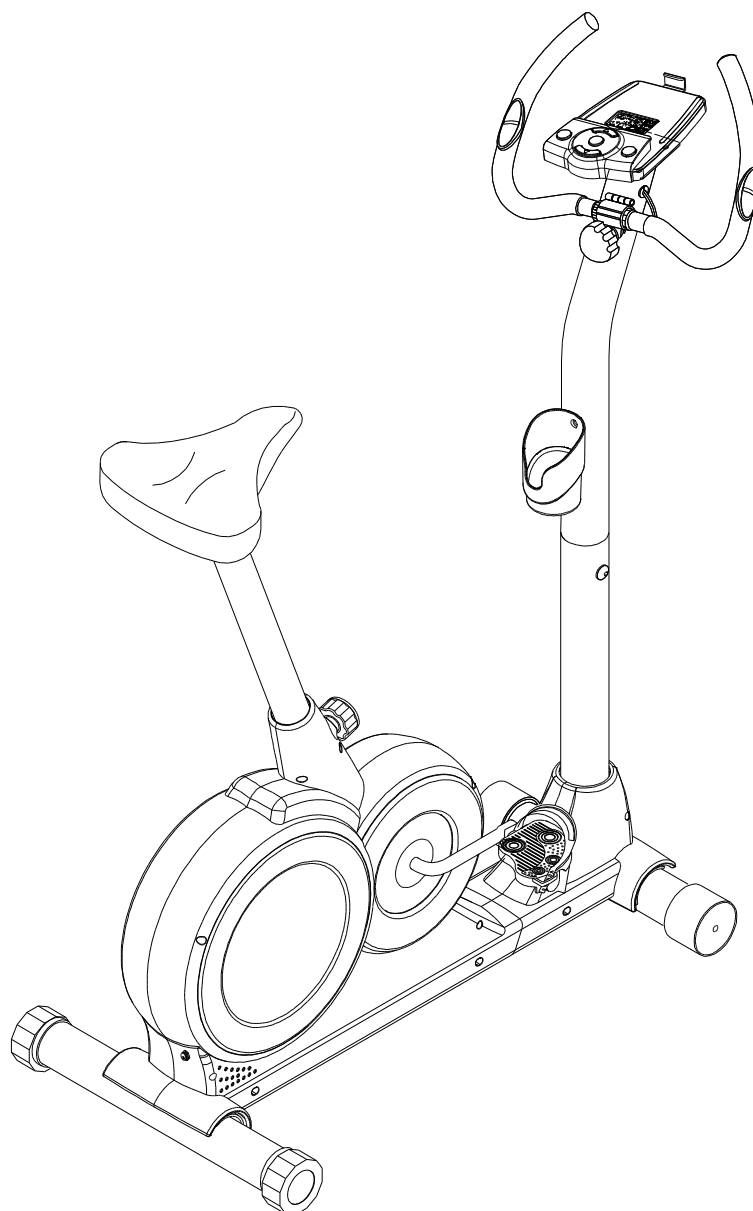

**IMPORTANT:** Read all instructions carefully before using this product.  
Retain this owner's manual for future reference.  
The specifications of this product may vary from this photo, subject to change  
without notice.

**OWNER'S MANUAL**

Item #1205

# TABLE OF

SERVICE .....	2
LABEL PLACEMENT .....	3
PRODUCT SAFETY .....	4
OVERVIEW DRAWING .....	5
PARTS LIST .....	6
HARDWARE LIST & TOOLS .....	8
ASSEMBLY .....	9
COMPUTER .....	18
ADJUSTMENTS .....	26
TROUBLE SHOOTING & MAINTENANCE .....	27
WARM UP .....	28
WARRANTY .....	29
FAX FORM .....	30

## SERVICE

### **IMPORTANT: FOR NORTH AMERICA ONLY**

**To request product service and order replacement parts, please call our customer service department at:  
1-866-924-1688**

Monday through Friday, 8:00 AM-5:00 PM Pacific Standard Time,  
or email us at: [service@paradigmhw.com](mailto:service@paradigmhw.com)  
Please visit our website at [www.paradigmhw.com](http://www.paradigmhw.com).

**Please have the following information ready when requesting for service:**

- Your name
- Phone number
- Model number
- Serial number
- Part number
- Proof of Purchase

**\*Before returning this product to the store please contact customer service at the contact number.**

Paradigm Health & Wellness, Inc.  
1189 Jellick Ave.  
City of Industry, CA 91748, USA

# LABEL



**⚠ WARNING**  
 Maximum weight capacity is 300lbs  
**⚠ AVERTISSEMENT**  
 Le poids maximum pour ce produit est 136 kgs

Under Penalty of law this tag not to be removed except by the consumer

**ALL NEW MATERIAL  
 CONSISTING OF**

**POLYURETHANE FOAM PAD...100%**

**REGISTRY NO.  
 151321**

Certification is made by the manufacturer that the materials in this article are described in accordance with law.

Paradigm Fitness Equipment, Inc.  
 1189 Jellick Ave.  
 City of Industry, CA 91748 USA

## NOTICE

THIS ARTICLE DOES NOT MEET THE FLAMMABILITY REQUIREMENTS OF CALIFORNIA BUREAU OF HOME FURNISHINGS TECHNICAL BULLETIN 117. CARE SHOULD BE EXERCISED NEAR OPEN FLAME OR WITH BURNING CIGARETTES.

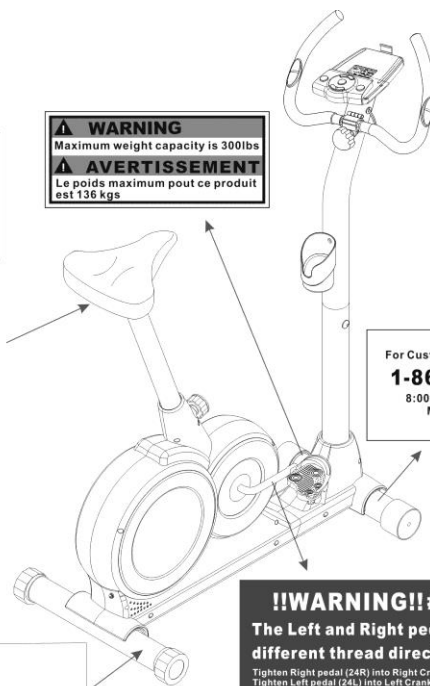

For Customer Assistance Call:  
**1-866-924-1688**  
 8:00 am- 5:00 pm (PST)  
 Monday to Friday

Pour le service à la clientèle composer le:  
**1-866-924-1688**  
 Du lundi au vendredi  
 8:00 h-17 h (HNP)

## !!WARNING!! #1205

**The Left and Right pedals have different thread directions.**

Tighten Right pedal (24R) into Right Crank clockwise!  
 Tighten Left pedal (24L) into Left Crank counter-clockwise!

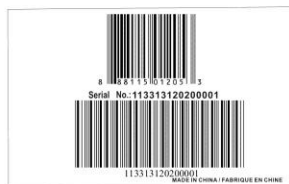

## PRODUCT SAFETY

**Basic precautions should always be followed, including the following safety instructions when using this equipment. Read all instructions before using this equipment.**

1. Read all the instructions in this manual and do warm up exercises before using this equipment.
2. Before exercise, in order to avoid injuring the muscle, warm-up exercise of every position of the body is necessary. Refer to Warm Up pages. After exercise, relaxation of the body is suggested for cool-down.
3. Please make sure all parts are not damaged and fixed well before use. This equipment should be placed on a flat surface when using. Using a mat or other covering material on the ground is recommended.
4. Please wear proper clothes and shoes when using this equipment; do not wear clothes that might catch any part of the equipment; remember to tighten the pedaling straps.
5. Do not attempt any maintenance or adjustments other than those described in this manual. Should any problems arise, discontinue use and consult an *Authorized Service Representative*.
6. Do not use the equipment outdoors.
7. This equipment is for household use only.
8. Only one person should be on the equipment while in use.
9. Keep children and pets away from the equipment while in use. This machine is designed for adults only. This product requires a minimum of 6 feet of space for safe operation.
10. If you feel any chest pains, nausea, dizziness, or short of breath, you should stop exercising immediately and consult your physician before continuing.
11. The maximum weight capacity for this product is 300 lbs/136 kgs.

**WARNING:** Before beginning any exercise program consult your physician. This is especially important for the people who are over 35 years old or who have pre-existing health problems. Read all instructions before using any fitness equipment.

**CAUTION:** Read all instructions carefully before operating this product. Retain this Owner's Manual for future reference.

# OVERVIEW

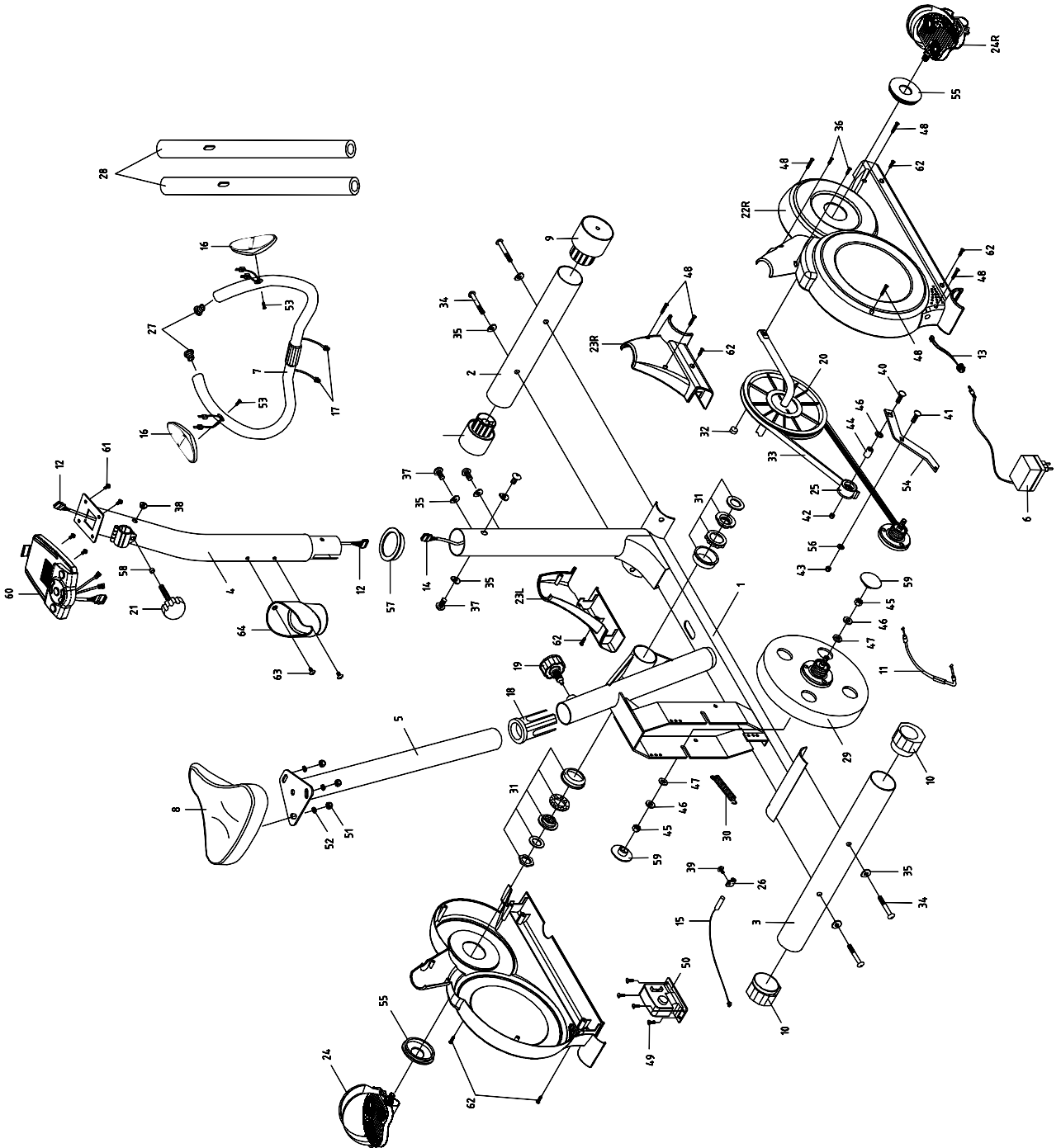

## PARTS LIST

No.	Description	Qty	No.	Description	Qty
001	Main Frame	1	024L	Left Foot Pedal	1
002	Front Stabilizer Ø60x1.5tx380mm	1	024R	Right Foot Pedal	1
003	Rear Stabilizer Ø60x1.5tx500mm	1	025	Idle Wheel 10x36x22	1
004	Handlebar Post Ø60x1.5tx660mm	1	026	Sensor Bracket	1
005	Seat Post Ø38x1.5tx500mm	1	027	Handlebar End Cap Ø22	2
006	Adapter	1	028	Handlebar Foam Grip Ø20x5tx533mm	2
007	Handlebar Ø22x1.4t	1	029	Flywheel Ø250	1
008	Seat Cushion 35"	1	030	Spring 2.0x28	1
009	Front Stabilizer End Cap Ø60	2	031	Ball Bearing Set	1
010	Rear Stabilizer End Cap Ø60	2	032	Magnet Ø15x7mm	1
011	Magnetic Brake Cable	1	033	Belt 340J6	1
012	Extension Sensor Wire II L=750mm	1	034	Hexagon Socket Head Bolt M8x70mm	4
013	Power Supply Cable L=650mm	1	035	Curve Washer Ø21xØ8x2t	8
014	Extension Sensor Wire I L=1150mm	1	036	Self Tapping Screw M4.5x15mm	2
015	Sensor with Wire L=100mm	1	037	Hexagon Socket Head Bolt M8x15mm	4
016	Hand Pulse Sensor	2	038	Wire Plug	1
017	Hand Pulse Sensor Wire L=650mm	2	039	Bolt for Sensor Bracket M5x12mm	1
018	Seat Post Bushing Ø38x50x110mm	1	040	Carriage Bolt M10x35mm	1
019	Seat Post Knob M16x35mm	1	041	Carriage Bolt M8x20mm	1
020	Belt Pulley with Crank Ø200	1	042	Nylon Locknut M10	1
021	Handlebar Knob M8x35mm	1	043	Nylon Locknut M8	1
022L	Left Cover	1	044	Spacer Ø10xØ15x9mm	1
022R	Right Cover	1	045	Nut 3/8"x26tx9mm	2
023L	Left Decorative Cover	1	046	Washer Ø19xØ10x1.5T	3
023R	Right Decorative Cover	1	047	Washer Ø20xØ10x3T	2

## PARTS LIST

No.	Description	Qty	No.	Description	Qty
048	Self Tapping Screw M4.5x25mm	6	057	Handlebar Post Cover Ø60	1
049	Bolt M5x12mm	4	058	Spacer Ø8.5xØ13x6mm	1
050	DC Motor	1	059	Round Cover	2
051	Nylon Nut M8	3	060	Computer	1
052	Washer Ø15xØ8x1.0T	3	061	Bolt for Computer	4
053	Self Tapping Screw M4x20mm	2	062	Self Tapping Screw M5x15mm	6
054	Idler Arm	1	063	Bolt M5x15mm	2
055	Cover Cap	2	064	Bottle Holder	1
056	Washer Ø16xØ8x1.5T	1			



## HARDWARE LIST &

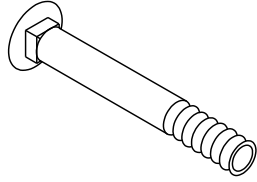

(#34) Hexagon Socket Head Bolt  
4PCS



(#35) Curve Washer  
4 PCS

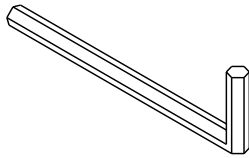

Allen Wrench  
1 PC

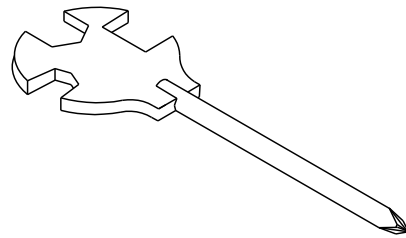

Multi Hex Tool with Phillips Screwdriver  
1 PC

# ASSEMBLY

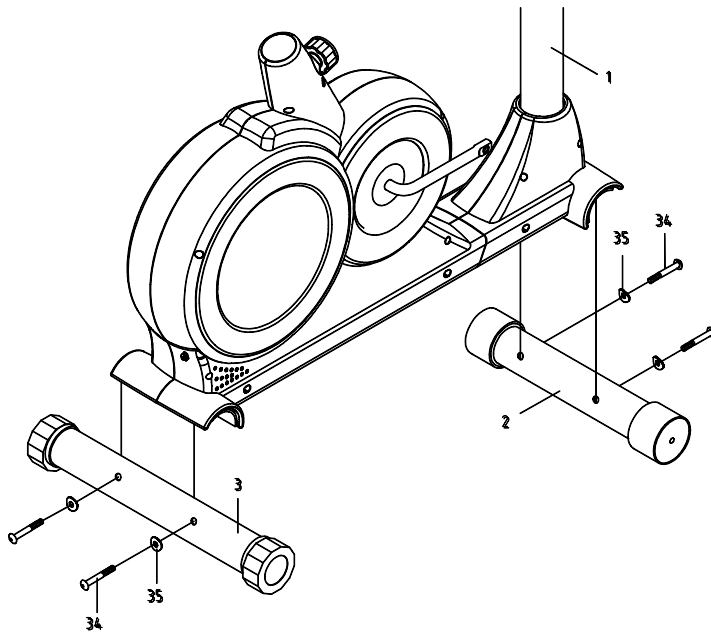

## Tool:

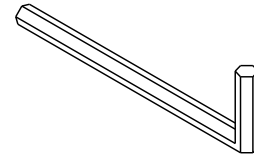

Allen Wrench

## 1. Front/Rear Stabilizers Installation

- A. Position the Rear Stabilizer (#3) behind the Main Frame (#1) and align bolt holes. Attach the Rear Stabilizer (#3) onto the rear curve of the Main Frame (#1) with two Hexagon Socket Head Bolts (#34) and two Curve Washers (#35). Tighten bolts with the Allen Wrench provided.
- B. Position the Front Stabilizer (#2) in front of the Main Frame (#1) and align bolt holes. Attach the Front Stabilizer (#2) onto the front curve of the Main Frame (#1) with two Hexagon Socket Head Bolts (#34) and two Curve Washers (#35). Tighten bolts with the Allen Wrench provided.

## Hardware:

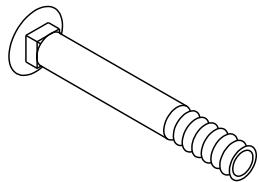

(#34) Hexagon Socket Head Bolt  
4PCS



(#35) Curve Washer  
4 PCS

# ASSEMBLY

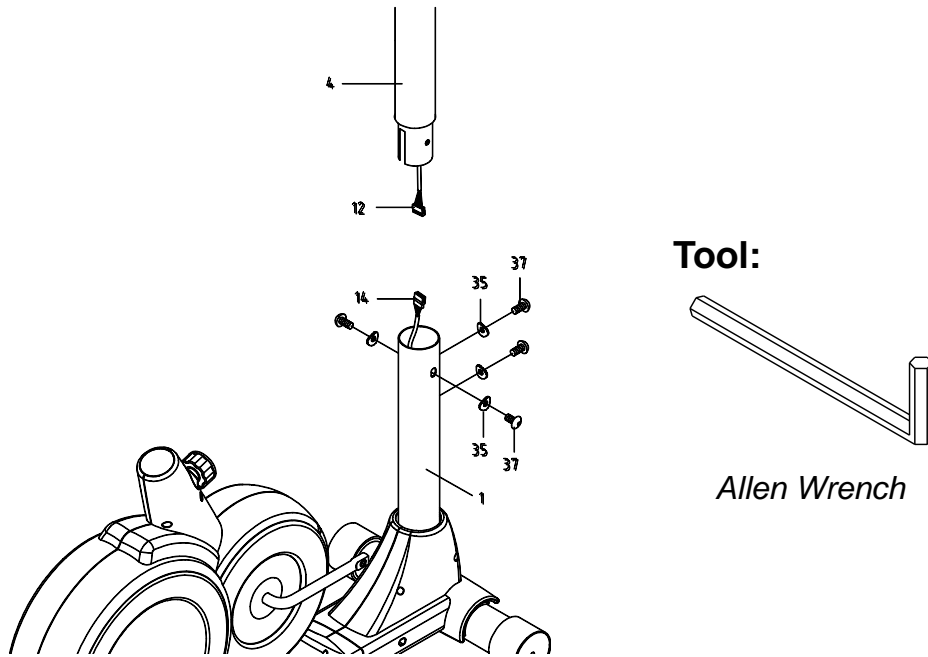

## 2. Handlebar Post Installation

Remove all four Hexagon Socket Head Bolts (#37) and four Curve Washers (#35) from the Handlebar Post (4). Remove bolts with the Allen Wrench provided.

Connect the Extension Sensor Wire II (12) in the Handlebar Post (#4) and connect to the Extension Sensor Wire I (14) in the Main Frame (#1). Insert the Handlebar Post (#4) onto the Main Frame (#1) and screw all four Hexagon Socket Head Bolts (#37) and four Curve Washers (#35) that were removed. Tighten it with the Allen Wrench provided.

# ASSEMBLY

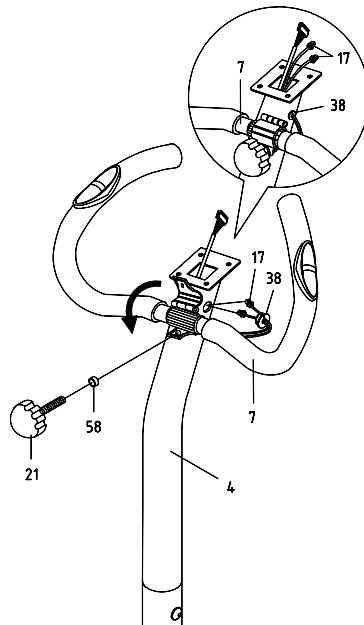

### 3. Handlebar Installation

Remove Handlebar Knob (#21) and Spacer (#58) from the Handlebar Post (#4). Remove Wire Plug (#38) from the right side of Handlebar Post (#4). Insert the Hand Pulse Sensor Wires (#17) through the Wire Plug (#38) into the hole on the Handlebar Post (#4) and then pull them out from the top of the Handlebar Post (#4). Attach the Handlebar (#7) onto the Handlebar Post (#4) with Handlebar Knob (#21) and Spacer (#58). Tighten Handlebar Knob (#21).

## ASSEMBLY

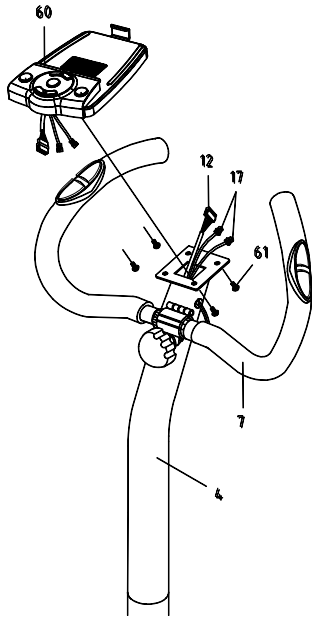

### Tool:

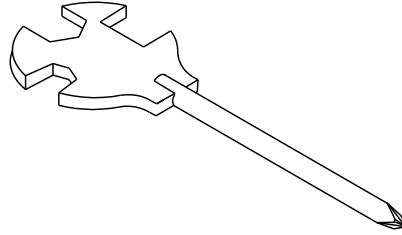

*Multi Hex Tool with Phillips Screwdriver*

### 4. Computer Installation

Remove four Bolts for Computer (#61) from the Computer (#60). Remove bolts with the Multi Hex Tool with Phillips Screwdriver provided.

Connect the Extension Sensor Wire II (12) and Hand Pulse Sensor Wires (#17) to the wires that come from the Computer (#60). Tuck wires into the Handlebar Post (#4).

Attach the Computer (#60) onto the top end of the Handlebar Post (#4) with four Bolts for Computer (#61) that were removed. Tighten bolts with the Multi Hex Tool with Phillips Screwdriver provided.

# ASSEMBLY

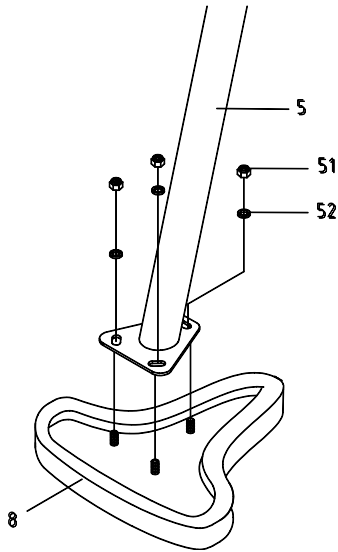

**Tool:**

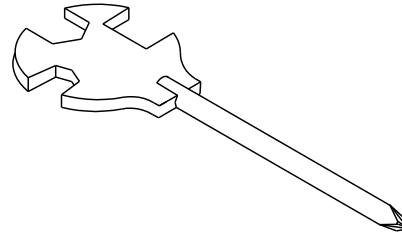

*Multi Hex Tool with Phillips Screwdriver*

## **5. Seat Cushion Installation**

Remove three Washers (#52) and three Nylon Nuts (#51) from underside of the Seat Cushion (#8). Remove nylon nuts and washers with the Multi Hex Tool with Phillips Screwdriver provided.

Guide bolts on underside of the Seat Cushion (#8) through holes on top of the Seat Post (#5), attach with three removed Washers (#52) and Nylon Nuts (#51). Tighten nylon nuts and washers with the Multi Hex Tool with Phillips Screwdriver provided.

## ASSEMBLY

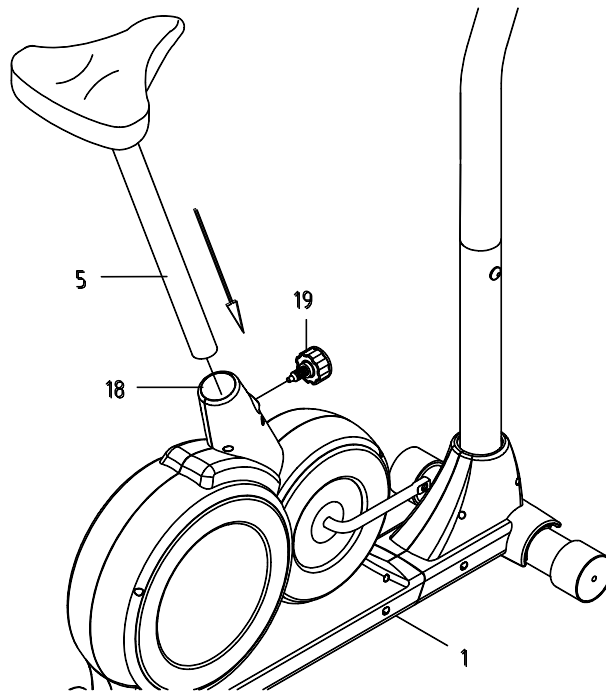

### 6. Seat Post Installation

Turn the Seat Post Knob (#19) in a counterclockwise direction until it can be pulled out. Pull out the Seat Post Knob (#19) and then slide the Seat Post (#5) into the Seat Post Bushing (#18) on the tube of the Main Frame (#1). Slide the Seat Post (#5) up or down direction to the suitable position. Lock the Seat Post (#5) in place by releasing the Seat Post Knob (#19) and sliding the Seat Post (#5) up or down slightly until the Seat Post Knob (#19) "pops" down into the locked position. For added safety, tighten the Seat Post Knob (#19) in a clockwise direction.

# ASSEMBLY

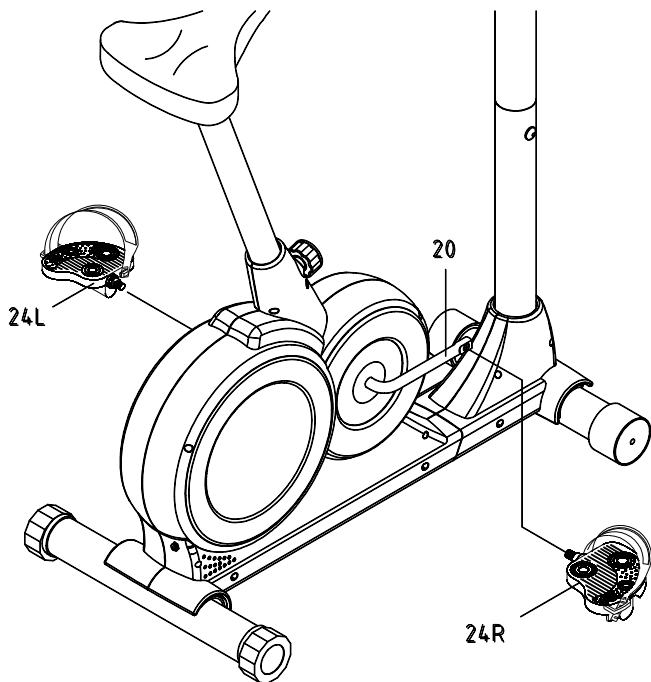

**Tool:**

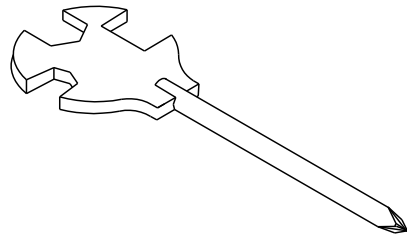

*Multi Hex Tool with Phillips Screwdriver*

## 7. Foot Pedals Installation

**The Cranks, Pedal Shafts, and Foot Pedals are marked “R” for Right and “L” for Left.**

A. Insert the pedal shaft of Left Foot Pedal (#24L) into threaded hole in the left Crank (#20).

Turn the pedal shaft by hand in the counter-clockwise direction until snug. Tighten the pedal shaft of Left Foot Pedal (#24L) with the Multi Hex Tool with Phillips Screwdriver provided.

**Note: DO NOT turn the pedal shaft in the clockwise direction, doing so will strip the threads.**

B. Insert pedal shaft of Right Foot Pedal (#24R) into threaded hole in right Crank (#20).

Turn the pedal shaft by hand in the clockwise direction until snug. Tighten pedal shaft of Right Foot Pedal (#24R) with the Multi Hex Tool with Phillips Screwdriver provided.

**Note: DO NOT turn the pedal shaft in the counter-clockwise direction, doing so will strip the threads.**



# ASSEMBLY

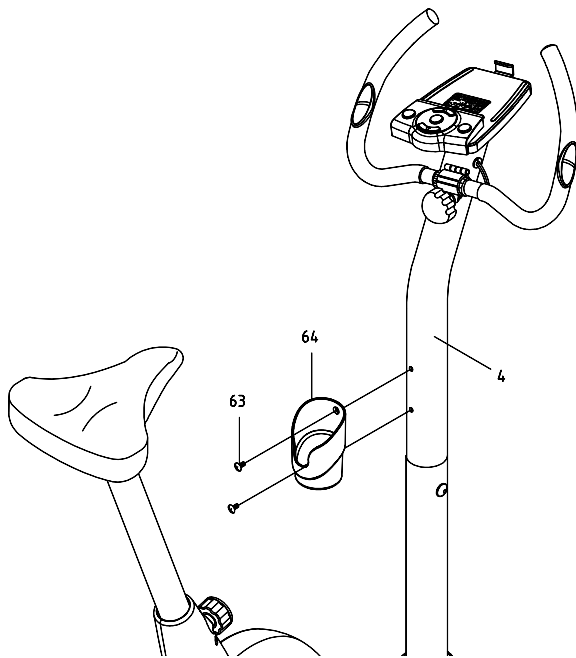

**Tool:**

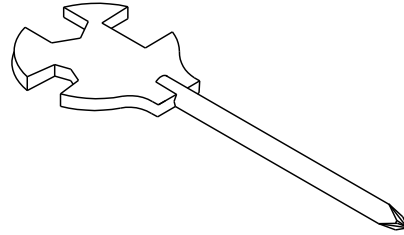

*Multi Hex Tool with Phillips Screwdriver*

## **8. Bottle Holder Installation**

Remove two Bolts (#63) from the Handlebar Post (#4). Remove bolts with the Multi Hex Tool with Phillips Screwdriver provided. Attach the Bottle Holder (#64) onto the Handlebar Post (#4) with two Bolts (#63) that were removed. Tighten bolts with the Multi Hex Tool with Phillips Screwdriver provided.

# ASSEMBLY

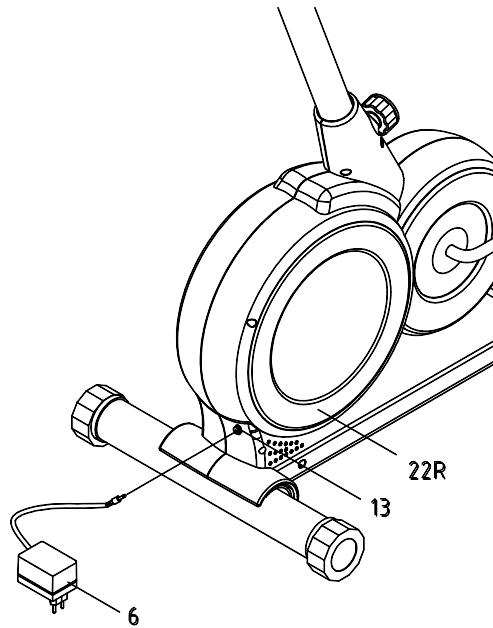

## 9. Adapter Installation

Connect the Adapter (#6) to the back of the main frame into the Power Supply Cable (#13).

# COMPUTER

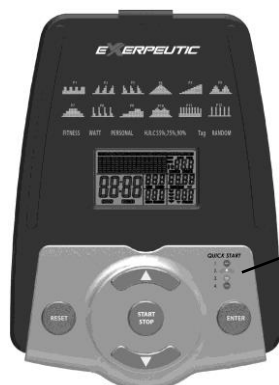

## QUICK START

1. RESET
2. UPPER ARROW
3. START STOP
4. ENTER

To quick start, press these buttons in order:

1. RESET -> 2. UPPER ARROW -> 3. START/STOP -> 4. ENTER

### I. Display:

1. The field is an individual LCD displaying:  
TIME, RPM\SPEED, DISTANCE, WATT\CALORIES, PULSE, USER.
2. Dot matrix display:
  - The LCD screen will have a single dot matrix display with 8 rows and 16 columns.
  - This dot matrix will be used to display the in work profile for the active program.

### II. Modes:

1. **POWER Mode:** When powered on, the beeper beeps a long sound, and the full screen will be display in 2 seconds, then it is into the set User mode. (As Fig-1, Fig -2)
2. **SLEEP Mode:** When rpm signal or data is not input for 4 minutes, it will automatically turn to Sleep Mode. Pedal the machine to start, or press any key to awaken the console.

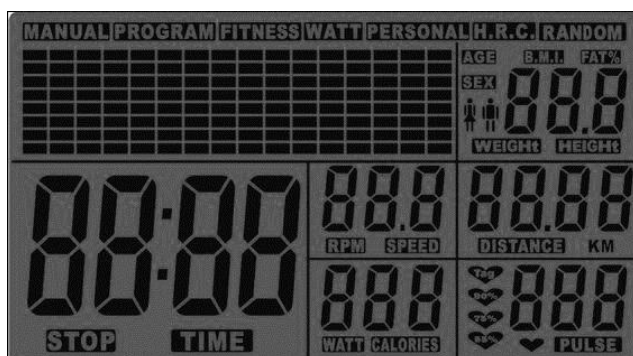

Fig - 1

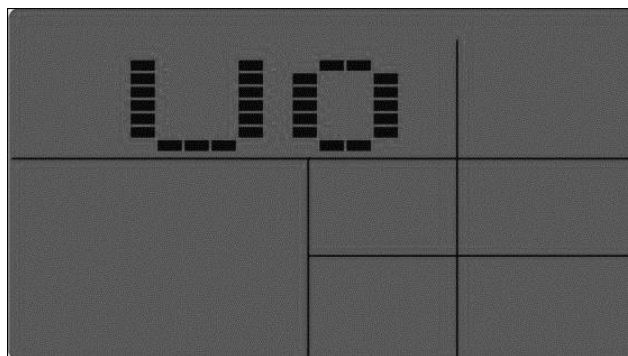

Fig - 2

# COMPUTER

## III. USER Operation instructions (U0~U4):

Select USER 0, USER 1, USER2, USER 3, USER 4:

The message reads “U0” until a selection is made. By pressing ▲ or ▼ button to choose from “U0 ~U4”.

1. Press **ENTER** button to accept “U0~U4”. By pressing the ▲ or ▼ button to adjust the **SEX** (FEMALE/MALE).
2. Press **ENTER** button to accept SEX. By pressing the ▲ or ▼ button to adjust the **AGE** value.
3. Press **ENTER** button to accept AGE. By pressing the ▲ or ▼ button to adjust the **HEIGHT (H.t)** value.
4. Press **ENTER** button to accept HEIGHT. By pressing the ▲ or ▼ button to adjust the **WEIGHT (W.t)** value.
5. Press **ENTER** button to accept WEIGHT, and into choose program instructions.

**SEX**

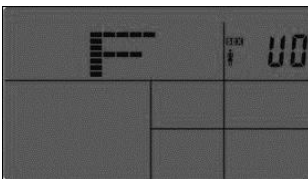

**AGE**

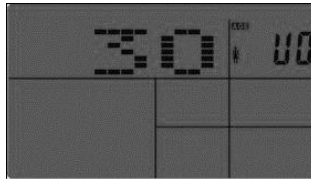

**HEIGHT**

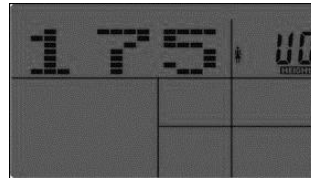

**WEIGHT**

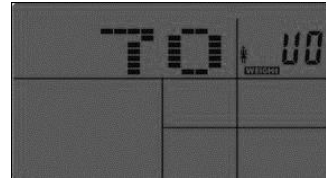

## IV. Program operation instructions:

In the choose program instructions, by pressing the ▲ or ▼ button to adjust the profiles and it can be set the circle (select programs):

**MANUAL→PROGRAM→FITNESS→WATT→PERSONAL→H.R.C. →RANDOM**

1. If Press **ENTER** button to accept **MANUAL**

By pressing the ▲ or ▼ button to adjust the **LEVEL(1-24)**.

Press **ENTER** button to accept LEVEL. By pressing the ▲ or ▼ button to adjust the **TIME** value.

Press **ENTER** button to accept TIME. By pressing the ▲ or ▼ button to adjust the **DISTANCE** value.

Press **ENTER** button to accept DISTANCE. By pressing the ▲ or ▼ button to adjust the **CALORIES** value.

## COMPUTER

2. If Press **ENTER** button to accept **PROGRAM**

By pressing the ▲ or ▼ button to adjust the **P1-P12**

Press **ENTER** button to accept program. By pressing the ▲ or ▼ button to adjust the **Profile** .

Press **ENTER** button to accept LEVEL. By pressing the ▲ or ▼ button to adjust the **TIME** value.

Press **ENTER** button to accept TIME. By pressing the ▲ or ▼ button to adjust the **DISTANCE** value.

Press **ENTER** button to accept DISTANCE. By pressing the ▲ or ▼ button to adjust the **CALORIES** value

3. If Press **ENTER** button to accept **FITNESS**

Press the **START/STOP** button and started testing, and the test time is 8 minutes.

The results as follows:

Figure	State
F1	VERY GOOD
F2	GOOD
F3	FAIR
F4	POOR
F5	VERY POOR

4. If Press **ENTER** button to accept **WATT**

By pressing the ▲ or ▼ button to adjust the **TIME** value.

Press **ENTER** button to accept TIME. By pressing the ▲ or ▼ button to adjust the **DISTANCE** value.

Press **ENTER** button to accept DISTANCE. By pressing the ▲ or ▼ button to adjust the **CALORIES** value.

5. If Press **ENTER** button to accept **PERSONAL**, and set user-defined exercise program.

By pressing the ▲ or ▼ button to adjust the first columns **LEVEL (1-24)**.

Press **ENTER** button to accept level, and into next columns level.

Press **ENTER** button for 3 seconds is save this user-defined the program, and into set the target TIME.

Pressing the ▲ or ▼ button to adjust the **TIME** value.

## COMPUTER

Press **ENTER** button to accept TIME. By pressing the **▲** or **▼** button to adjust the **DISTANCE** value.

Press **ENTER** button to accept DISTANCE. By pressing the **▲** or **▼** button to adjust the **CALORIES** value.

6. If Press **ENTER** button to accept **H.R.C. (55%, 75%, 90%, Tag)**

By pressing the **▲** or **▼** button to choose the **55%, 75%, 90% and Tag**

(1). If choose the **55%, 75% and 90%**, Press **ENTER** button to accept the mode and into set the target TIME.

By pressing the **▲** or **▼** button to adjust the **TIME** value.

Press **ENTER** button to accept TIME. By pressing the **▲** or **▼** button to adjust the **DISTANCE** value.

Press **ENTER** button to accept DISTANCE. By pressing the **▲** or **▼** button to adjust the **CALORIES** value.

(2). If choose the **Tag**, Press **ENTER** button to accept the mode and into set the target Heart.

By pressing the **▲** or **▼** button to adjust the **Heart** value, Press **ENTER** button to accept Heart.

By pressing the **▲** or **▼** button to adjust the **TIME** value.

Press **ENTER** button to accept TIME. By pressing the **▲** or **▼** button to adjust the **DISTANCE** value.

Press **ENTER** button to accept DISTANCE. By pressing the **▲** or **▼** button to adjust the **CALORIES** value.

7. If Press **ENTER** button to accept **RANDOM**

By pressing the **▲** or **▼** button to adjust the **TIME** value.

Press **ENTER** button to accept TIME. By pressing the **▲** or **▼** button to adjust the **DISTANCE** value.

Press **ENTER** button to accept DISTANCE. By pressing the **▲** or **▼** button to adjust the **CALORIES** value.

### V. Key Functions:

1. **START/STOP** button:

(1). Press this button to start workout in any sport mode;

(2). During exercising, press this key to pause the workout, then press this key to go on to exercise.

# COMPUTER

## 2. **ENTER** button:

To confirm set value and enter into the next set value.

## 3. and button:

(1). Used to change SEX, AGE, HEIGHT, WEIGHT, TIME, DISTANCE, CALORIES, TARGET HRC and LEVEL;

(2). Work level can be changed during a workout.

## 4. **RESET** button:

(1). Set in USERS state, press the button to return to select the USER mode.

(2). Set in Program state, press the button to return to the initial state of choose program.

(3). Press and hold this button for three seconds for Total Reset (go to Power Up Mode).

## VI. Functions View:

Item	Windows	Display Rang	Stored
1	<b>SEX</b>	MALE/ FEM	Yes
2	<b>AGE</b>	10-100	Yes
3	<b>WEIGHT</b>	20-330 (Lb) 10-150 (KG)	Yes
4	<b>HEIGHT</b>	36-84 (INCH) 90-210 (CM)	Yes
5	<b>TIME</b>	0:00-99:59	No
6	<b>DISTANCE</b>	0.0-99.99	No
7	<b>CALORIES</b>	0-999	No
8	<b>SPEED</b>	0.0-99.9	No
9	<b>PULSE</b>	60-200 bpm	No
10	<b>RPM</b>	0-250 rpm	No
11	<b>BRAKE RESISTANCE LEVEL</b>	L1-L24	No
12	<b>USER</b>	U0-U4	Yes

# COMPUTER

## VII. Pre-defined program profile:

• MANUAL

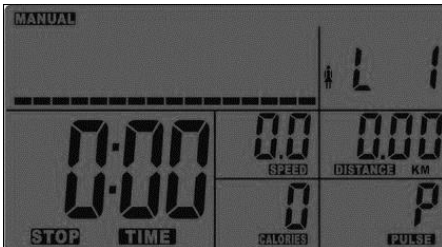

• PROGRAM

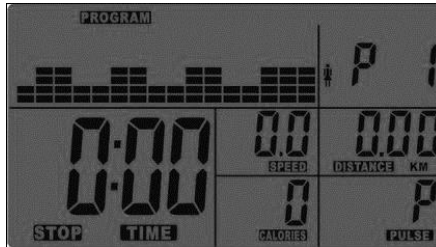

• FITNESS

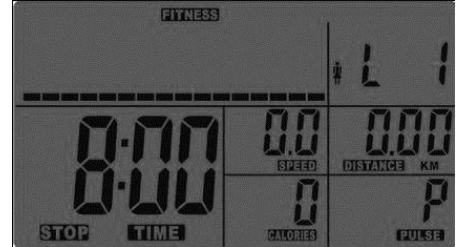

• WATT

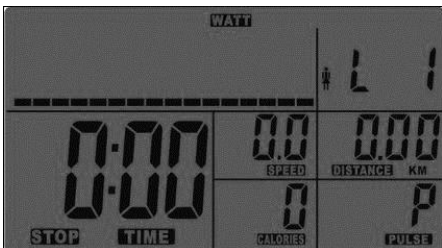

• PERSONAL

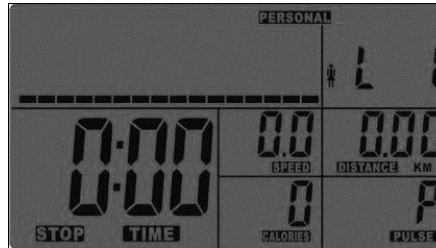

• H.R.C.

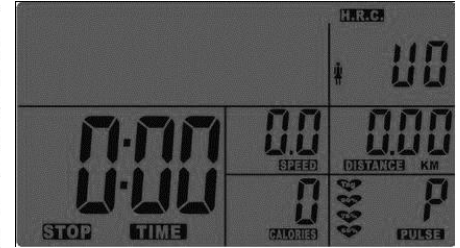

• RANDOM

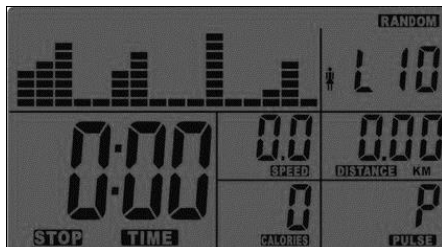

## Program Profile for the P1~P12 Program

• P1

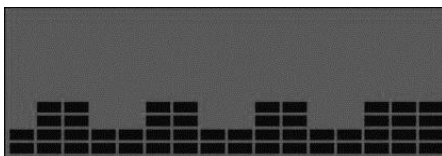

• P2

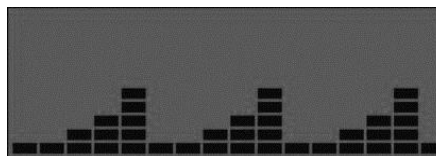

• P3

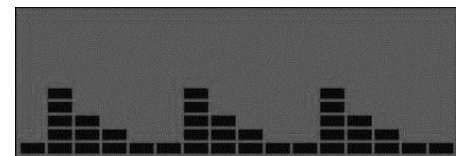



# COMPUTER

• P4

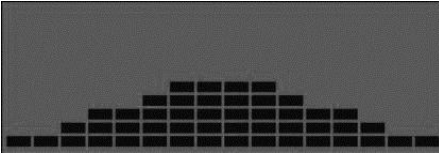

• P5

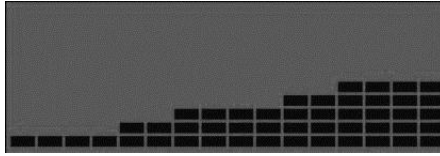

• P6

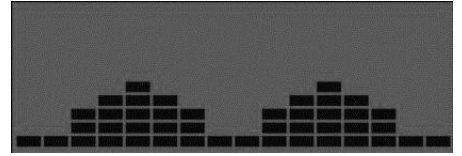

• P7

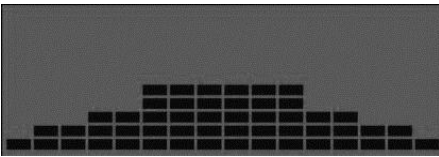

• P8

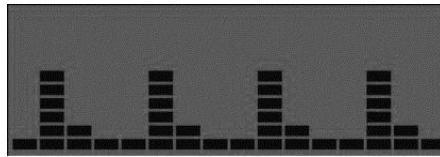

• P9



• P10

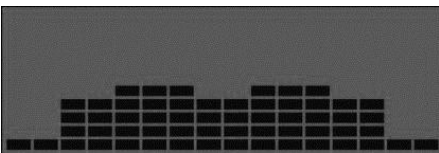

• P11

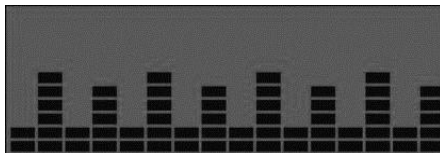

• P12

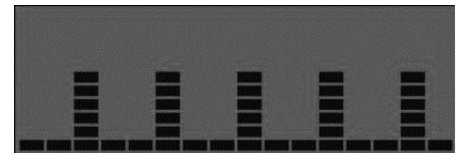

## Program Profile for the H.R.C. (55%, 75%, 90%, Tag) Program

•HRC (55%)

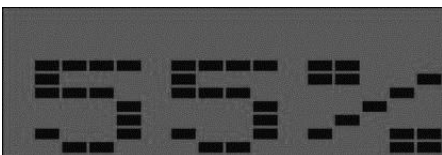

•HRC (75%)



•HRC (90%)

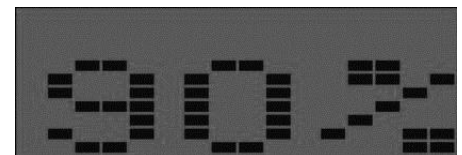

•HRC (Tag)

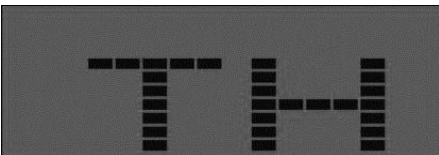

# COMPUTER

## Bluetooth Manual

Preparation: Bluetooth console, Available for both IOS and Android mobile device. Here is the Bluetooth set up example for IPOD.

1. Download APP Application

Turn on the IPOD, Go to Apple Store and “Search”. Search for “Exerpeutic pedal monitor”. Click Download. After download successfully, “Pedal Monitor” application will show on the interface.

2. After turning on the computer, it'll show the following illustration:

Turn on the Bluetooth function on the IPOD then connect to the computer.

3. Once successfully connected, select HOME then go back to Desktop:

Download “Pedal Monitor”. The screen will then appear requesting to accept the agreements. Click on guest and next step click send. It'll now take you to the exercise screen; the computer will also make a beep sound and show “BT”. Now both computer and IPOD are both connected. You can start your exercise.

Note:

- While downloading APP, there is a selection where you can request to remember the user- Id. This way you won't need to go through all steps again.
- For Android system: Exerpeutic Pedal monitor is available in Google Play

Compatible Apps: Pafers Pedal monitor, Run on earth ...

## ADJUSTMENTS

### Adjusting the Handlebar

Hold the handlebar while loosening the handlebar knob. Adjust the handlebar to the desired position and turn the handlebar knob in a clockwise direction to tighten.

**NOTE: Continue to turn the handlebar knob until the handlebar is secure before exercising.**

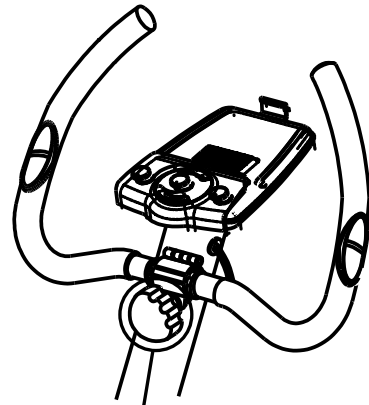

Handlebar Knob

### Adjusting the Rear Stabilizer End Cap

Turn the rear stabilizer end cap on the rear stabilizer as needed to level the upright bike.

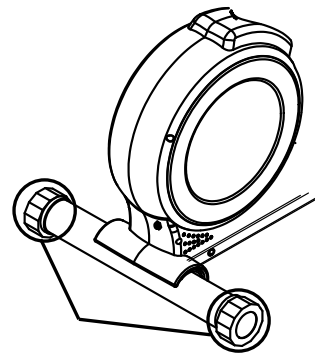

Rear Stabilizer End Cap

### Adjusting the Seat Height

Turn the seat post knob in a counterclockwise direction until it can be pulled out. Pull out the seat post knob and then slide the seat post up or down direction to the suitable position. Lock the seat post in place by releasing the seat post knob and sliding the seat post up or down slightly until the seat post knob "pops" down into the locked position.

For added safety, tighten the seat post knob in a clockwise direction.

**NOTE: When adjusting the height of seat post, make sure the seat post bushing does not exceed the mark line on the seat post.**

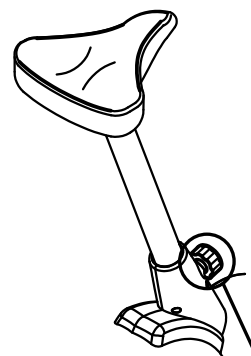

Seat Post Knob

### TROUBLE SHOOTING

**PROBLEM:** The upright bike wobbles when in use.

**SOLUTION:** Turn the rear stabilizer end cap on the rear stabilizer as needed to level the upright bike.

**PROBLEM:** There is no display on the computer console.

**SOLUTION:** Remove the computer console and verify the wires that come from the computer console are properly connected to the wires that come from the handlebar post.

**PROBLEM:** There is no heart rate reading or there is erratic / inconsistent reading.

**SOLUTION:** Make sure that the wire connections for the hand pulse sensors are secure.

**SOLUTION:** To ensure the pulse readout is more precise, always hold on to the handlebar grip sensors with two hands instead of just with one hand only.

**SOLUTION:** Avoid gripping the hand pulse sensors too tight. Try to maintain moderate pressure while holding onto the hand pulse sensors.

**PROBLEM:** The upright bike makes a squeaking noise when in use.

**SOLUTION:** The bolts may be loose on the upright bike. Please inspect all of the bolts and tighten any loose bolts.

### MAINTENANCE

#### Cleaning

The upright bike can be cleaned with a soft cloth and mild detergent. Do not use abrasives or solvents on plastic parts. Please wipe your perspiration off the upright bike after each use. Be careful not get excessive moisture on the computer display panel as this might cause an electrical hazard or electronics to fail.

Please keep the upright bike, especially, the computer console out of direct sunlight to prevent screen damage.

Please inspect all assembly bolts and pedals on the machine for proper tightness every week.

#### Storage

Store the bike in a clean and dry environment away from children.

## WARM UP

### **Quadriceps Stretch**

With one hand against a wall for balance, reach behind you and pull your right foot up. Bring your heel as close to your buttocks as possible. Hold for 15 counts and repeat with left foot up.



### **Inner Thigh Stretch**

Sit with the soles of your feet together with your knees pointing outward. Pull your feet as close into your groin as possible.

Gently push your knees towards the floor. Hold for 10 counts.



### **Toe Touches**

Slowly bend forward from your waist, letting your back and shoulders relax as you stretch toward your toes. Reach down as far as you can and hold for 15 counts.



### **Hamstring Stretches**

Sit with your right leg extended. Rest the sole of your left foot against your right inner thigh. Stretch toward your toe as far as possible. Hold for 15 counts. Relax and then repeat with left leg extended.



## WARRANTY

Paradigm Health & Wellness, Inc. warrants to the original purchaser that this product is free from defects in material and workmanship when used for the purpose intended, under the conditions that it has been installed and operated in according to Paradigm Health & Wellness, Inc.'s Owner's Manual. Paradigm Health & Wellness, Inc.'s obligation under this warranty is limited to replacing free of charge, any parts which may prove to be defective under normal home use. This warranty does not include any damage caused by improper operation, misuse or commercial application. From the date of purchase, the product is warranted to be free from defects for 1 (one) year. All parts and workmanship, including upholstery, foam, ball bearings, pulleys, cables, shocks, all tension mechanisms, wheels, pedals and hardware are to be free from manufacture defects for 90 days. This warranty is offered only to the original owner and is not transferable. Proof of purchase is required.

### **Ordering Replacement Parts**

Replacement parts can be ordered by calling or emailing our customer service department

**service@paradigmhw.com**

**1-866-924-1688**

Monday through Friday, 8:00 AM - 5:00 PM (PST).

When ordering replacement parts please have the following information ready:

- 1. Owner's Manual**
- 2. Model Number**
- 3. Description of Parts**
- 4. Part Number**
- 5. Date of Purchase**

# FAX FORM

## Paradigm Health & Wellness, Inc.

### PARTS REQUEST FAX FORM

Please fax this form to (1-626-810-2166)

OR YOU CAN EMAIL CUSTOMER SERVICE REQUESTS TO  
**service@paradigmhw.com**

NAME: \_\_\_\_\_

ADDRESS: \_\_\_\_\_

CITY \_\_\_\_\_ STATE \_\_\_\_\_ ZIP \_\_\_\_\_

TELEPHONE: (Day) \_\_\_\_\_

(Night) \_\_\_\_\_

(Email Address) \_\_\_\_\_

SERIAL#: \_\_\_\_\_

MODEL#: \_\_\_\_\_

PURCHASE DATE: \_\_\_\_\_

PURCHASE FROM: \_\_\_\_\_

PART #	DESCRIPTION	QTY

***"YOUR ORDER WILL BE PROCESSED WITHIN 3 BUSINESS DAYS"***

<b>OFFICIAL USE ONLY</b>
SHIP DATE: _____
TRK #: _____
BACK ORDER: _____