

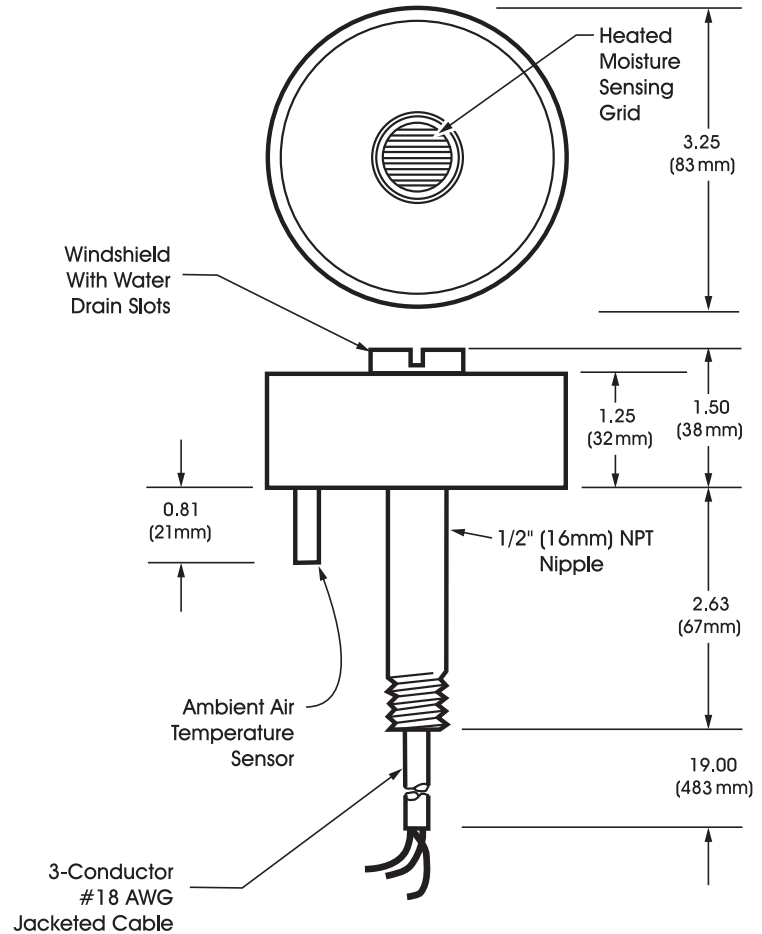

FEATURES & BENEFITS

- Minimizes snow melting operation cost
- Reliable snow sensing
- Senses both ambient temperature and precipitation
- Application flexibility
- Simple installation
- Field proven in thousands of installations

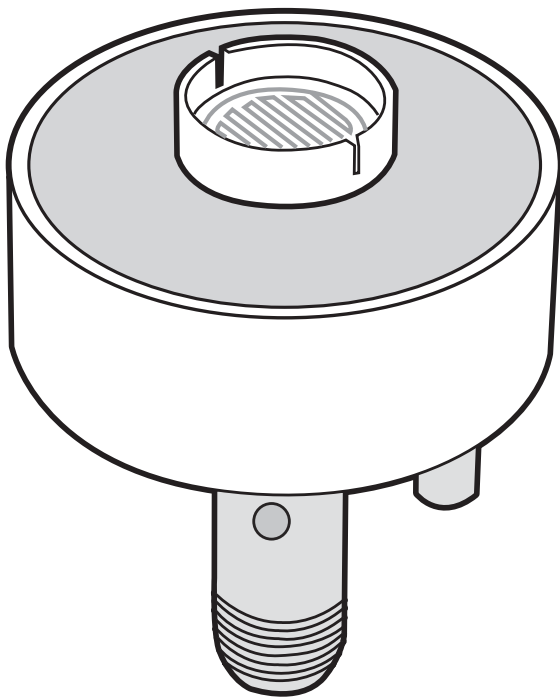

DESCRIPTION

The AIR-SS Snow Sensor detects falling or blowing snow at temperatures below 38°F (3.3°C). The AIR-SS provides the industry's most versatile and cost effective automatic snow detection when used with the SCP-120 Premium Snow Melting control.

Reliability and sensitivity are key AIR-SS features. The solid state design, combined with a rugged aluminum housing and epoxy potting, ensure years of trouble free service. Precision precipitation and temperature sensors assure snow detection accuracy.

Typical applications include controlling snow melting systems for sidewalks, driveways, doorways, stairs, loading docks, ramps for the physically challenged and parking garages. Low voltage operation, up to 2,000' (609.6m) separation from the control panel, mast or roof mounting, and noncritical extension wiring are just a few of the features making long distance control possible.

For complete information describing its application, installation and features, please contact Customer Service or check on the web at www.WarmlyYours.com.

Note: Sensor wire must remain separate from any high voltage wire to avoid a distorted sensor signal.

AIR-SS INSTALLATION

Choose an unobstructed, elevated location exposed to snowfall.

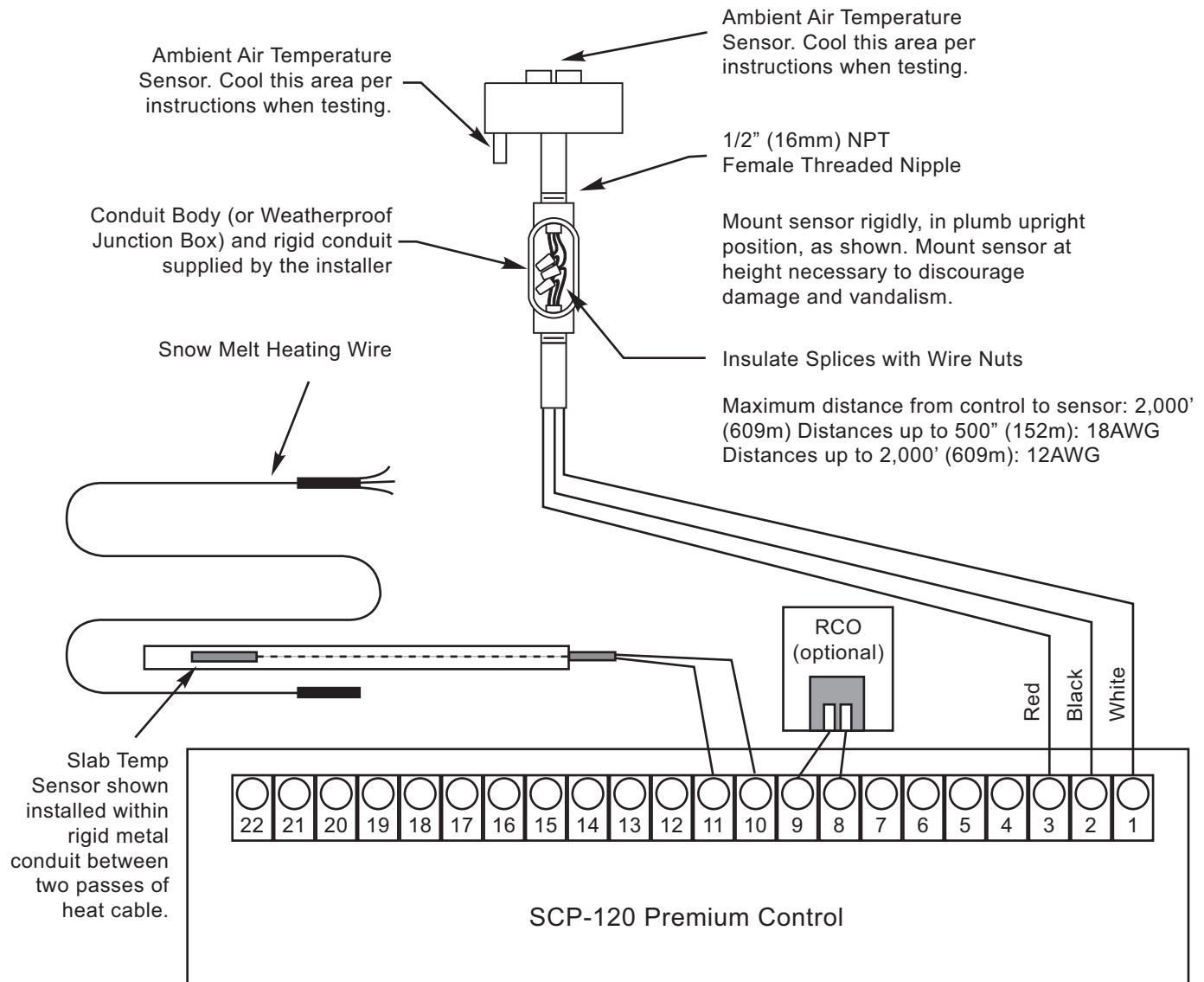

Note: All sensor and remote device connections are low voltage, Class 2 connections

ORDERING INFORMATION

ORDER NUMBER	DESCRIPTION	SNOW MELT CONTROL (NOT INCLUDED)
AIR-SS	AERIAL MOUNTED SNOW SENSOR	SCP-120 PREMIUM SNOW MELT CONTROL

LIMITED WARRANTY

WarmlyYours 2-year limited warranty covering defects in workmanship and materials applies. Contact your Account Manager for complete warranty information.

This document is the property of WarmlyYours. Subject to change without notice.

10214 6/09