

# SPECIFICATIONS

## Fiesta

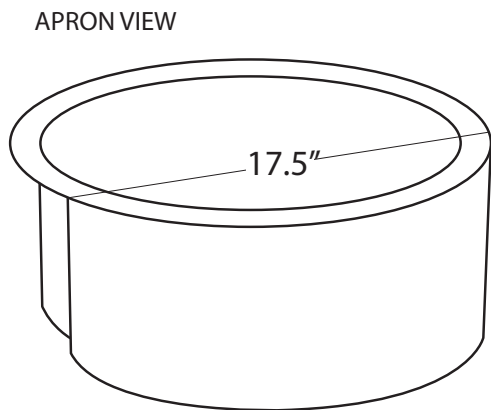
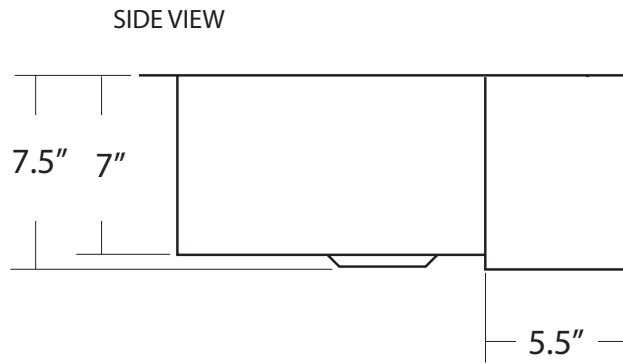
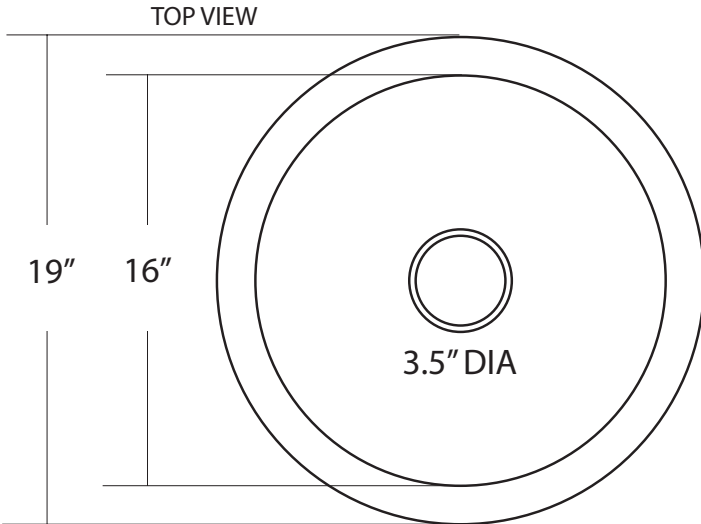

### FEATURES

- \* 19" x 7.5" OD
- \* 16" x 7" ID
- \* Hand hammered 16 gauge copper
- \* Apron extends 5.5" on sides
- \* 3.5" drain opening
- \* Dimensions are not exact and may vary 1/2"

### FINISHES

- \* Antique - CPS214
- \* Brushed Nickel - CPS514

### INSTALLATION

- \* Bar / Prep
- \* Undermount

### COORDINATING ACCESSORIES

- \* Drains: DR320 or DR340
- \* Bottom Grid: GR914

### STANDARDS COMPLIANCE

- \* IAPMO Listed

### IMPORTANT

Due to the handcrafted nature of this product, it will vary in finish, texture, hammering, and other details. Dimensions may vary up to 1/2". We strongly recommend that you wait for the actual product before making any installation cuts.