

SPECIFICATIONS

ZUMA

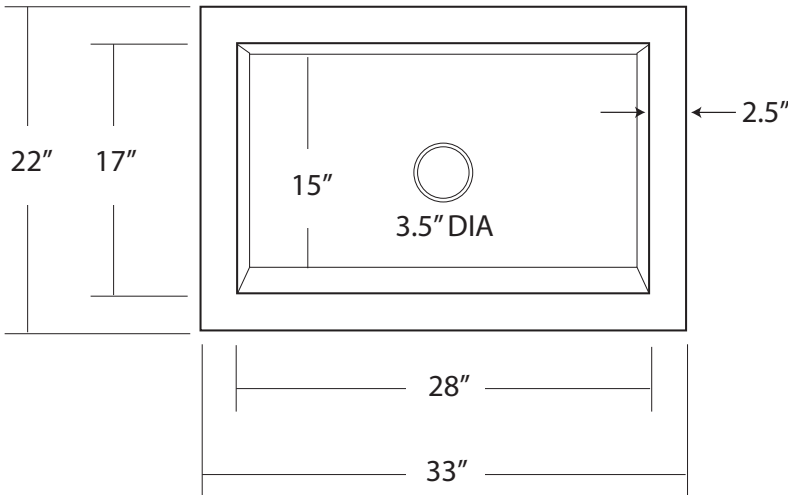

FEATURES

- * 33" x 22" x 10.5" OD
- * 28" x 17" x 10" ID
- * Hand hammered 16 gauge copper
- * Apron extends 4" on sides
- * 3.5" drain opening
- * Dimensions are not exact and may vary $\pm 1/2"$

FINISHES

- * Antique - CPS290
- * Brushed Nickel - CPS590

INSTALLATION

- * Kitchen
- * Undermount

COORDINATING ACCESSORIES

- * Drains: DR320 or DR340
- * Bottom Grid: GR971

STANDARDS COMPLIANCE

- * IAPMO Listed / cUPC

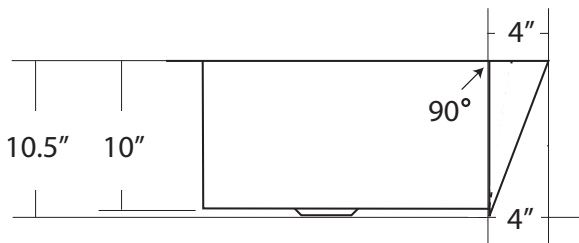

IMPORTANT

Due to the handcrafted nature of this product, it will vary in finish, texture, hammering, and other details. Dimensions may vary up to 1/2". We strongly recommend that you wait for the actual product before making any installation cuts.