

SPECIFICATIONS

Tatra

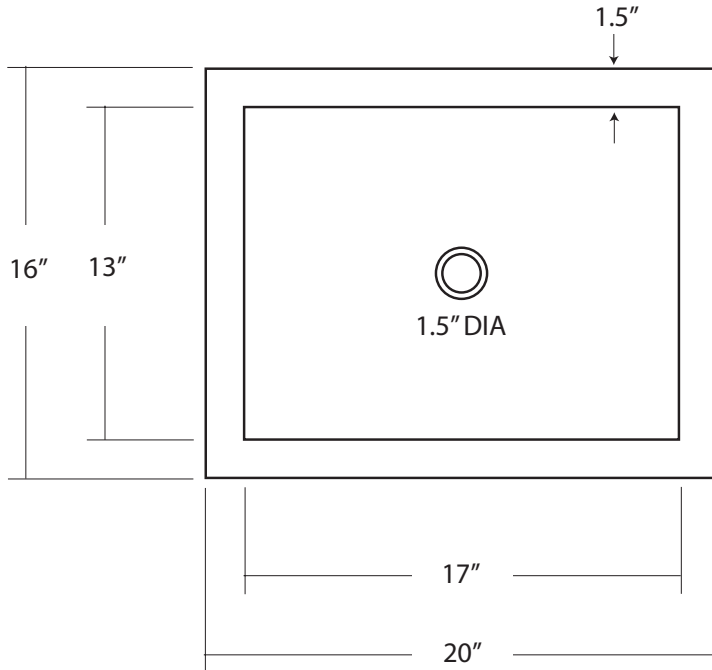

FEATURES

- * 16" x 20" x 4.5" OD
- * 13" x 17" x 4" ID
- * Hand hammered 16 gauge copper
- * 1.5" drain opening
- * Dimensions are not exact and may vary 1/2"

FINISHES

- * Antique - CPS246
- * Brushed Nickel - CPS546

INSTALLATION

- * Lavatory
- * Self-Rimming

COORDINATING ACCESSORIES

- * Drains: DR120, DR140 or DR160

STANDARDS COMPLIANCE

- * IAPMO Listed / cUPC

IMPORTANT

Due to the handcrafted nature of this product, it will vary in finish, texture, hammering, and other details. Dimensions may vary up to 1/2". We strongly recommend that you wait for the actual product before making any installation cuts.