

# SPECIFICATIONS

## 2" JR. STRAINER

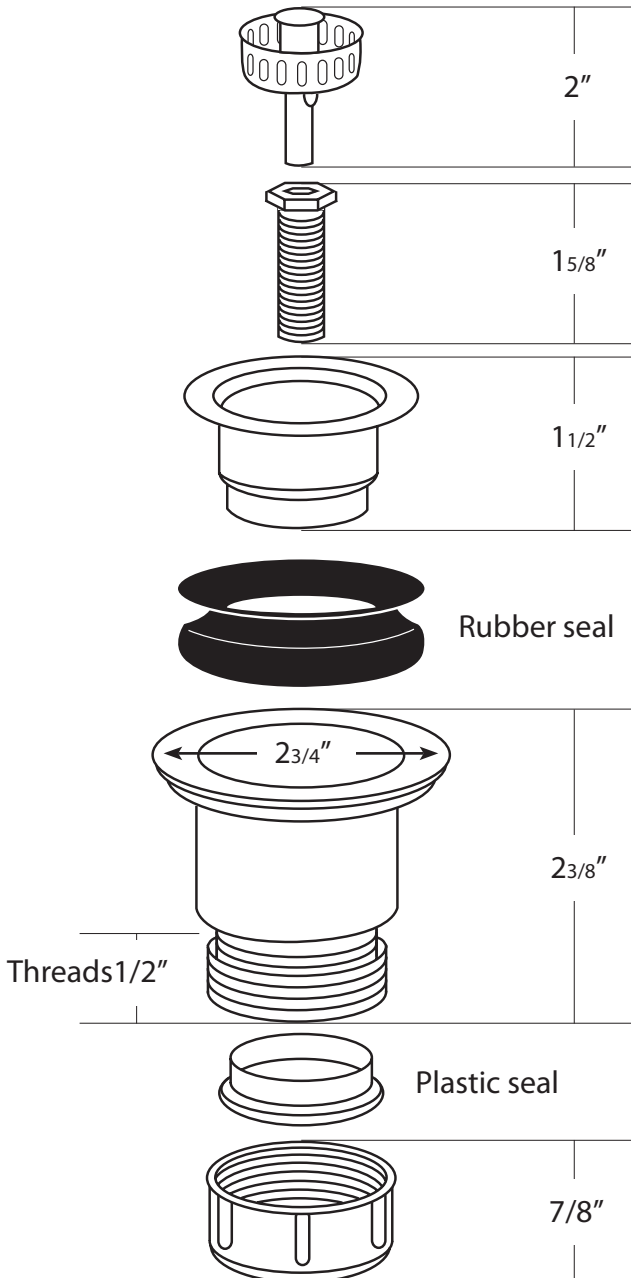

### FEATURES

- \* Fits 2" drain opening
- \* Features spring-loaded center post for a tight seal
- \* Overall length when assembled is 2 3/4"

### FINISHES

- \* DR220-BN (Brushed Nickel)
- \* DR220-ORB (Oil Rubbed Bronze)
- \* DR220-WC (Weathered Copper)

### USE WITH

- \* Bar & prep sinks with 2" drain opening (Diego, Small Square, etc.)