

# Installation Instructions

## ShadowBox Clarion Projection Screen by Draper

### Caution

- ① Read instructions through completely before proceeding.
  - ② Follow instructions carefully. Installation contrary to instructions invalidates warranty.
  - ③ Screen should be accessible for complete removal should fabric become damaged or should other service be required.
  - ④ Screen must be installed level (using a carpenter's level). All four sides of the screen should be the same distance from the wall.
  - ⑤ Wall surface behind screen should absorb, not reflect light.
  - ⑥ Nothing should be fastened to screen frame or viewing surface.
  - ⑦ Tools required: Medium (#2) Phillips Screwdriver, Carpenters Level, Measuring Tape, and Electric Drill with a No. 26 ( $\frac{9}{64}$ " ) Drill Bit.
  - ⑧ Open carton along the length, not at ends.
  - ⑨ Drill only through one side of the frame sections. Holes may need to be deburred.
  - ⑩ The ideal temperature range for assembling folding screens to prevent damaging the surface is 68°-78° F (20°-26° C). Assembling below recommended temperatures may damage surface and void warranty.
- NOTE:** Screen has been thoroughly inspected and tested at factory and found to be operating properly prior to shipment.

### Assembly of "Knocked Down" Screen

- ① Remove all pieces from the carton.
- ② Lay out the sections of the frame by matching up the numbers located on the back of the frame sections. Snaps should be facing up. Slide the ends of the castings from the top section into the side frame sections. Fasten these together using the  $\frac{1}{4}$ "-20 machine screws provided. Repeat this for the bottom section of the frame (see Fig. 1).

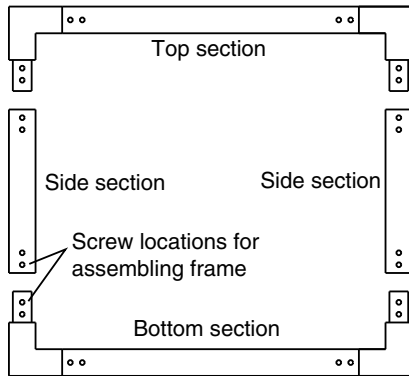

Back view of ShadowBox Clarion

Figure 1

- ③ Due to the unknown location of wall studs, or other supporting members, the mounting holes have not been predetermined. Determine the desired horizontal distance between the wall brackets. It is recommended that these brackets are not located within 6" of the outside frame sections or more than one quarter of the overall frame width in from the outside frame sections. Mark this horizontal distance on the top side of the top frame section and on the bottom side of the bottom frame section. Position the wall bracket so the inner edge of the bracket is approximately 1" from the back edge the frame (see Fig. 2). This will place the mounting hole in the center of the frame. Mark the frame through the holes and repeat for all other wall brackets. Centerpunch hole locations and drill through the frame wall using a No. 26 ( $\frac{9}{64}$ " ) drill bit.

**Please Note:** All mounting holes must be drilled the same distance from the back edge of the frame, to ensure that all four sides of the screen will be the same distance from the wall.

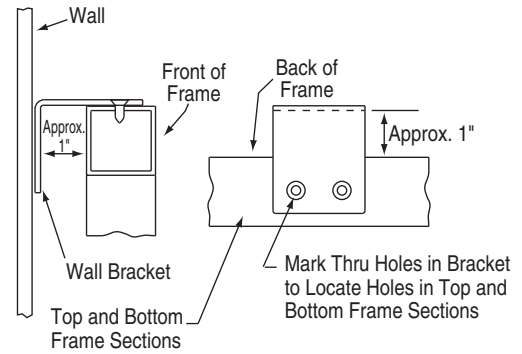

Side View

Top or Bottom View

Figure 2

**NOTE:** Only drill through one side of the frame sections. Holes may need to be deburred.

Attach wall brackets to the frame using the No. 10 sheet metal screws provided. Hold entire frame against the wall at desired location and mark location of wall brackets on the wall. Then remove all wall brackets from the frame and mount them on the wall. Installer must insure that fasteners are adequate strength and suitable for the mounting surface chosen (fasteners not provided).

- ④ Make sure your hands are clean before touching the viewing surface.
- ⑤ Remove the viewing surface from the cardboard tube. Unroll the surface from the small cardboard tube. **Caution**—be extremely careful to protect the viewing surface by making sure it is unrolled onto a clean cloth or paper.
- ⑥ Place the frame flat onto a clean surface with snaps facing up. Position the viewing surface gently on the frame with viewing side facing the snap side of the frame. Make sure that the top edge of the surface matches the top edge of the frame. Snap the two snaps at each corner first and then the remaining snaps.
- ⑦ Carefully position the screen between the wall brackets and fasten, using the No. 10 screws provided (see Fig. 3).

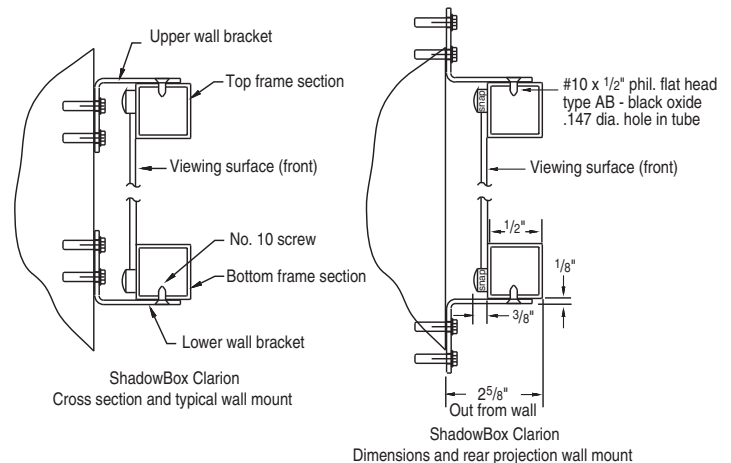

Figure 3

**Always fold viewing surface with snaps face-to-face. Do not permit screen fabric to contact border material or snaps when folded. Store in pouch provided.**

If you encounter any difficulties installing or servicing your ShadowBox Clarion Screen, contact your dealer or Draper, Inc., Spiceland, Ind., (765) 987-7999, or fax (765) 987-7142.

# DRAPER®

411 S. Pearl St., Spiceland, IN 47385 USA ■ 765-987-7999  
www.draperinc.com ■ fax 765-987-7142

Copyright © 2011 Draper Inc. Form ShadowBoxClarion\_Inst11 Printed in U.S.A.