

# Installation/Operating Instructions

## Silhouette/Series E & V Electric Projection Screen by Draper

US Patent Nos. 5,296,964; 6,111,694

### ⚠ Caution

- ① Read instructions through completely before proceeding; keep them for future reference. Follow instructions carefully. Installation contrary to instructions invalidates warranty. Care in mounting and correct operation will mean long and satisfactory service from your Draper screen.
  - ② Screen should be accessible for complete removal should fabric become damaged or should other service be required.
  - ③ Screen should be installed level (using a carpenter's level).
  - ④ Nothing should be fastened to screen dowel or viewing surface
  - ⑤ Operating switch(es) packed separately in screen carton. Do not discard with packing material.
  - ⑥ Screen operates on 110-120V, 60 hz., 1.1 amp current draw.
- NOTE:** Screen has been thoroughly inspected and tested at factory and found to be operating properly prior to shipment.

*These instructions are meant as a guide only. They do not imply any responsibility on the part of Draper, Inc. for improper installation or faulty workmanship at the jobsite.*

### Installation

Your Draper screen can be mounted on a wall or suspended from the ceiling, or mounted on 6" or 10"-14" extension brackets. *Extension brackets must be ordered separately from Draper.* With each method of installation, the case must be mounted level and with the flat back parallel to the wall.

To reduce the risk of personal injury, use only the hardware which comes with the screen or is specified in these instructions.

The screen (or wall extension brackets) should be mounted into studs or blocking in the wall/ceiling, or in drywall (minimum thickness 1/2") with specified anchors. For any other type of installation, follow all local building and safety codes.

Steel studs, concrete or cinder block walls and all other types of non-wood frame construction require the use of special screws or anchors. The selection of appropriate mounting hardware should be made by a qualified professional installer.

When locating viewing surface and checking clearance for screen's operation, remember surface is centered in case.

Take care to install wall/ceiling electrical box and conduit so they will be fully concealed by the screen case after installation.

Handle case carefully to avoid scratching.

Regardless of mounting method, screen should be positively and securely supported so that vibration or even abusive pulling on the viewing surface will not cause case to work loose or fall. Installer must insure that fasteners used are of adequate strength and suitable for the mounting surface chosen.

### Wall Mounting

Mount two, three or four aluminum brackets provided ("Z" Clips) on the wall at desired height, using appropriate fasteners. Verify that they are in line and level to fully engage with the mounting lip on back of screen case. 1 5/8" of free space is required above the "Z" Clips to allow case lip to be engaged over the lip of the "Z" Clips.

Engage the lip on back of screen case with lip of "Z" Clip and gently pull down to fully engage case to brackets.

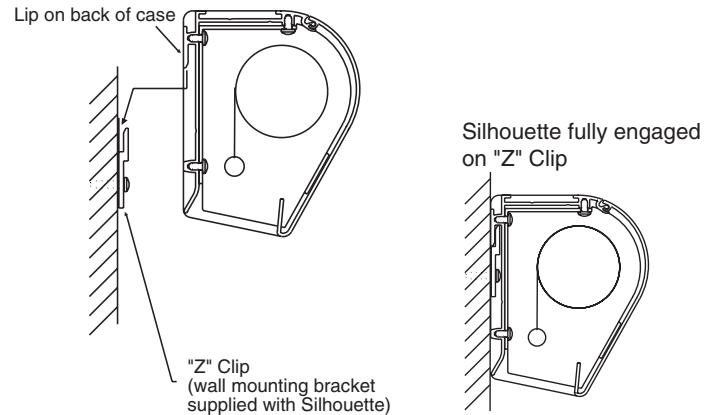

### Ceiling/Suspended Mounting

Locate two offset ceiling brackets (supplied) and slide these into the channel on top of screen case by aligning the chamfered edges of each bracket parallel to the channel length. Allow bracket to drop against bottom of channel and then rotate bracket counter-clockwise. Slide one bracket to each end of screen case until it stops against end cap of case. Tighten two set screws to lock bracket in place. Make sure that the flange of the ceiling bracket that has four holes is extended beyond the end caps of the case. Repeat above procedure for second ceiling bracket, making sure to slide it towards opposite end of case.

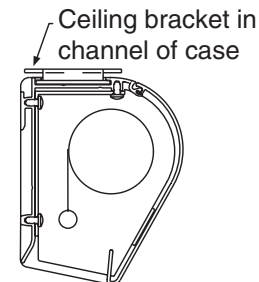

**To mount against ceiling,** hold screen case against ceiling and mark mounting hole locations. Each bracket has two holes towards the front edge and two holes towards the back edge. Installer must use at least two fasteners per bracket with one fastener in one of the two holes closest to back edge of bracket, and one fastener in one of the two hole closest to front edge of bracket. Installer must insure that fasteners are of adequate strength and suitable for the mounting surface chosen.

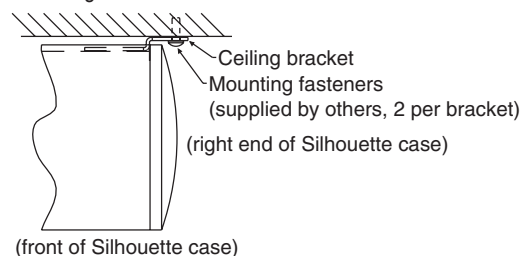

**To mount suspended from ceiling,** the brackets need to be installed on screen case as noted on page 1. Use "S" Hooks through the holes in the brackets to attach to ceiling. Select the set of holes that allows the screen to hang in a vertical position. The installer is to provide the "S" Hooks and the materials and fasteners to attach the "S" Hooks to the ceiling. Installer must insure that the fasteners and suspension material is of adequate strength and suitable for the mounting surface chosen.

# DRAPER®

411 S. Pearl St., Spiceland, IN 47385 USA ■ 765-987-7999  
 www.draperinc.com ■ fax 765-987-7142  
 Copyright © 2013 Draper Inc. Form SilhouetteE&V\_Inst13 Printed in U.S.A.

*If you encounter any difficulties installing or servicing your screen, call your dealer or Draper, Inc., Spiceland, Indiana, (765) 987-7999 or fax (765) 987-7142.*

## Extension Wall Brackets

6" or 10"-14" Extension Wall Brackets are needed to mount Silhouette extended from wall. Wall Brackets are not supplied with screen and must be ordered separately. Specify "Silhouette Extension Wall Brackets".

- ① Mount the Wall Brackets to the wall, making sure they are level and vertically plumb. Installer must insure fasteners (not included) are of adequate strength and suitable for chosen mounting surface.
- ② Attach hanging bracket to wall bracket as shown.
- ③ Attach (1) "Z" Clip and (1) Support Plate (supplied with screen) to hanging bracket as shown.
- ④ Engage the lip on back of screen case with lip of "Z" Clip and gently pull down to fully engage case to brackets.
- ⑤ Install hook bracket as shown making sure the two tabs of this bracket hook over the case extrusion.
- ⑥ Install #10-24 hex head screw through hook bracket, hanging bracket, and support plate as shown.

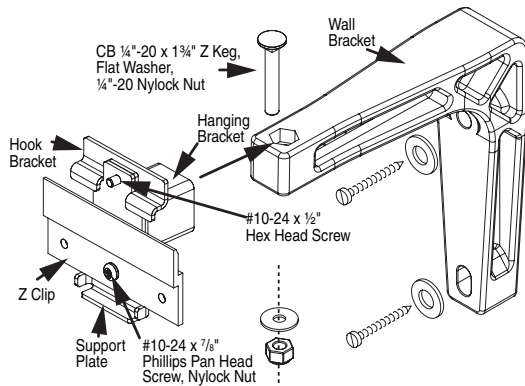

## Removing Case Fascia

**⚠ Caution:** When removing or reattaching fascia, do not handle fascia by unpainted ends.

Case fascia is removable to access roller assembly. To remove fascia, depress outward the spring lip located inside lower front corner of screen case and pull lower corner of fascia outward. Repeat this at right end of case. Support fascia from center and rotate lower front edge upward approximately 40° to disengage the Roll-Lok hinge at the top front of screen case. Fascia can now be completely removed from case.

To install fascia, generally reverse instructions above making sure the Roll-Lok hinge is completely engaged before rotating fascia down towards the closed position. Depress spring clips outward, push lower corners of fascia inward until lips of spring clips hook behind fascia.

**Please Note:** Be sure the clips are completely up against the ends of the fascia.

## Electrical Connections

Screen operates on 110-120V, 60 Hz., 1.1 amp current draw.

Junction box is located at left end of screen. It is accessible through front of screen case after fascia is removed (see instructions above for removing fascia).

Electrical supply wires can enter through the back or top of case. For top entry, remove plug from top conduit hole and snap plug into hole on back side of case.

Junction box contains red, black, and white pigtail leads and green internal ground wire per wiring diagram attached.

If optional low voltage control or video interface control is specified, please refer to wiring diagrams on pages 4-5.

Wall or ceiling electrical box should be installed so as to be fully concealed by screen case after installation.

Screen is shipped with internal wiring complete and control switch(es) fully boxed. Wire to connect screen to switch(es) and switch(es) to power supply should be furnished by installer. Please Note: Screen must be installed in accordance with the requirements of the Local Building Codes, the Canadian Electrical Code (CEC), CAN/CSA C22.1 and the National Electric Code (NEC), NFPA 70. An appropriate disconnect device shall be provided as part

of the building installation.

**All operating switches should be "off" before power is connected.**

Plug-in power cord option available on units with built-in low voltage controller.

**For Reconfiguration/Conversion of Non-detachable Power Cord to Field Wiring for Models SLE-28, SLE-30, SLV-28 and SLV-30 Only:**

- ① Disconnect cord plug from outlet.
- ② Remove junction box cover.
- ③ Disconnect wire nut connections from black, white and green wires.
- ④ Remove power cord and strain relief.
- ⑤ Connect the black from motor to "hot" supply wire.
- ⑥ Connect white wire from motor to "neutral" supply wire.
- ⑦ Connect green/yellow ground to "ground" supply wire.
- ⑧ Replace junction box cover.

## Operation

Before operating screen, remove any shipping brackets or tape securing fabric and dowel to the roller. If viewing surface hangs out of case 8" or 9", tape has probably been broken by rough handling in shipment, allowing surface to "unwrap" one turn off the roller. Manually wrap fabric back around the roller without turning the roller itself.

When screen is first operated, **be cautious!** Cycle unit down and up several times to confirm satisfactory operation.

**110-120V SINGLE STATION CONTROL**—3-position UP-OFF-DOWN switch permits operation to be stopped at any point. Factory adjusted limit switches automatically stop screen when fully down or fully up.

**110-120V MULTIPLE STATION CONTROL**—Switches are similar in appearance to 110-120V Single Station Control. Screen stops when switch is released and may be restarted in either direction. Factory adjusted limit switches stop screen automatically when fully down or fully up.

**24V MULTIPLE STATION CONTROL**—Three-button UP-STOP-DOWN switches stop at any point desired, operate in any sequence. Factory adjusted limit switches automatically stop screen when fully down or fully up.

**110-120V & 12V VIDEO INTERFACE CONTROL**—Allows screen to be controlled by a trigger signal—when the signal comes on, the screen descends automatically. Two versions: Model VIC115 integrates screen operation with a DRAPER video projector lift or a video projector or tuner with a 110-120V switch outlet. Model VIC12 interfaces with a 12V switch outlet. Both available with an override switch (VIC-OS), permitting independent operation. VIC-OS not available with factory installed VIC115 & VIC12.

**KEY OPERATED SWITCHING**—Two kinds of key-operated switches are optionally available with this unit.

- ① The key-operated power supply switch controls power to the screen and switches. When it is "off", the switches will not operate screen. Key may be removed from the switch in either "on" or "off" position.
- ② A three-position key switch permits the screen to be operated directly by key. In this case, the screen's operator must always have a key.

**RS232/ETHERNET**—Serial communication and network communication optionally available with wall switches, RF or IR remote.

**PLUG & PLAY™**—Provided with handheld IR remote control transmitter and 10' (3m) cord. No wiring necessary except to connect to RS232. Screen is equipped with a handheld remote or 3-position operating switch (see below). Three positions (up-off-down) permit operation to be stopped at any point. Factory adjusted limit switches automatically stop screen when fully down or fully up.

## Limit Adjustments—Standard Motor

**Please Note:** Screen limits are factory set for optimum performance of the screen. Any adjustment of these limits could void the warranty. Please check with Draper prior to resetting screen limits.

**⚠ CAUTION:** Always be prepared to shut screen off manually when new adjustment is being tested. Screen may be severely damaged if viewing surface is allowed to run too far up or too far down.

**⚠ CAUTION:** Be sure all switches are in "off" position before adjusting limit switches.

The motor limit screws are normally located on the audience left of screen roller.

## "DOWN" LIMIT ADJUSTMENT

### To Reduce Screen Drop

- ① Raise screen surface about 1' above desired setting and turn off.
- ② Turn the WHITE/DOWN limit screw clockwise (three screw turns = ½ roller revolution).
- ③ Test by running screen down and repeat steps 1 and 2 until desired position is reached.

### To Increase Screen Drop

- ① Run screen to the down limit.
- ② With the down switch on, turn the WHITE/DOWN limit screw counterclockwise (three turns of screw = ½ roller revolution) to increase drop.
- ③ Test by running screen up about 1' and back down to new down limit.
- ④ Repeat steps 2 and 3 until desired position is reached.

## "UP" LIMIT ADJUSTMENT

### Screen is Running Too Far Up

- ① Lower screen surface about 1' below desired setting and turn off.
- ② Turn the YELLOW/UP limit screw clockwise (three screw turns = ½ roller revolution).
- ③ Test by running screen up.
- ④ Repeat steps 1 through 3 until desired position is reached.

### Screen Needs to Run Up More

- ① Run screen down about 1' and turn off.
- ② With the up switch on, turn the YELLOW/UP limit screw counterclockwise (three turns of screw = ½ roller revolution).
- ③ Repeat steps 1 and 2 until desired position is reached.

**CAUTION: Do NOT allow the dowel to wrap up over the roller when the screen is running up! This could damage the screen.**

## Limit Adjustments (Built-in Low Voltage Motors)

**Please Note: Screen limits are factory set for optimum performance of the screen. Any adjustment of these limits could void the warranty. Please check with Draper prior to resetting screen limits.**

**⚠ CAUTION: Always be prepared to shut screen off manually when new adjustment is being tested. Screen may be severely damaged if viewing surface is allowed to run too far up or too far down.**

**⚠ CAUTION: Be sure all switches are in "off" position before adjusting limit switches. (Height adjustments are made from wall switch)**

- ① Connect the ILT switch to the motor via the terminal blocks, or via the modular port using four conductor modular cable. When using modular cable, the cable connectors MUST NOT be crimped in reverse, as with standard telephone cable.
  - ② Set the slide switch to the lower position. Press and hold the DOWN button on the switch to move the viewing surface to the desired lower limit. If the screen moves in the opposite direction, release the DOWN button and press and hold down the STOP button for four seconds. This will reverse the operation of the UP and DOWN switches.
  - ③ Move slider switch into center position. Wait a couple of seconds.
- Please Note: If you move the slider switch from down to up in one motion it sets the two limits in the same position.**
- ④ Set the slide switch to the higher position. Move the viewing surface to the desired upper limit by pressing and holding the UP button on the wall switch.
  - ⑤ Return the slide switch to the center position to return to normal operation.
  - ⑥ To set the viewing surface to an alternate format position, move the viewing surface to the desired position and press the STOP button. Press and hold the STOP button for at least three seconds to record the position.

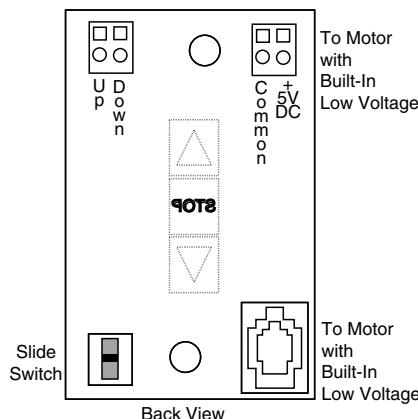

**Please Note: 5V DC must be connected to be able to set limits using the wall switch.**

POSITION	FUNCTION
DOWN	Set LOWER limit
UP	Set UPPER limit
CENTER	Normal Operation

**Please Note: Pressing and releasing the UP button on the switch will move the screen to its upper limit. Pressing and releasing the DOWN button will move the screen to its lower limit.**

**While the motor is in motion, pressing the STOP button for less than two seconds will stop the viewing surface at its present position.**

**Once the motor is stopped, pressing the STOP button will move the viewing surface to its alternate format position.**

**Pressing and holding the STOP button, when the motor is at rest or in motion, for at least three seconds will record a new alternate format position.**

**⚠ Caution: Do not remove the roller assembly from the case unless necessary for repairs. If the roller assembly is removed, be sure motor is fully re-seated in the bracket, and re-secure it carefully with the motor retaining spring (see diagram at right).**

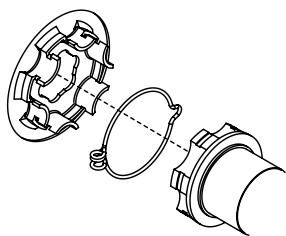

## Tab-Tension Adjustment Procedure for Silhouette/Series V

- ① Determine which side requires adjustment.
- ② Secure dowel with one hand.
- ③ **⚠ Caution: Do not touch or bend surface.** Using Phillips-head screwdriver, depress spring-loaded adjustment screw (see drawing) and slowly turn clockwise to tighten tension, or counterclockwise to loosen tension. The screw adjusts in ¼ turn increments. Adjust only **one increment** (¼ turn).
- ④ If problem is not corrected, leave screen in position for 24 hours to allow surface material to stretch into position.
- ⑤ If problem still is not corrected, repeat steps 2 and 3.

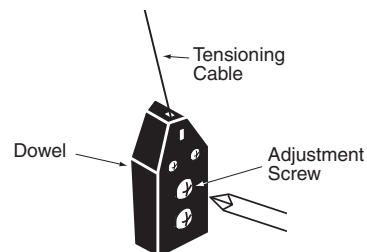

## Case Dimensions

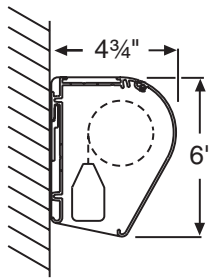

Silhouette	D
Series E	6"
Series V	Varies

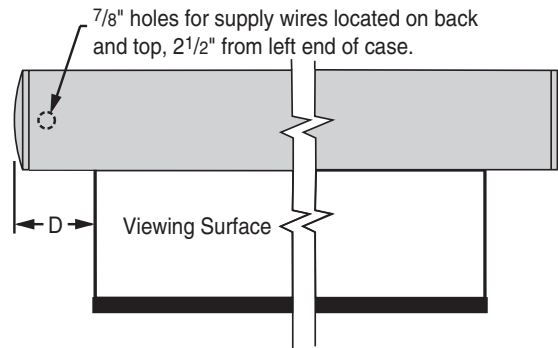

Series E Viewing Surface Shown; Series V with Tab Tensioning also available. At left, Series V slat bar is depicted inside case. Series E has a typical round bottom dowel. For all Silhouettes, the dowel is concealed inside the case.

## Wiring Diagrams

Please Note: Do not wire motors in parallel.

### Wiring Diagrams—110-120V Motor and Quiet Motor

#### Single Station Control

#### Multiple Station Control

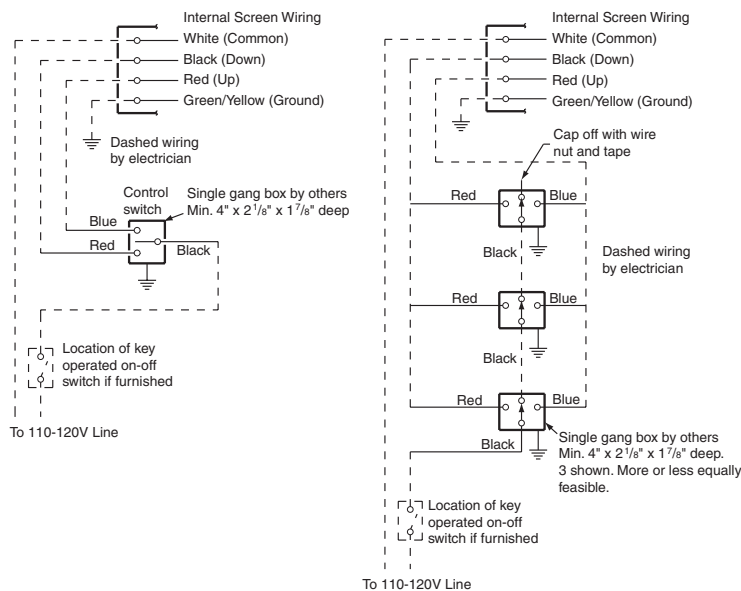

### Wiring Diagrams—110-120V Motor and Quiet Motor with Built-in Low Voltage Controller

#### Single Low Voltage Control

#### Multiple Low Voltage Controls

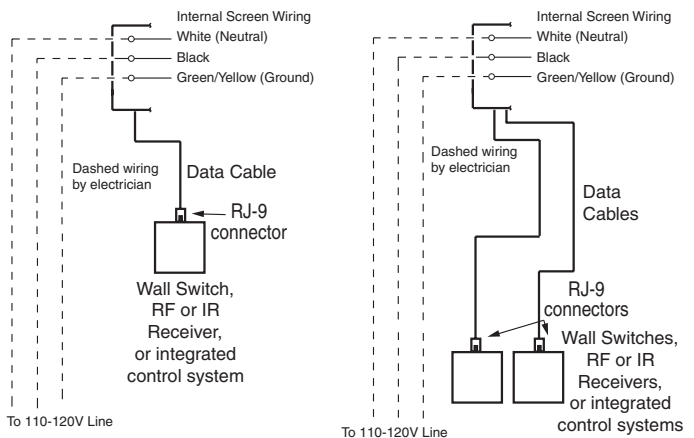

### Wiring Diagrams—Plug & Play 110-120V Motor with Built-in Low Voltage Controller

#### Single Low Voltage Control

#### Multiple Low Voltage Controls

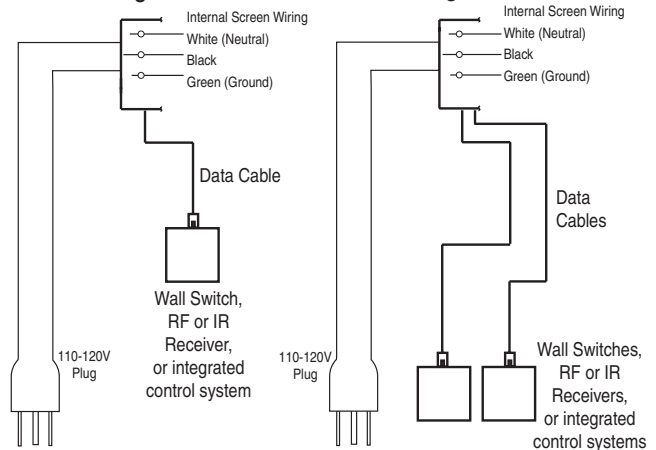

### ILT Switch-to-Motor—

#### Dry Contacts or Data Cable connection

Back of wall switch.

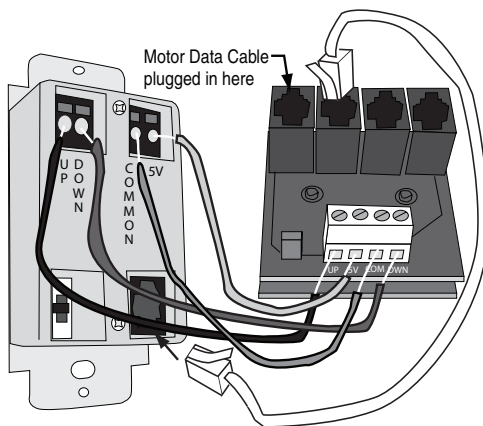

Please Note: This Splitter/Jack is located inside the junction box of your screen.

Data Cables to switches or to additional motors can be plugged into any of the three open jacks. If this is a "Case First, Screen Later" installation, plug the motor cable into the jack indicated in the drawing.

Please Note: 5V DC must be connected to be able to set limits using the wall switch.

Please Note: Although both Dry Contact and Data Cable connections are shown, you should only use one connection type per motor.

## External Low Voltage & Wireless Control

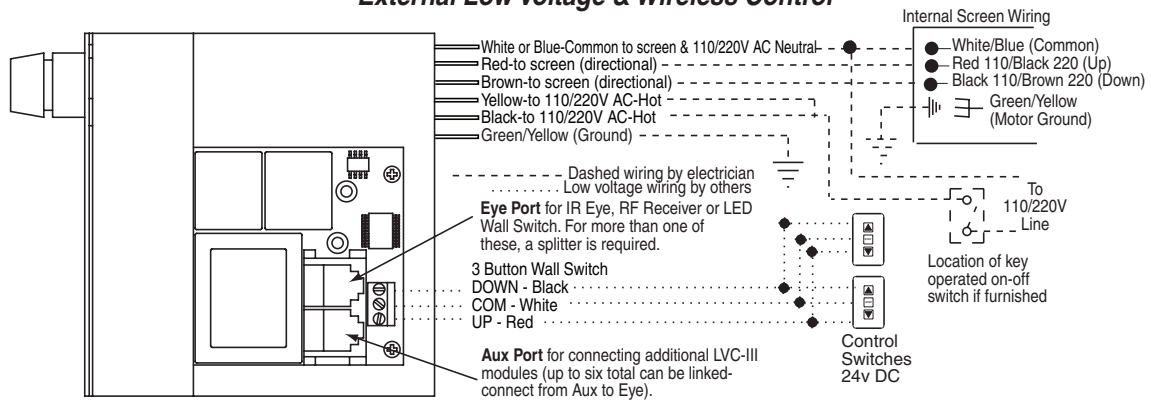

## External Two-Way Serial Communication (RS232) with MC1

See separate Serial Communication-RS232 Instruction sheet for enabling RS232 with the MC1.

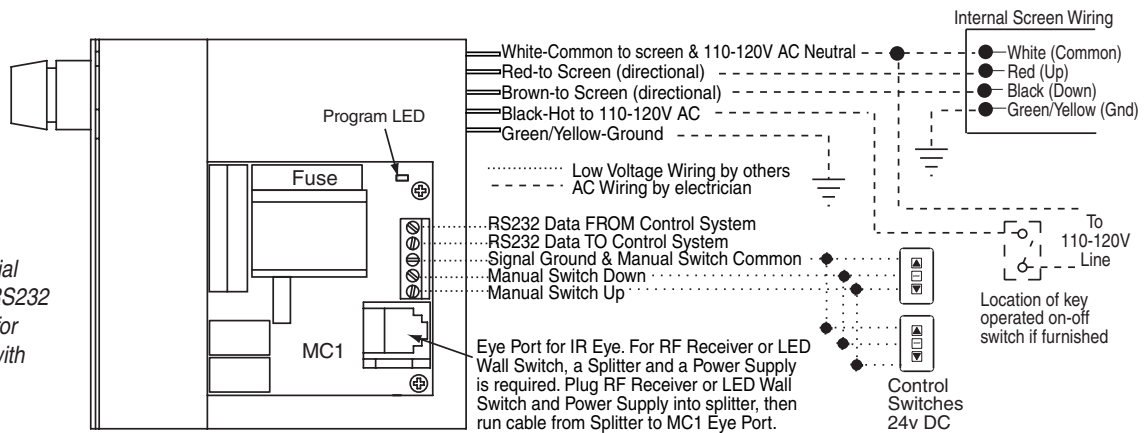

## Wiring Diagrams for Optional, Built-in Video Interface Control

### Built-in Video Interface Control

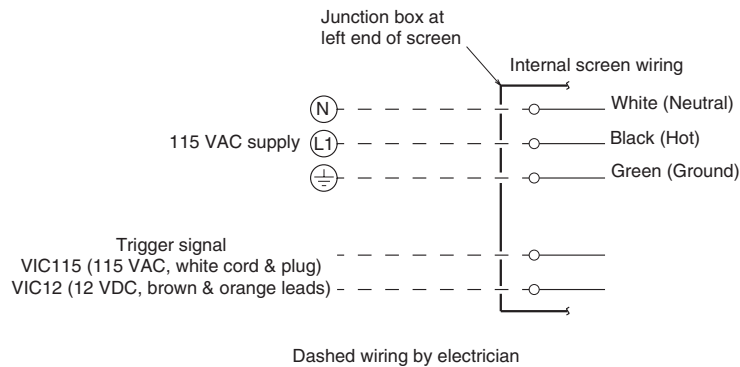

### Built-in Low Voltage Control

