

Installation/Operating Instructions

220V Envoy Electric Projection Screen by Draper

These Installation/Operating Instructions are available in the official language of the country where you purchase the product. Please contact your distributor to request a copy.

Vous pourriez demander les instructions d'installation et d'opération traduites dans la langue officielle du pays où vous achetez le produit. Veuillez demander à votre distributeur.

Die Gebrauchsanweisung für Installation und Konstruktion sind in der offiziellen Sprache des Landes, indem Sie das Produkt gekauft haben, vorhanden. Fragen Sie die jeweilige Verkaufs-Abteilung.

Caution

- 1 Read instructions through completely before proceeding.
- 2 Follow instructions carefully. Installation contrary to instructions invalidates warranty.
- 3 Do not lift case in center. Lift the ends simultaneously to avoid damage to case and surface.
- 4 Entire bottom of screen case should be unobstructed to permit proper operation of automatic trap door, and access to bottom panel for making electrical connections or servicing.
- 5 Screen should be installed level (using a carpenter's level).
- 6 Nothing should be fastened to screen dowel, viewing surface or automatic trap door.
- 7 Operating switch(es) packed separately in screen carton. Do not discard with packing material.
- 8 Screen operates on 220V AC, 50 Hz., 1 ph. current.

NOTE: Screen has been thoroughly inspected and tested at factory and found to be operating properly prior to shipment.

These instructions are meant as a guide only. They do not imply any responsibility on the part of the manufacturer for improper installation or faulty workmanship at the jobsite.

Hanging Screen

General:

When locating viewing surface and checking clearance for screen's operation, remember surface is centered in case. Screen is normally recessed above ceiling and may be installed in a variety of ways. See typical installation detailed on back of this sheet. Regardless of mounting method used, the following points apply:

- 1 Screen should be lifted into position **only by the mounting brackets. Keep case level by lifting both ends simultaneously to prevent surface damage. Never attempt to lift screen along its length.**
- 2 Screen should be positively and securely supported so that vibration or even abusive pulling on viewing surface will not weaken installation.
- 3 Installer must insure that fasteners used are of adequate strength and suitable for the mounting surface chosen.
- 4 Entire bottom of case must be readily accessible after installation is complete.
- 5 Hinge on bottom board and particularly hinge on automatic trap door of screen must be permitted to operate freely. Front and back of case must be straight—not forced to warp or bow. Hinges must be free from mastic or paint buildup, and doors must be unobstructed by ceiling tiles.
- 6 Do not use screen case to support adjacent sections of ceiling.
- 7 If trim pieces must be attached to case, do not permit screws to protrude through 19 mm (¾") wall of case. Do not attach trim with nails.
- 8 If case is painted, slots around doors should be shielded to protect viewing surface from paint splatters or overspray.
- 9 Do not seal unit in ceiling until electrical connections have been made and screen has been operated successfully.

Electrical Connections

Screen operates on 220V AC, 50 Hz., 1 ph. current.

Junction box is located just above bottom board near left end of screen. Bottom board is held closed with flathead screws and may be opened with a Phillips screwdriver/Allen wrench (4mm or 5/32"). Automatic trap door is held shut by viewing surface and must not be forced open. Junction box contains brown, black and blue pigtail leads and green internal ground wire, per wiring diagram on reverse.

Screen is shipped with internal wiring complete and control switch(es) fully boxed. Wire connecting screen to switch(es) and switch(es) to power supply should be furnished by installer. Connections should be made in accordance with attached wiring diagram, and wiring should comply with National and local electrical codes.

All operating switches should be "off" before power is connected.

Operation

When screen is first operated, be cautious! If automatic trap door does not drop open immediately when switch is flipped "down", return switch to "off" and free trap door and/or recheck electrical connections before proceeding. Cycle unit down and up several times to confirm satisfactory operation.

220V Single Station Control—3-position up-off-down switch permits operation to be stopped at any point. Factory adjusted limit switches automatically stop screen when fully down or fully up.

220V Multiple Station Control (Not CE approved)—Switches are similar in appearance to 220V Single Station Control. Screen stops when switch is released and may be restarted in either direction. Factory adjusted limit switches stop screen automatically when fully down or fully up.

24V Control—Three-button up-stop-down switches stop at any point desired, operate in any sequence. Factory adjusted limit switches automatically stop screen when fully down or fully up. Installer should incorporate an all-pole disconnect in the fixed wiring.

Key Operated Switching (Not CE approved)—Two kinds of key-operated switches are optionally available with this unit. ① The key-operated power supply switch controls power to the screen and switches. When it is "off", the switches will not operate screen. Key may be removed from the switch in either "on" or "off" position. ② A three-position key switch permits the screen to be operated directly by key. In this case, the screen's operator must always have a key.

RS232/Ethernet—Serial communication and network communication optionally available with wall switches, RF or IR remote.

Adjustments

Please Note: Screen limits are factory set for optimum performance of the screen. A procedure is outlined below for minor tweaks, but any adjustment of these limits may negatively affect the flatness of the screen surface and could also void the warranty. Please check with Draper prior to resetting screen limits.

CAUTION: Always be prepared to shut screen off manually when new adjustment is being tested. Screen may be severely damaged if viewing surface is allowed to run too far up or too far down.

CAUTION: Be sure all switches are in "off" position before adjusting limit switches.

Adjusting "fully up" position — "Up" limit switch, located immediately above left end of automatic trap door, is tripped as door closes. If door does not close fully, limit switch should be raised slightly. If door closes too tightly, switch should be lowered slightly.

Remove steel plate attached to threaded neck of "up" limit switch by removing hex nut securing it. Removing plate exposes three Phillips head machine screws which hold limit switch bracket in place. Turning these screws clockwise will raise limit switch; turning them counterclockwise will lower it. Raise switch only in quarter-turn increments. When operating properly automatic trap door should close gently and rest against but not press on rubber bumpers above it. Adjusting automatic door so that it closes too tightly will damage screen.

Adjusting "fully down" position — "Down" stopping position may be adjusted by turning the white limit switch adjustment socket. The white socket is located on the left end of screen roller and is accessible to a screwdriver/Allen wrench (4mm or 5/32") when automatic trap door is open. Access is easier when bottom board is also open. (Do not adjust the yellow socket which is next to and in back of the white socket). Turning the white socket counterclockwise will allow the viewing surface to run farther down. Turning it clockwise will shorten the viewing surface, causing it to stop in a less extended position. At no time should viewing surface be unrolled enough to expose any part of screen roller.

DRAPER®

411 S. Pearl St., Spiceland, IN 47385 USA ■ +1 765-987-795

www.draperinc.com ■ fax +1 765-987-1689

Copyright © 2013 Draper Inc.

Form Envoy220v_Inst13

Printed in U.S.A.

If you encounter any difficulties installing or servicing your Envoy screen, call your dealer or Draper, Inc. Spiceland, Indiana, USA, 765/987-7999 or fax 765/987-1689.

Case Dimensions and Wiring Diagrams

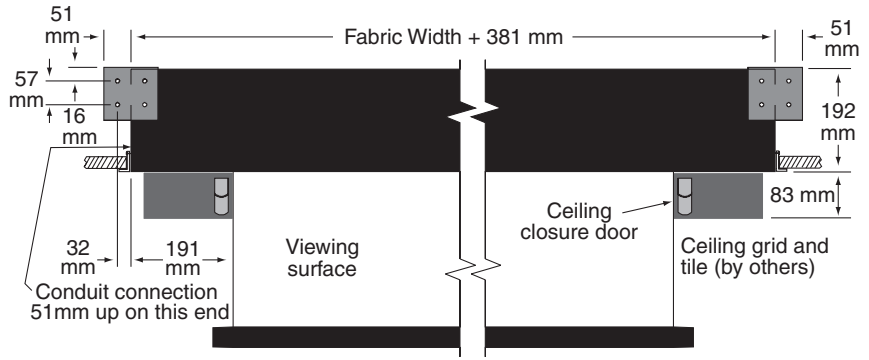
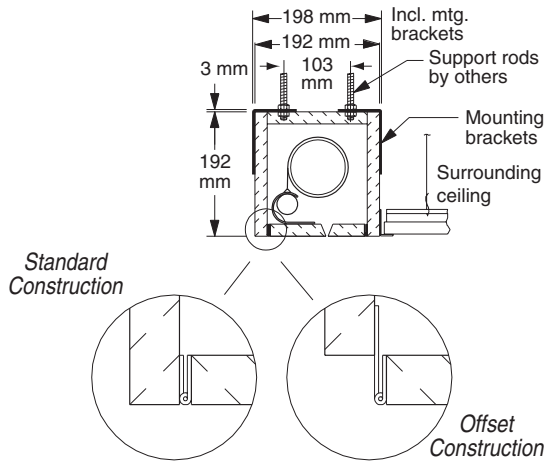

Please Note: Do not wire motors in parallel.

Limit Adjustments (Built-in Low Voltage Motors)

Please Note: Screen limits are factory set for optimum performance of the screen. A procedure is outlined below for minor tweaks, but any adjustment of these limits may negatively affect the flatness of the screen surface and could also void the warranty. Please check with Draper prior to resetting screen limits.

CAUTION: Always be prepared to shut screen off manually when new adjustment is being tested. Screen may be severely damaged if viewing surface is allowed to run too far up or too far down.

- Connect the ILT switch to the motor via the terminal blocks, or via the modular port using four conductor modular cable. When using modular cable, the cable connectors MUST NOT be crimped in reverse, as with standard telephone cable. (For a Dry Contacts Wiring diagram, see page 3.)
- Set the slide switch to the lower position. Press and hold the DOWN button on the switch to move the viewing surface to the desired lower limit. If the screen moves in the opposite direction, release the DOWN button and press and hold down the STOP button for four seconds. This will reverse the operation of the UP and DOWN switches.
- Move slider switch into center position. Wait a couple of seconds.

Please Note: If you move the slider switch from down to up in one motion it sets the two limits in the same position.

- Set the slide switch to the higher position. Move the viewing surface to the desired upper limit by pressing and holding the UP button on the wall switch.
- Return the slide switch to the center position to return to normal operation.
- To set the viewing surface to an alternate format position, move the viewing surface to the desired position and press the STOP button. Press and hold STOP button for at least 3 seconds to record position.

Please Note: Pressing and releasing the UP button on the switch will move the screen to its upper limit. Pressing and releasing the DOWN button will move the screen to its lower limit.

While the motor is in motion, pressing the STOP button for less than two seconds will stop the viewing surface at its present position.

Once the motor is stopped, pressing the STOP button will move the viewing surface to its alternate format position.

Pressing and holding the STOP button, when the motor is at rest or in motion, for at least three seconds will record a new alternate format position.

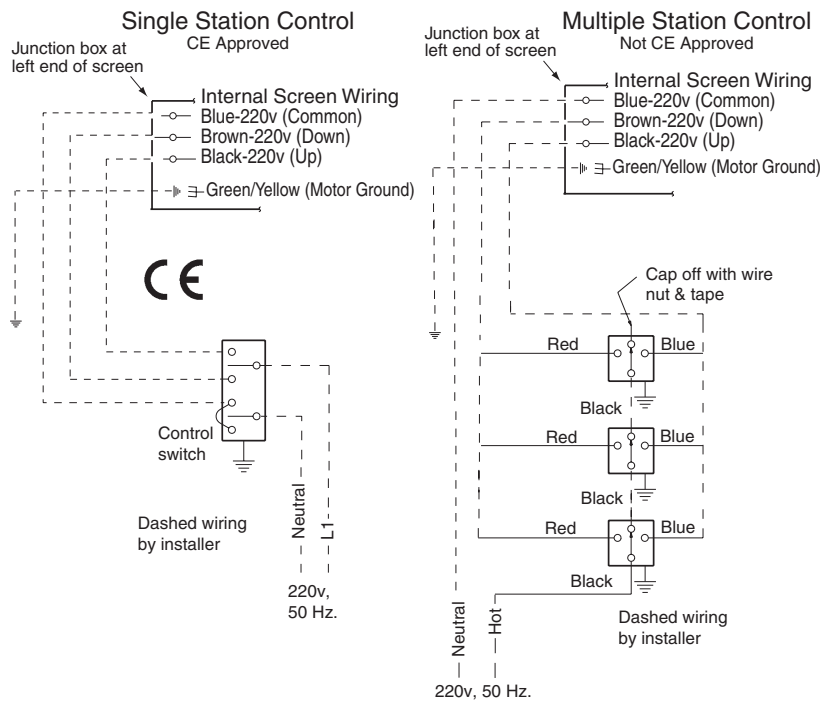

Wiring Diagrams—220V Motor and Quiet Motor with Built-in Low Voltage Controller

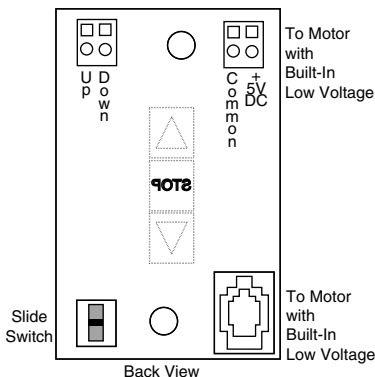
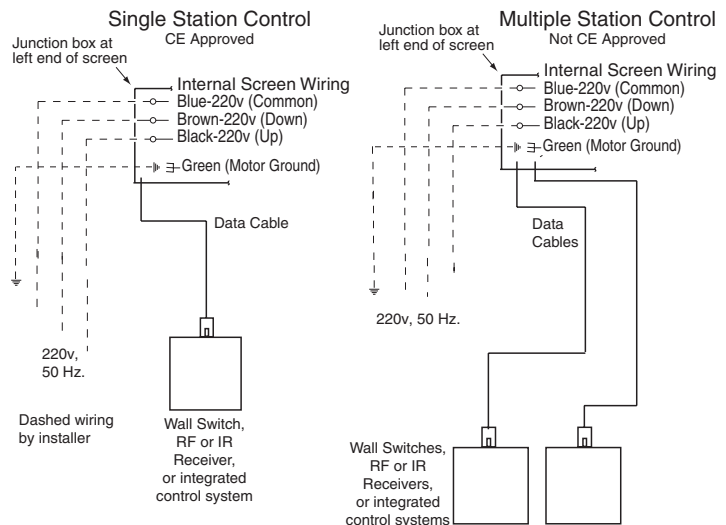

POSITION	FUNCTION
DOWN	Set LOWER limit
UP	Set UPPER limit
CENTER	Normal Operation

ILT Switch-to-Motor—Dry Contacts or Data Cable connection

Back of wall switch.

Please Note: Although both Dry Contact and Data Cable connections are shown, you should only use one connection type per motor.

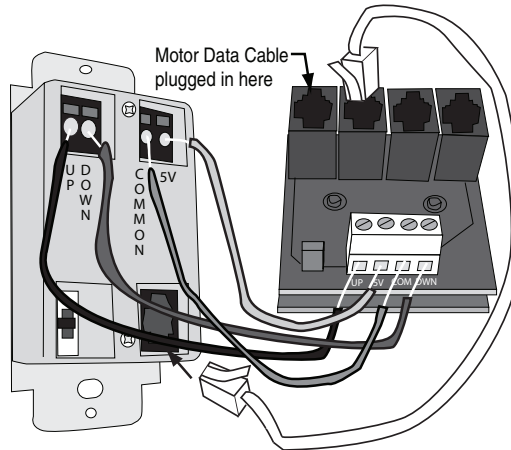

Please Note: This Splitter/Jack is located inside the junction box of your screen.

Data Cables to switches or to additional motors can be plugged into any of the three open jacks. If this is a "Case First, Screen Later" installation, plug the motor cable into the jack indicated in the drawing.

External Low Voltage & Wireless Control

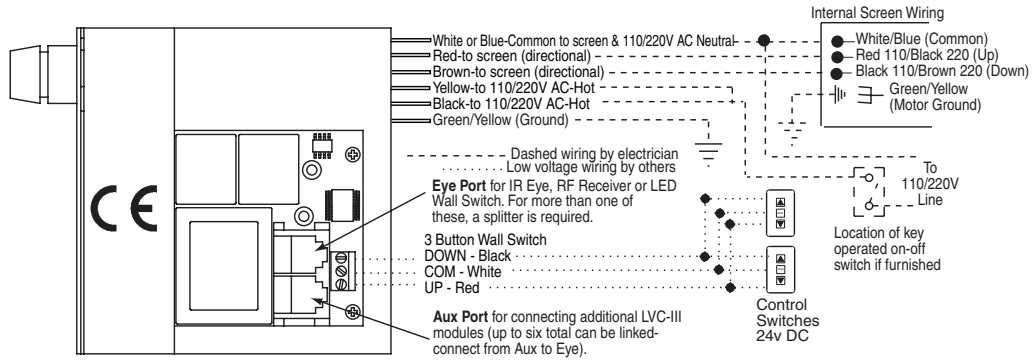

Two-Way Serial Communication (RS232) with MC1

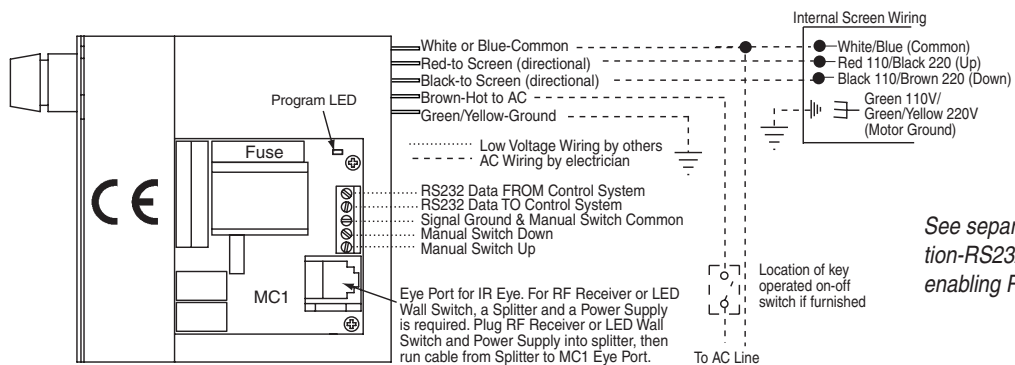

See separate Serial Communication-RS232 Instruction sheet for enabling RS232 with the MC1.