

Installation Instructions

Premier Electric Projection Screen by Draper

⚠ Caution

- ① Read instructions through completely before proceeding.
- ② Follow instructions carefully. Installation contrary to instructions invalidates warranty.
- ③ Screen should be accessible for complete removal should fabric become damaged or should other service be required.
- ④ Screen should be installed level (using a carpenter's level).
- ⑤ Nothing should be fastened to screen dowel or viewing surface.
- ⑥ Operating switch(es) packed separately in screen carton. Do not discard with packing material.
- ⑦ Screen operates on 110-120V, 60 Hz., 1.1 amp current draw.

NOTE: Screen has been thoroughly inspected and tested at factory and found to be operating properly prior to shipment.

These instructions are meant as a guide only. They do not imply any responsibility on the part of the manufacturer for improper installation or faulty workmanship at the jobsite.

Hanging Screen

General:

When locating viewing surface and checking clearance for screen's operation, remember surface is centered in case. Handle case carefully to protect finish. Regardless of mounting method, screen should be positively and securely supported so that vibration or even abusive pulling on the viewing surface will not cause case to work loose or fall. Installer must insure that fasteners used are of adequate strength and suitable for the mounting surface chosen.

Suspended Installation:

Suspend screens from holes in endcaps as shown. "S" hooks, chains (or cable) and turnbuckles should be provided by installer. "S" hooks should go through the rear holes on the endcap sides (see drawing on page 2), and both ends of the "S" hooks should be crimped for additional safety. Chains should be attached to beams or other structural members. Turnbuckles should be adjusted so screen hangs level.

Wall Installation:

Mount screen through holes in back of endcaps as shown. Installer should furnish screws, toggle bolts, molly bolts, nylon or lead anchors as required.

Wall or Ceiling Installation with Floating Brackets:

Floating brackets should be located on studs or joists. The bracket then attaches at any almost any point along the case. For details, see separate instruction sheet that ships with the Floating Wall Bracket.

Recessed Installation:

Recess should permit access for removal of screen if necessary. Screen may be mounted as in suspended or wall installation. Optional Ceiling Opening Trim Kit also available; see diagram on page 2 and separate instruction sheet (included with Ceiling Opening Trim Kit). *The Ceiling Opening Trim Kit is for use in an acoustic, drop ceiling only. Not recommended for drywall or hard ceilings.*

Electrical Connections

Screen operates on 110-120V, 60 Hz., 1.1 amp current draw. Duty cycle: On 28 seconds/Off 4 minutes. Junction box is located inside left endcap and cover plate is secured to endcap with two screws which may be removed with a Torx-head or small straight-blade screwdriver. Junction box contains terminal strip, per wiring diagram on reverse.

Screen is shipped with internal wiring complete and control switch(es) fully boxed. Wire connecting screen to switch(es) and switch(es) to power supply should be furnished by installer. Do NOT wire motors in parallel. Please Note: Screen must be installed in accordance with the requirements of the Local Building Codes, the Canadian Electrical Code (CEC), CAN/CSA C22.1 and the National Electric Code (NEC), NFPA 70. An appropriate disconnect device shall be provided as part of the building installation.

Ceiling Trim Kit

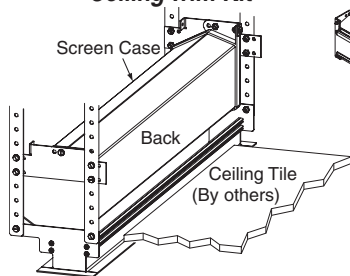

Floating Mounting Bracket

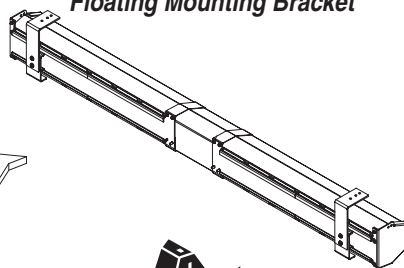

DRAPER®



All operating switches should be "Off" before power is connected. Plug-in power cord option available with built-in low voltage motor.

For Reconfiguration/Conversion of Non-detachable Power Cord to Field Wiring for Models PRE-28, PRE-29 and PRE-30 Only:

- ① Disconnect cord plug from outlet.
- ② Remove junction box cover.
- ③ Disconnect wire nuts from black, white and green wires.
- ④ Remove power cord and strain relief from screen.
- ⑤ Connect the black motor wire to "hot" supply wire.
- ⑥ Connect white motor wire to "neutral" supply wire.
- ⑦ Connect green/yellow wire to "ground" supply wire.
- ⑧ Replace junction box cover.

Operation

⚠ CAUTION—Important Instructions: Shipping support brackets must be removed from each end of dowel during initial operation, before screen is operated in UP direction. After screen is installed, lower viewing surface to access screws holding brackets to dowel. Loosen hex head screw, remove bracket and retighten screw at each end of dowel. Raise and lower viewing surface several times to confirm satisfactory operation. If viewing surface does not operate properly, turn power off and check electrical connections.

110-120V Single Station Control—3-position up-off-down switch permits operation to be stopped at any point. Factory adjusted limit switches automatically stop screen when fully down or fully up.

110-120V Multiple Station Control—Switches are similar in appearance to 110-120V Single Station Control. Screen stops when switch is released and may be restarted in either direction. Factory adjusted limit switches stop screen automatically when fully down or fully up.

24V Control—Three-button up-stop-down switch (es) stop at any point desired, operate in any sequence. Factory adjusted limit switches automatically stop screen when fully down or fully up.

Key Operated Switching—Two kinds of key-operated switches are optionally available with this unit. ① The key-operated power supply switch controls power to the screen and switches. When it is "off", the switches will not operate screen. Key may be removed from the switch in either "on" or "off" position. ② A three-position key switch permits the screen to be operated directly by key. In this case, the screen's operator must always have a key.

RS232/Ethernet—Serial communication and network communication optionally available with wall switches, RF or IR remote.

Plug & Play™—Provided with handheld IR remote control transmitter and 10' (3m) cord. No wiring necessary except to connect to RS232. Screen is equipped with a handheld remote or 3-position operating switch (see below). Three positions (up-off-down) permit operation to be stopped at any point. Factory adjusted limit switches automatically stop screen when fully down or fully up.

Limit Adjustments (Standard/Quiet Motors)

Please Note: Screen limits are factory set for optimum performance of the screen. Any adjustment of these limits could void the warranty. Please check with Draper prior to resetting screen limits.

⚠ CAUTION: Always be prepared to shut screen off manually when new adjustment is being tested. Screen may be severely damaged if viewing surface is allowed to run too far up or too far down.

⚠ CAUTION: Be sure all switches are in "off" position before adjusting limit switches.

The motor limit screws are normally located on the audience left of screen roller, and the viewing surface rolls off the back of the roller. If the viewing surface is coming off the front of the roller (motor on left), or the motor is on the audience right of the screen roller (with viewing surface rolling off the back), reverse the below instructions.

"DOWN" LIMIT ADJUSTMENT

To Reduce Screen Drop

- ① Raise screen surface about 1' above desired setting and turn off.
- ② Turn the DOWN limit screw (I) clockwise (three screw turns = ½ roller revolution).
- ③ Test by running screen down and repeat steps 1 and 2 until desired position is reached.

To Increase Screen Drop

- ① Run screen to the down limit.
- ② With the down switch on, turn the DOWN limit screw (I) counterclockwise (three turns of screw equals ½ roller revolution) to increase drop.
- ③ Test by running screen up about 1' and back down to new down limit.
- ④ Repeat steps 2 and 3 until desired position is reached.

"UP" LIMIT ADJUSTMENT

Screen is Running Too Far Up

- ① Lower screen surface about 1' below desired setting and turn off.
- ② Turn the UP limit screw (II) clockwise (three screw turns = ½ roller revolution).
- ③ Test by running screen up.
- ④ Repeat steps 1 through 3 until desired position is reached.

Continued on page 2

Screen Needs to Run Up More

- Run screen down about 1' and turn off.
 - With the up switch on, turn the UP limit screw (II) counterclockwise (three turns of screw equals 1/2 roller revolution).
 - Repeat steps 1 and 2 until desired position is reached.
- CAUTION: Do NOT allow the dowel to wrap up over the roller when the screen is running up! This could damage the screen.**

Limit Adjustments (Built-in Low Voltage Motors)

(Height adjustments are made from wall switch)

Please Note: Screen limits are factory set for optimum performance of the screen. Any adjustment of these limits could void the warranty. Please check with Draper prior to resetting screen limits.

CAUTION: Always be prepared to shut screen off manually when new adjustment is being tested. Screen may be severely damaged if viewing surface is allowed to run too far up or too far down.

CAUTION: Be sure all switches are in "off" position before adjusting limit switches.

- Connect the switch to the motor via the terminal blocks, or via the modular port using four conductor modular cable. When using modular cable, the cable connectors MUST NOT be crimped in reverse, as with standard telephone cable.
- Set the slide switch to the lower position. Press and hold the DOWN button on the switch to move the viewing surface to the desired lower limit. If the screen moves in the opposite direction, release the DOWN button and press and hold down the STOP button for four seconds. This will reverse the operation of the UP and DOWN switches.
- Move slider switch into center position. Wait a couple of seconds.

POSITION	FUNCTION
DOWN	Set LOWER limit
UP	Set UPPER limit
CENTER	Normal Operation

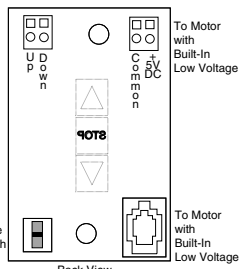

Please Note: If you move the slider switch from down to up in one motion it sets the two limits in the same position.

- Set the slide switch to the higher position. Move the viewing surface to the desired upper limit by pressing and holding the UP button on the wall switch.
- Return the slide switch to the center position to return to normal operation.
- To set the viewing surface to an alternate format position, move the viewing surface to the desired position and press the STOP button. Press and hold the STOP button for at least three seconds to record the position.

Please Note: Pressing and releasing the UP button on the switch will move the screen to its upper limit. Pressing and releasing the DOWN button will move the screen to its lower limit.

While the motor is in motion, pressing the STOP button for less than two seconds will stop the viewing surface at its present position.

Once the motor is stopped, pressing the STOP button will move the viewing surface to its alternate format position.

Pressing and holding the STOP button, when the motor is at rest or in motion, for at least three seconds will record a new alternate format position.

Tab-Tension Adjustment Procedure for Premier

- Determine which side requires adjustment.
- Secure dowel with one hand.

CAUTION: Do not touch or bend surface.

- Using Phillips-head screwdriver, depress spring-loaded adjustment screw (see drawing) and slowly turn clockwise to tighten tension, or counterclockwise to loosen tension. The screw adjusts in 1/4 turn increments. Adjust only **one increment** (1/4 turn).

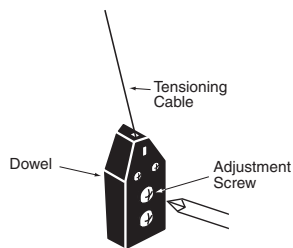

- If problem is not corrected, leave screen in position for 24 hours to allow surface material to stretch into position.
- If problem still is not corrected, repeat steps 2 and 3.

Case Dimensions

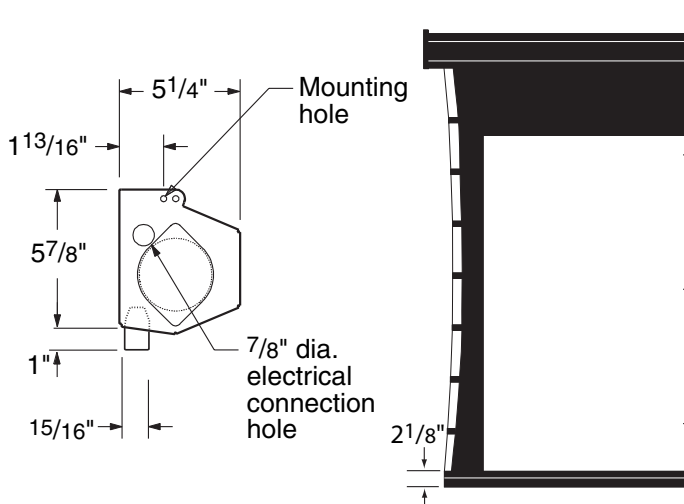

Types of Installation

Optional Ceiling Opening Trim Kit (Dims-Side View)

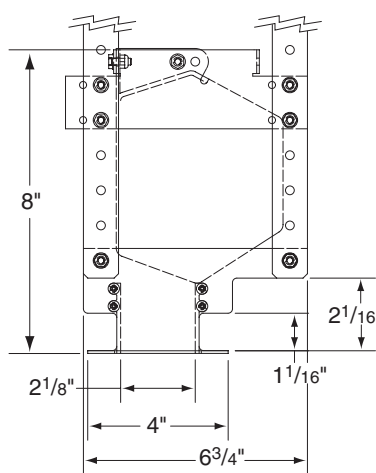

Wall

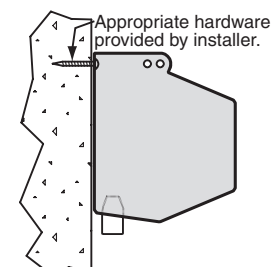

Suspended

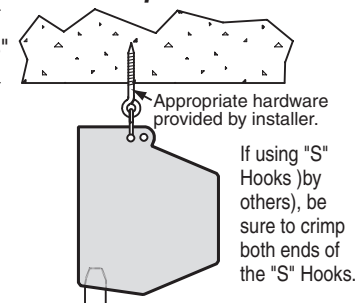

Built-in Low Voltage Motor: Switch-to-Motor—Dry Contacts or Data Cable connection

Please Note: 5V DC must be connected to be able to set limits using the wall switch.

Back of wall switch.

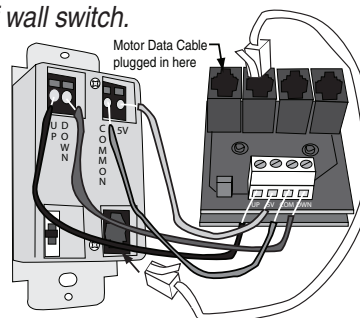

Please Note: This Splitter/Jack is located inside the motor-end endcap of your screen. To access, remove access panel from endcap.

Data Cables to switches or to additional motors can be plugged into any of the three open jacks.

Please Note: Although both Dry Contact and Data Cable connections are shown, you should only use one connection type per motor.

(Wiring Diagrams Standard and Quiet Motors)

Please Note: Do not wire motors in parallel.

Single Station Control

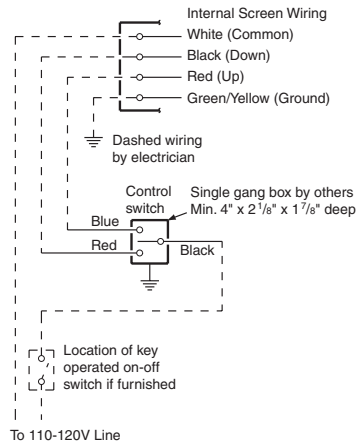

Multiple Station Control

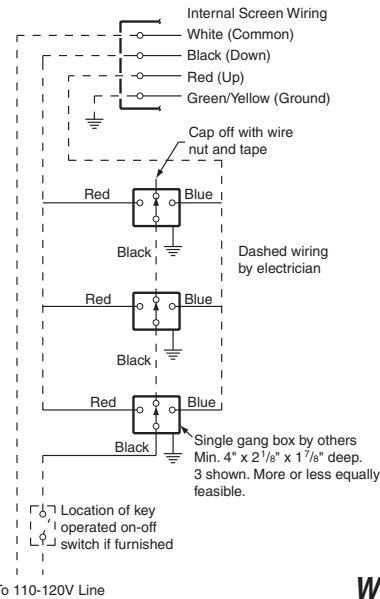

Wiring Diagrams—Plug & Play 110-120V Motor with Built-in Low Voltage Controller

Single Low Voltage Control

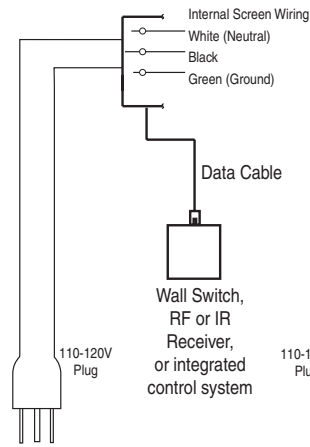

Multiple Low Voltage Controls

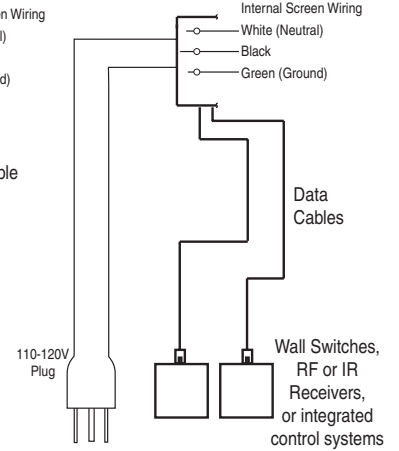

External Low Voltage and Remote Control

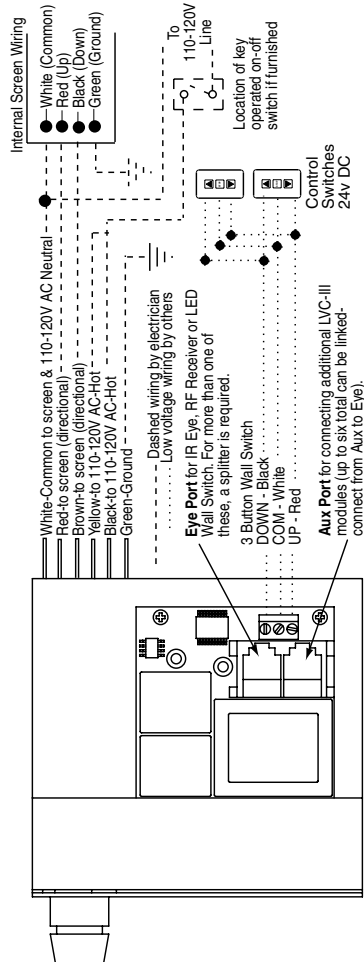

Wiring Diagrams—110-120V Motor and Quiet Motor with Built-in Low Voltage Controller

Single Low Voltage Control

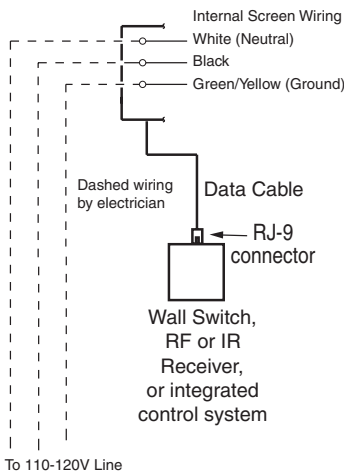

Multiple Low Voltage Controls

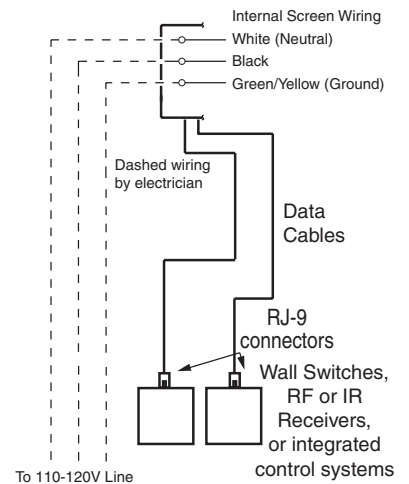

External Two-Way Serial Communication (RS232) with MC1

