

Installation Instructions

Attaching Premier/Targa—Small Case to TorkStar Utility Line Set by Draper

⚠ Caution

- ① Hoist screen for attachment using the eyebolts in the hanging brackets on each end of the screen. **DO NOT** lift case by the center, *picking the case up at other points will damage the case.*
- ② Screen must be installed so it is hanging level. Use a level to doublecheck.
- ③ For wiring diagram (if required), see the instruction sheet for this model of screen.
- ④ Make sure all connections are secure before hoisting the screen.
- ⑤ **Key switch to be in full view of unit during operation.**
- ⑥ If projection screen attachment points do not match up with the drop cables from the spools, an intermediate batten can be used. Attach the batten to the TorkStar drop cables, then attach the projection screen to the batten.
- ⑦ These instructions may be used only for installing the Draper Premier or Targa small case screen. This kit is not designed for use with any other projection screen manufactured by Draper or with any screen from another manufacturer.
- ⑧ If using a Projection Screen Batten (see page 2) batten **MUST** be 2.5" O.D. by minimum of 13 gauge.

These instructions are meant as a guide only. They do not bind Draper, Inc. in any way and do not imply any responsibility of Draper, Inc. for improper installation or faulty workmanship at the job site.

Electrical Cable Attachment Detail

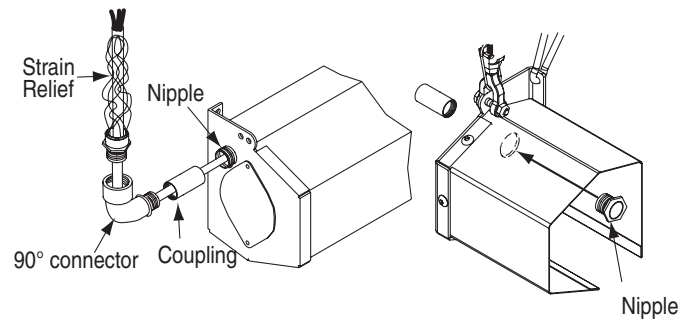

Direct Mounting to Premier/Targa—Small Screen Case

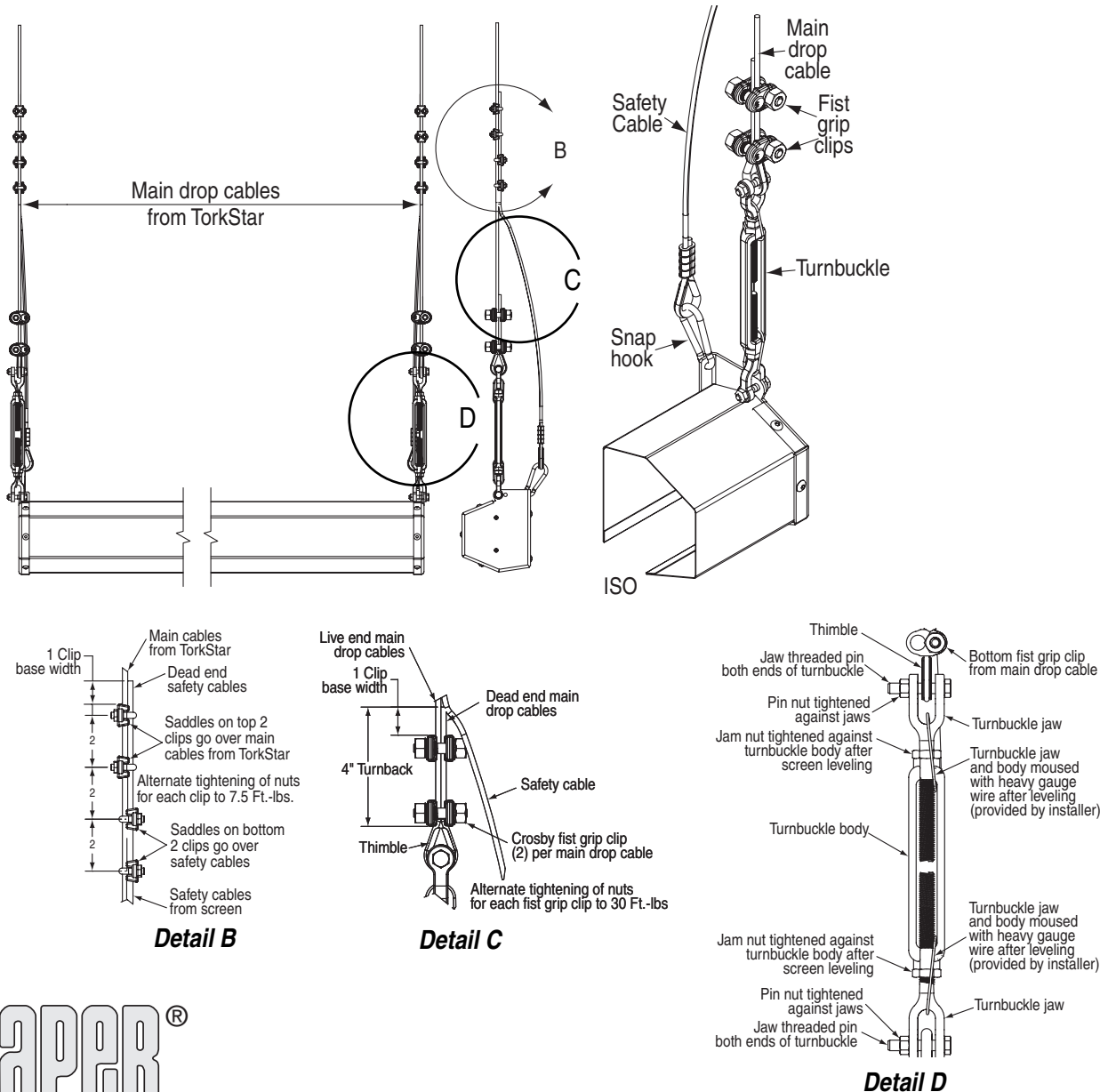

DRAPER®

Mounting to Batten then to Premier/Targa—Small Screen Case

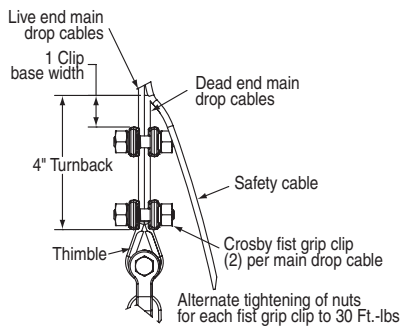
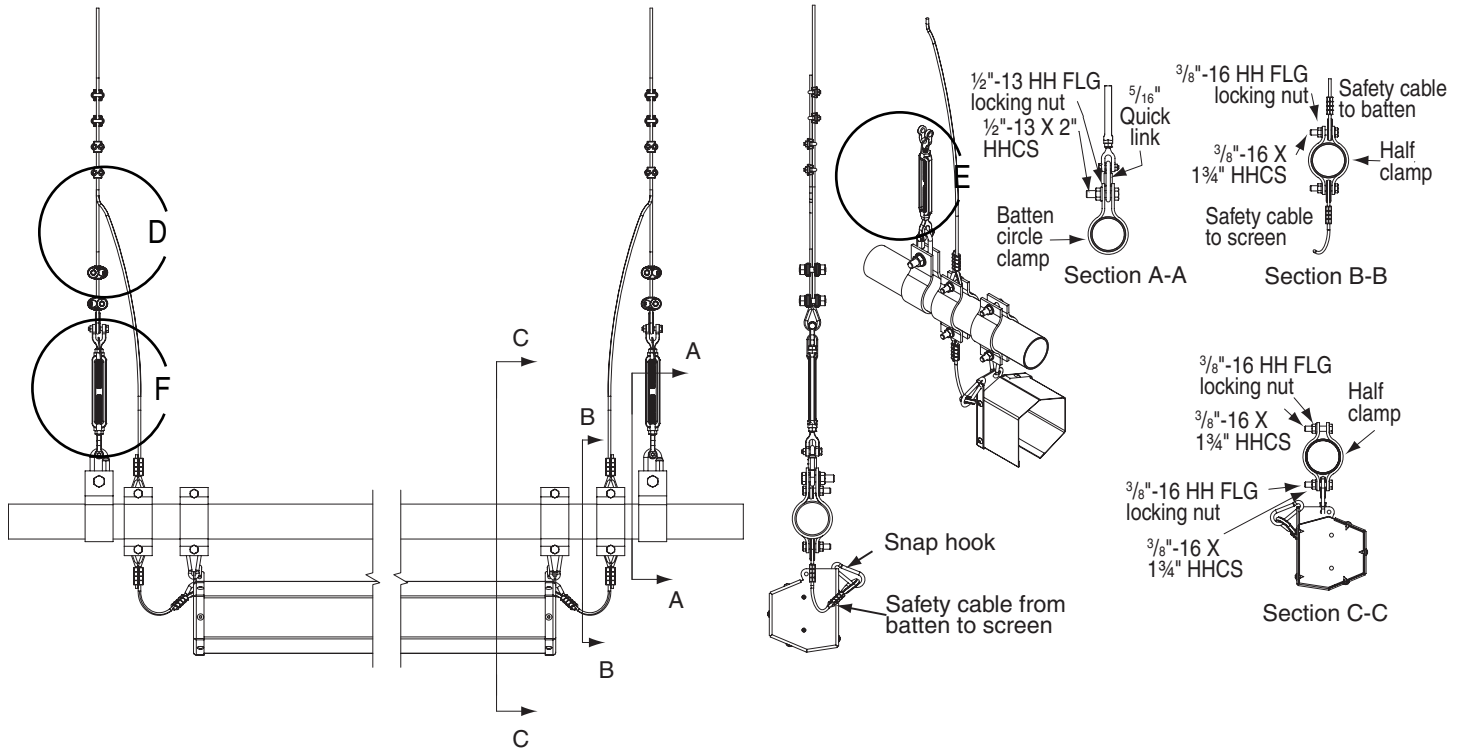

Detail D
(See "preparing cable terminations", pg. 2 of TorkStar TS1000 or TS1400 instructions)

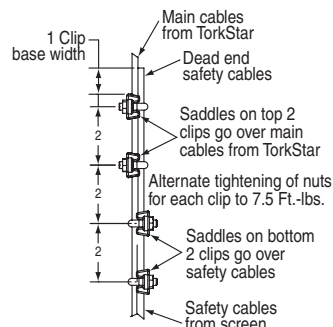

Detail E

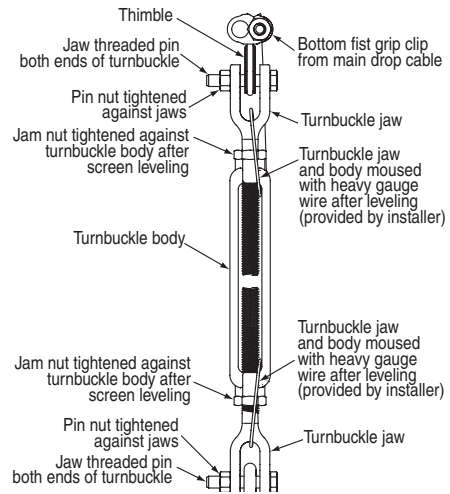

Detail F

Electrical Cable Attachment Detail

